

the **HAMWORTHY**

BRAZED PLATE HEAT EXCHANGER

150kW

**Perfect for refurb
and retrofit
situations**

Compact design

Low maintenance
and self-cleaning

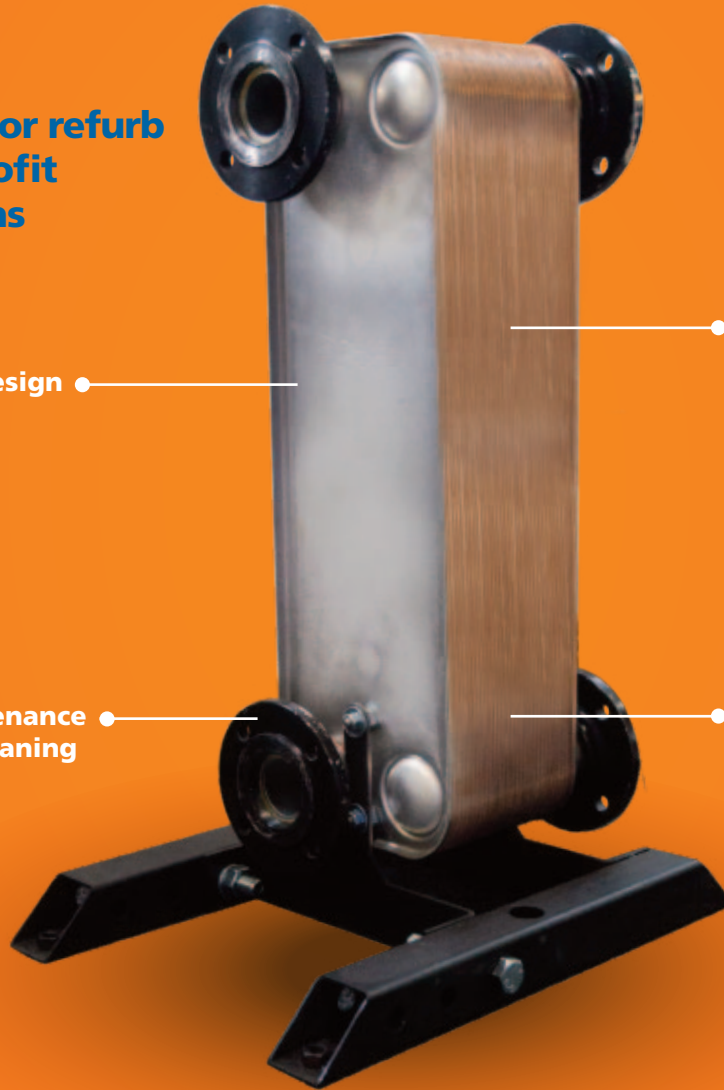

Separates system
water from the boiler

Used with Hamworthy
Heating Cascade kits



SCAN
ME

ASK
advice. specification. knowledge.

Hamworthy

Brazed Plate Heat Exchanger – 150kW



150kW is the nominal capacity of the plate heat exchanger applying the operating conditions shown below. Please contact Hamworthy Heating to confirm the expected performance if the operating conditions differ from those shown.

DN50

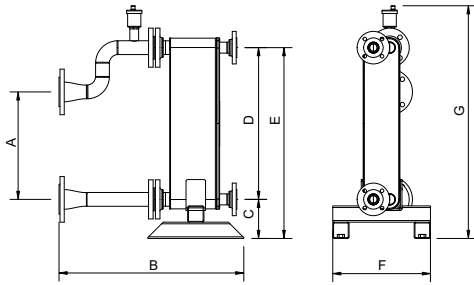

DN80

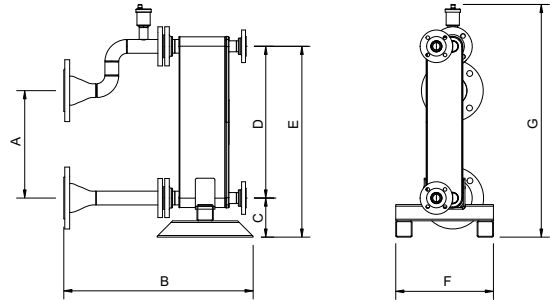

Installed dimensions

Dimension	A	B	C	D	E	F	G	Installed weight (including PHE, spools and support)
DN50	330	566	120	466	586	300	720	DN50 Kit = 27.5kg
DN80	330	580	120	466	586	300	720	DN80 kit = 30kg

	UNITS	HOT SIDE	COLD SIDE
Mass flow rate	kg/s	1.79	1.79
Inlet temperature	°C	80	50
Outlet temperature	°C	60	70
Pressure drop	kPa	12.0	18.0
Heat exchanged	kW	150	
Heat transfer area	m ²	3.4	
Flow configuration	Countercurrent		
Number of plates / thickness	60 / 0.3 mm		
Number of passes		1	1
Pressure vessel code	PED		
Design pressure at 90.00 Celsius	Bar	40	40
Design pressure at 225.0 Celsius	Bar	32	32
Design temperature	°C	-196.0 / 225.0	
Overall length x width x height	mm	??? x ??? x ???	
Volume	L	3.1	3.0

Standard materials

Cover plates	Stainless steel
Connections	Stainless steel
Plates	Stainless steel
Brazing	Copper

PLEASE NOTE:
The plate heat exchangers are to be used for system separation only.
They must not be used for the direct production of domestic hot water.

They should not be used for direct heating of swimming pool water where the chlorinated pool water would pass directly through the plate heat exchanger.

Connections

FRAME & HEADER

Stratton mk3	DN50	DN80	DN100
	✓	✓	
System			
DN25			
Flanged			
PN6			