

# Let's get together.

**The Dresser**

THUMA

Take care while assembling The Dresser. For safety, carefully follow assembly instructions. Keep drawers horizontal while stacking, hold pieces in place and check all four sides to ensure they are properly nested and fully secured. Avoid balancing and do not bend over around unsecured pieces. Keep out of the way of children.

# Configurations

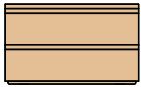

2x1



3x1



4x1



5x1

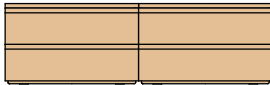

2x2

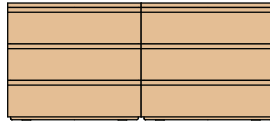

3x2



4x2



3x3

Do not stack more than 5 Dressers vertically.

# The Pieces

## Top Tray

- x1 for 2/3/4/5 x 1
- x2 for 2/3/4 x 2
- x3 for 3x3

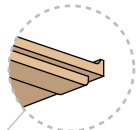

Ski

## Drawer

- x2 for 2x1
- x3 for 3x1
- x4 for 4x1, 2x2
- x5 for 5x1
- x6 for 3x2
- x8 for 4x2
- x9 for 3x3

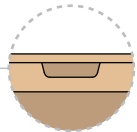

Lift Handle

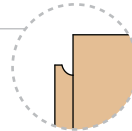

Dresser Handle

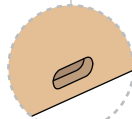

Opening

## Screw



- x1 for 2x1
- x2 for 3x1, 2x2
- x3 for 4x1
- x4 for 5x1, 3x2
- x6 for 4x2, 3x3

# Step 1

Select any drawer by the lift handles and place it where you'd like The Dresser to stand.

This is the bottom drawer.

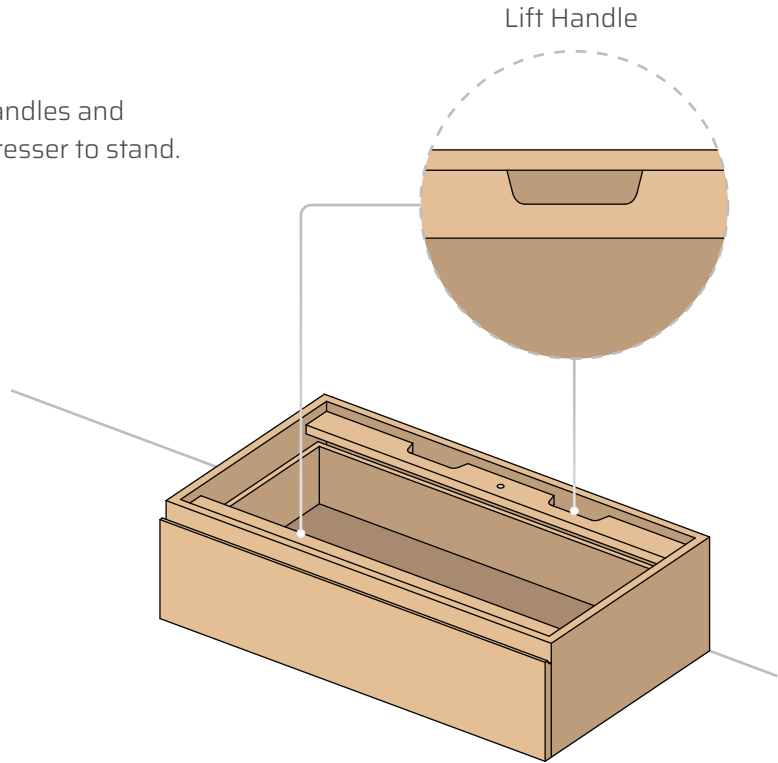

# Step 2

A-B. Stack the second drawer on top of the bottom one.

Check all four sides to ensure drawers are properly nested.

View from front

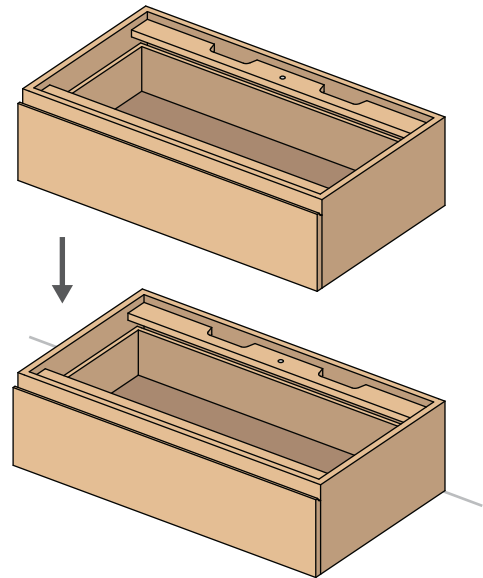
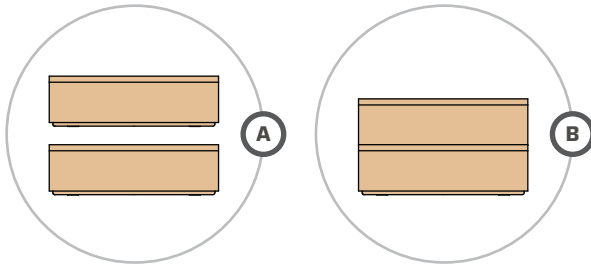

# Step 3

A. Open the top drawer using its handle.

B. Use a screw to secure the top drawer to the bottom one. Tighten by hand.

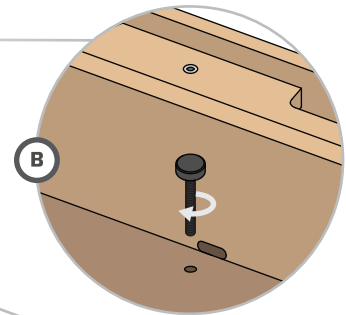
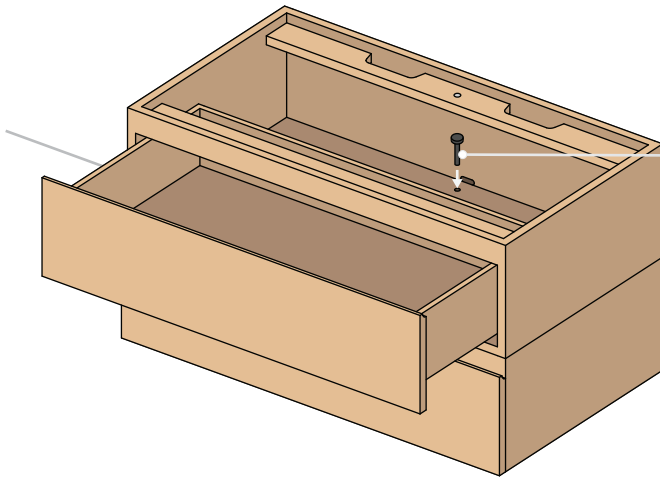
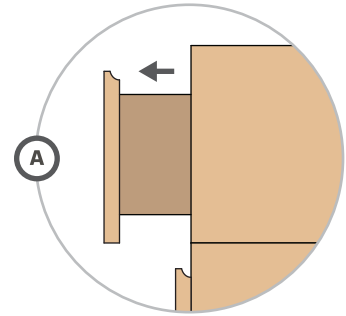

# Step 4

A. Repeat stacking and securing the drawers until the desired configuration is reached.

B. If you'd like to stack the drawers next to each other for a horizontal configuration, ensure there is no gap between the drawers when placed side by side.

Do not stack more than 5 Dressers vertically.





# Anti-Tip Feature

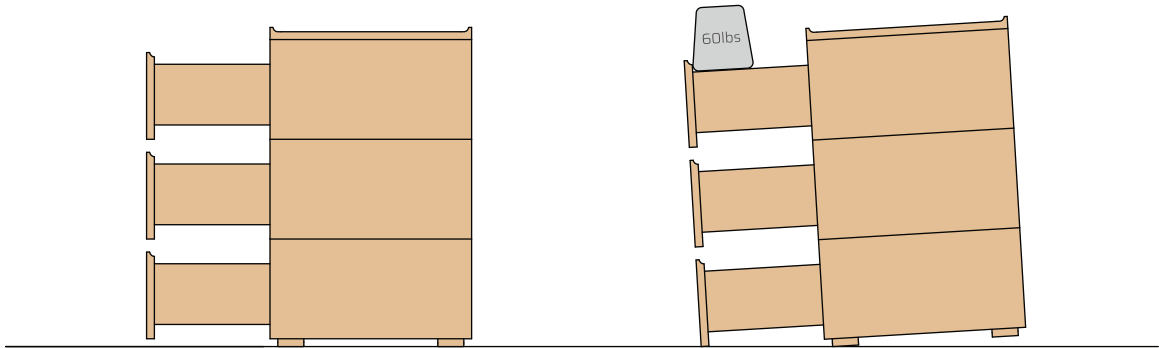

Our Dresser is specifically designed for the bottom drawer to act as an anti-tip feature. When open, it obstructs the Dresser from tipping over.

# Anti-Tipping Hardware

To prevent injury or damage from unexpected tipping of furniture,  
The Dresser should be secured to the wall using anti-tipping hardware.

## Cable

x1 for 2/3/4/5 x 1  
x2 for 2/3/4 x 2  
x3 for 3x3

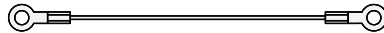

## Wall Screw

x1 for 2/3/4/5 x 1  
x2 for 2/3/4 x 2  
x3 for 3x3



## Wall Anchor

x1 for 2/3/4/5 x 1  
x2 for 2/3/4 x 2  
x3 for 3x3



## Step 5

Pull out top drawer and draw a mark on the wall through the opening, then close the drawer.

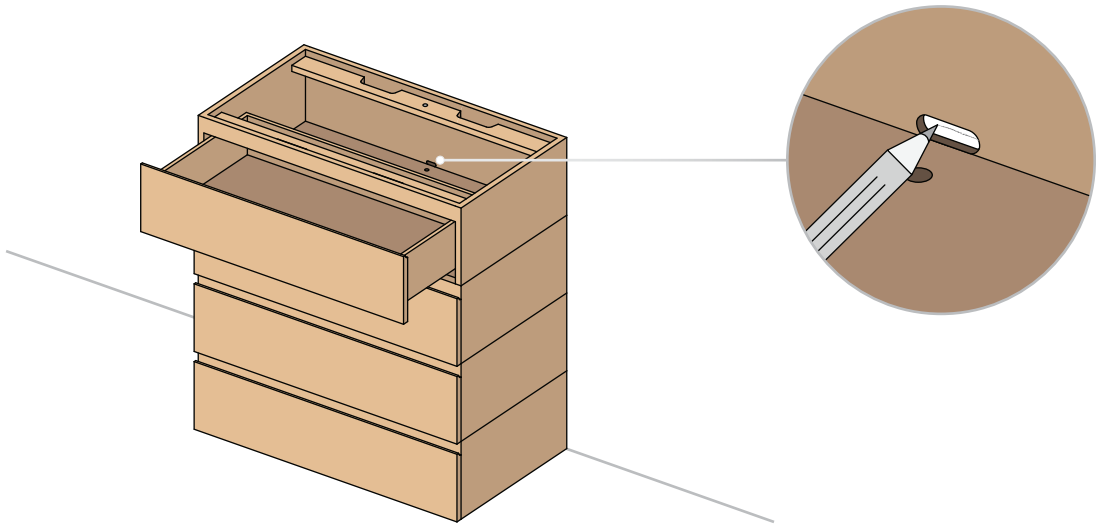

Repeat this step with the second or third stack, one for each stack.

# Step 6

Rotate dresser at a 90° angle.

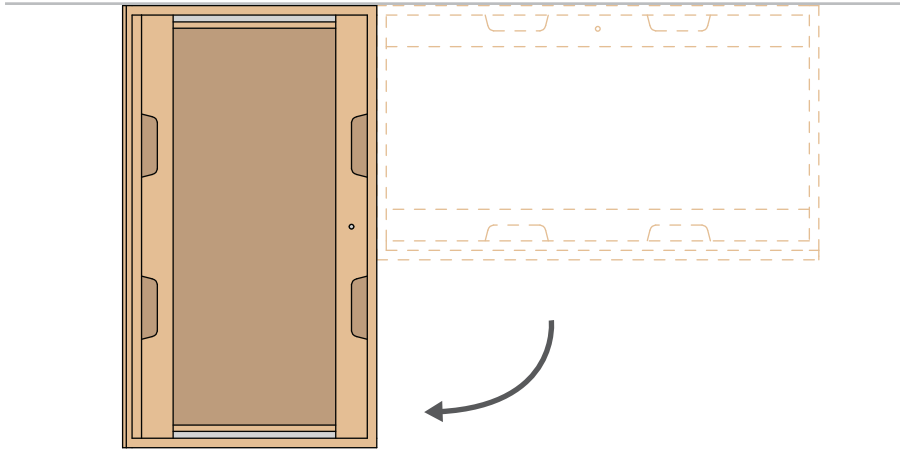

# Step 7

A. Drill hole in wall with a 9/32" drill bit.

B. Hammer the anchor in the hole.

C-D. Secure cable to wall with wall screw.

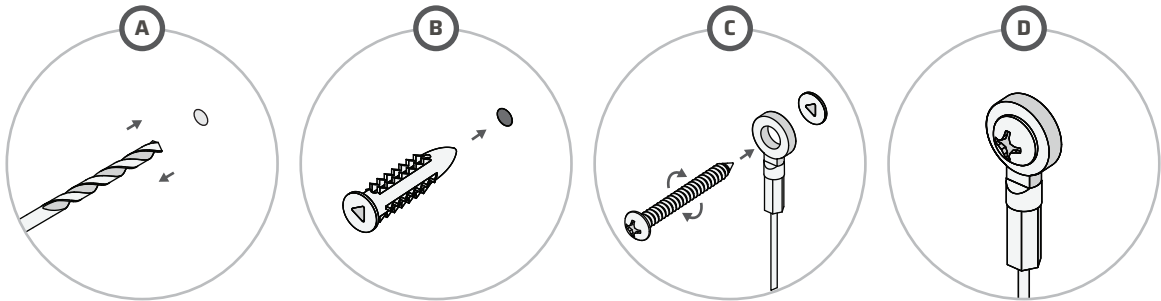

## Step 8

Rotate The Dresser towards the wall,  
leaving a bit of space between it and the wall.

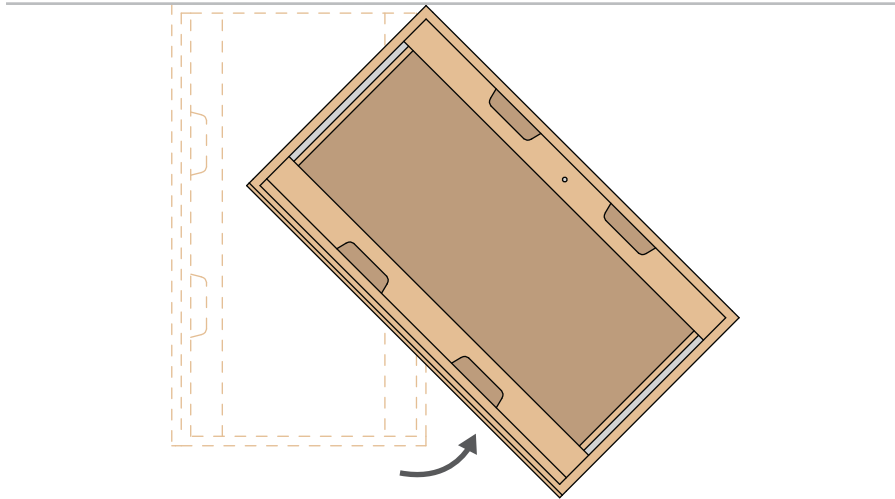

## Step 9

Pass the cable through the opening on the back of The Dresser.

This is the same opening used to mark the wall.

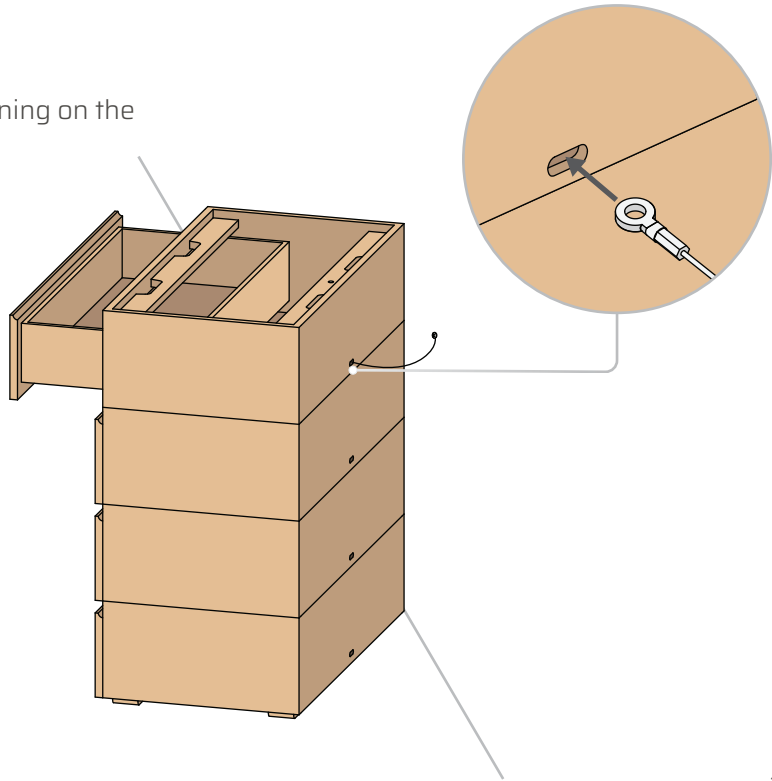

# Step 10

Use the screw to attach the cable to The Dresser.  
Tighten by hand.

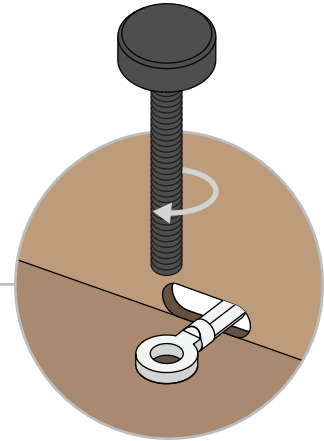
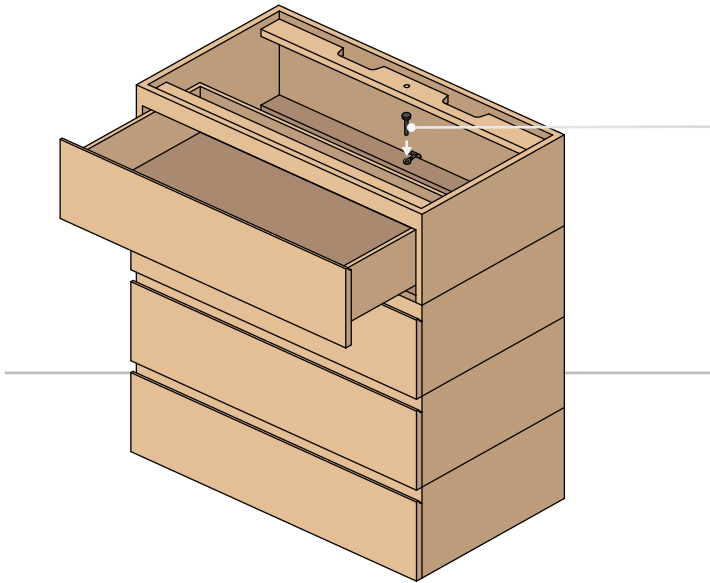



# Step 11

Push The Dresser against the wall.

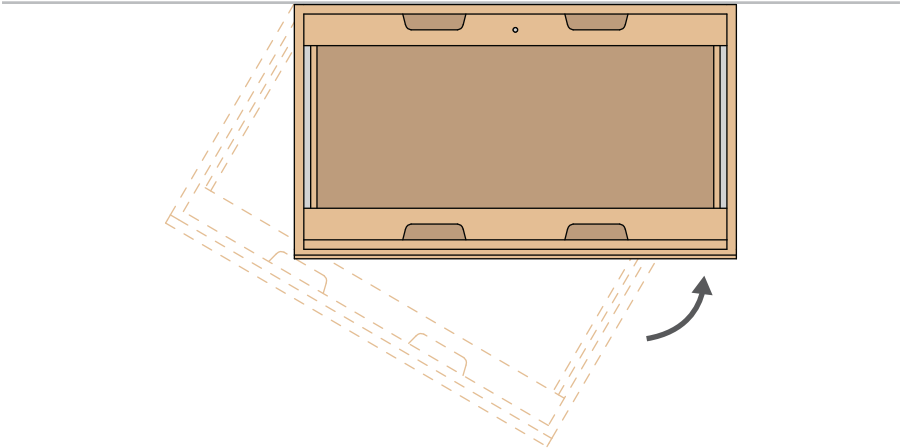

# Step 12

A-C. Slide the top tray from the front with skis facing down on the last topmost drawer.

Check all four sides to ensure top tray is properly nested.

And you're all set.

Repeat this step with the second or third stack if needed.

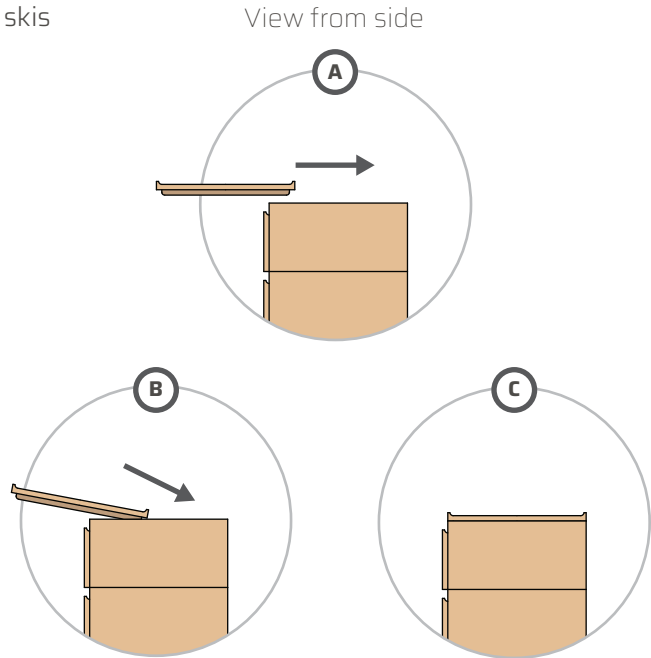

# Enjoy.

Light a candle, play some jams, pour yourself a refreshment.

Share your favorite Bed Times with us on Instagram @thuma.co for a chance to be featured.

thuma.co | @thuma.co | #thuma #forBedTime

---

For help & more to love, scan the QR code below.

