

FUNDAMENTALS

06-4431
BATHROOM FAUCET

Taymor



| POLISHED CHROME | CASE QTY. |
|-----------------|-----------|
| 06-4431 | 6 |

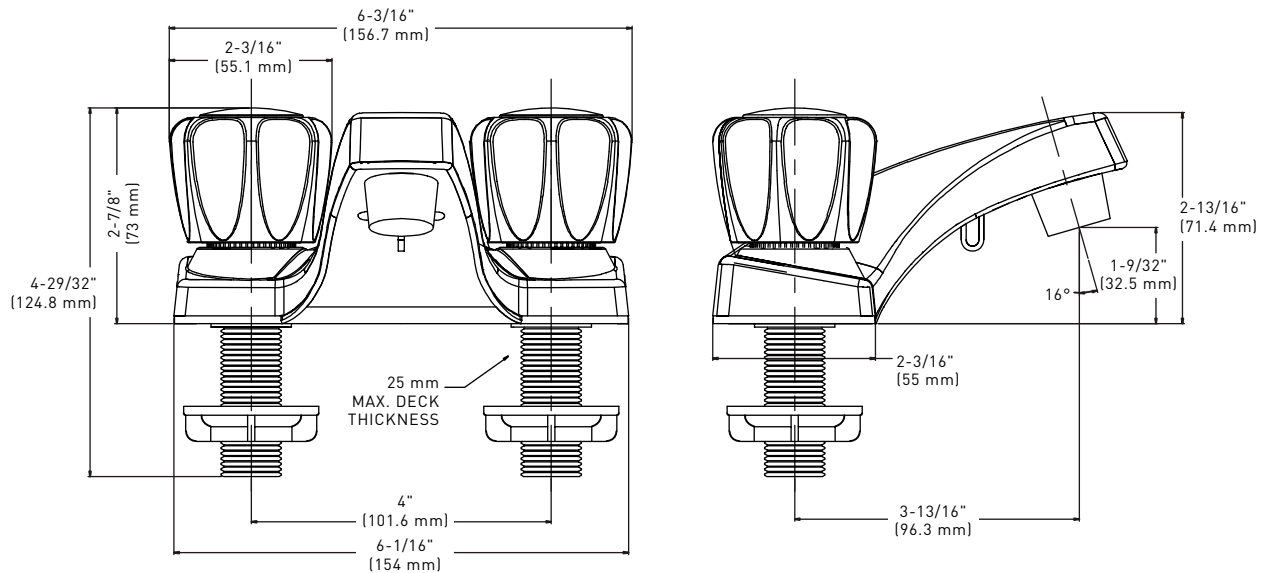

CRITICAL DIMENSIONS NOT TO SCALE

FEATURES

- TWO ACRYLIC HANDLES
- 4" CENTER-SET MOUNT
- WASHERLESS CARTRIDGE
- FACTORY PRESSURE TESTED

CONSTRUCTION

- RESIN CONSTRUCTION WITH POLISHED CHROME FINISH

MOUNTING

- DESIGNED TO INSTALL THROUGH 2 HOLES, 7/8" (23mm) MIN. DIA. WITH 4" (102mm) CENTERS ON DECKS UP TO 1" (25mm)

INLET

- 1/2"-14 NPSM THREADED MALE INLET SHANKS

OPERATION

- QUARTER-TURN ACRYLIC KNOB STYLE HANDLES
- OPERATES WITH LESS THAN 5 LBS. OF FORCE

WATER-CONTROL MECHANISM

- CARTRIDGE
- ROTATING CYLINDER TYPE WITH STAINLESS STEEL PLATE AND NON-METALLIC SEATS

FLOW

- AERATOR LIMITS MAXIMUM FLOW RATE TO 1.5 GPM MAX. (5.7 L/MIN.) @ 60 PSI

CODES/STANDARDS APPLICABLE

- cUPC
- ASME A112.18.1/ CSA B125.1
- ANSI/NSF 61/9
- LOW LEAD COMPLIANT

GUARANTEE

- 1 YEAR GUARANTEE AGAINST DEFECTS IN MATERIAL AND WORKMANSHIP TO ORIGINAL CONSUMER PURCHASER

