



BALL KNOB TRIM



**10 YEAR MECHANICAL WARRANTY**

GRADE  
**1**

**ANSI GRADE 1**



**FULL KEYING SERVICES AVAILABLE**

6-pin SC4 keyway, packaged keyed different



**FIRE RATING AVAILABLE**

Works with c-UL 1.5 / 3-hour fire rating standards depending on exit device selection.

### SPECIFICATIONS

- NEW ENHANCEMENTS** MEETS OR EXCEEDS BHMA/ANSI GRADE 1 ULTRA-HEAVY DUTY ACTUATING MECHANISM
- COMPATIBILITY** ALL 8500 & 9700 SERIES PUSH PAD EXIT DEVICES)
- FUNCTIONS** ENTRY\*, STOREROOM
- CYLINDER** RIM CYLINDER WITH 6 PIN SCHLAGE 'C' KEYWAY FOR STOREROOM FUNCTION MORTISE CYLINDER (1-1/8" DEPTH) WITH 6 PIN SCHLAGE 'C' KEYWAY FOR ENTRY FUNCTION

\*ENTRY FUNCTION ALSO SERVES AS CLASSROOM FUNCTION

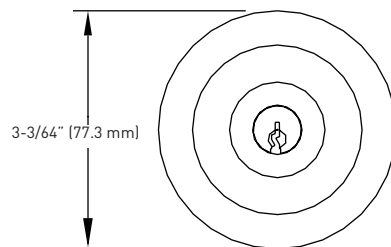
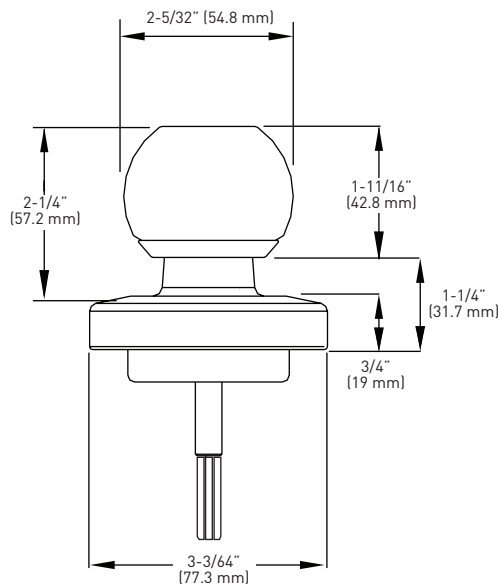

#### BALL KNOB TRIMS

	32D SATIN STAINLESS STEEL	CASE QTY.
ENTRY FUNCTION* - SCHLAGE "C" KEYWAY	17-ENBKAL	6
STOREROOM FUNCTION - TRIM MOUNTING PLATE INCLUDED (17-PPMTMP)	17-SRBKAL	6