

INSTALLATION INSTRUCTIONS

17-F8536VAL /17-F8536VSS
8500VF SERIES
FIRE RATED PUSH PAD VERTICAL ROD EXIT DEVICE
 LHR DOOR SHOWN (RHR DOOR OPPOSITE)

Taymor

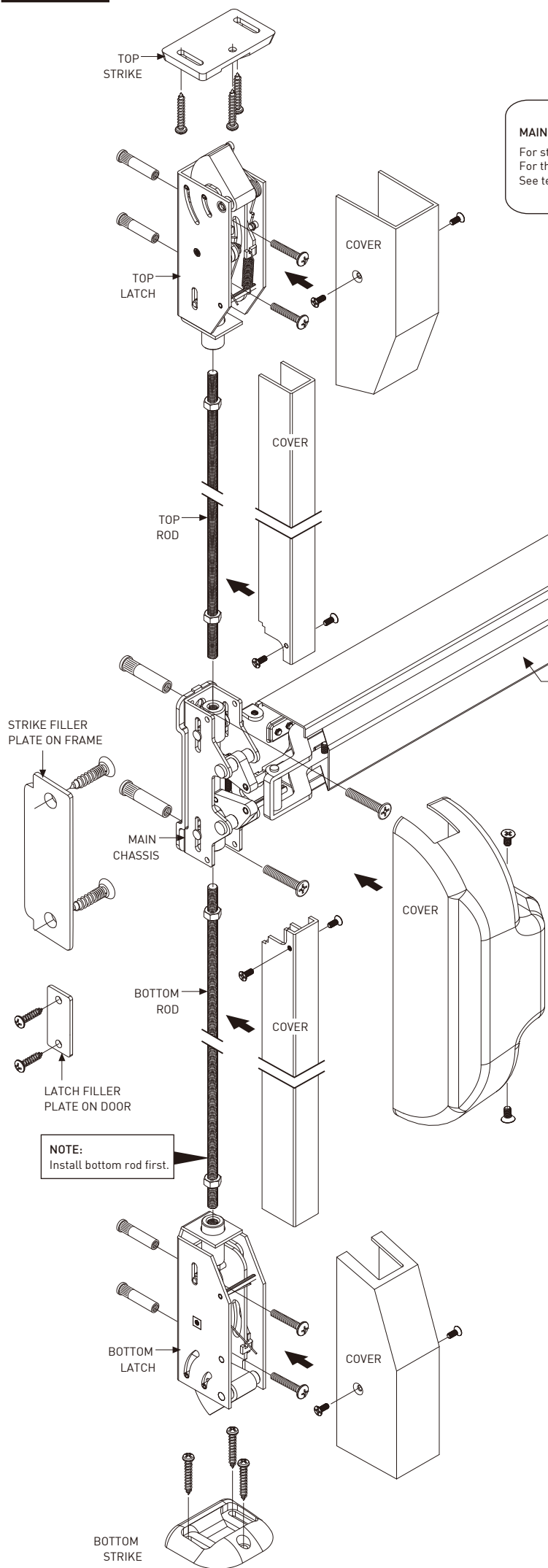

MAIN CHASSIS & TOP AND BOTTOM LATCHES MOUNTING SCREWS

For steel prepared doors, drill / tap and use supplied machine screws.
 For thin gauge metal, non-prepared doors or for labelled wood doors use thru bolts.
 See template for details on mounting screws.



CUT DEVICE IF NECESSARY
 Device length (A) must be at least 2-3/16" (56mm) shorter than (B)

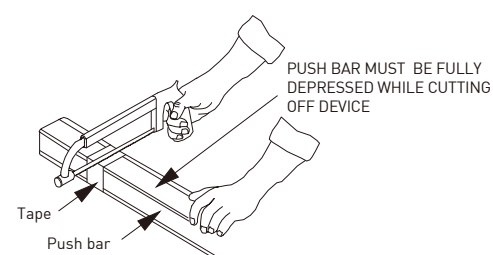
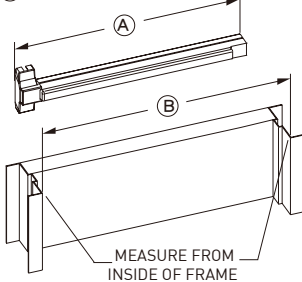

When a different rod length is needed use instructions below to cut rod.

