

SPECIFICATIONS

- NEW ENHANCEMENTS** ULTRA-HEAVY DUTY ACTUATING MECHANISM
- COMPATIBILITY** 8500 & 9700 SERIES PUSH PAD EXIT DEVICE
- FUNCTION** NON-HANDED OUTSIDE THUMBPIECE TRIMS
- MATERIAL** HEAVY DUTY CAST ZINC ALLOY FOR HANDLE AND PLATE
- FINISHES** ALUMINUM (C28)
- MOUNTING PEG** 5-1/2" C/C DISTANCE
- ESCUTCHEON PLATE SIZE** 3" x 12-5/16" x 3/32" [76 mm x 312.5 mm x 2.5 mm]
- PROJECTION** 25/32" (45mm) MAXIMUM
- CYLINDER** RIM CYLINDER WITH 6 PIN SCHLAGE 'C' KEYWAY FOR STOREROOM FUNCTION
MORTISE CYLINDER (1-1/8" DEPTH) WITH 6 PIN SCHLAGE 'C' KEYWAY FOR ENTRY FUNCTION
- TRIMS/FUNCTIONS** ENTRY*, STOREROOM, PASSAGE AND DUMMY



17-ENTPAL
ENTRY



17-STTPAL
STOREROOM



17-PSTPAL
PASSAGE



17-DUPAL
DUMMY

- A = 12-5/16" (312.5mm)
- B = 3" (76mm)
- C = 1-7/8" (47.5mm)
- D = 5-1/2" (139.5mm)

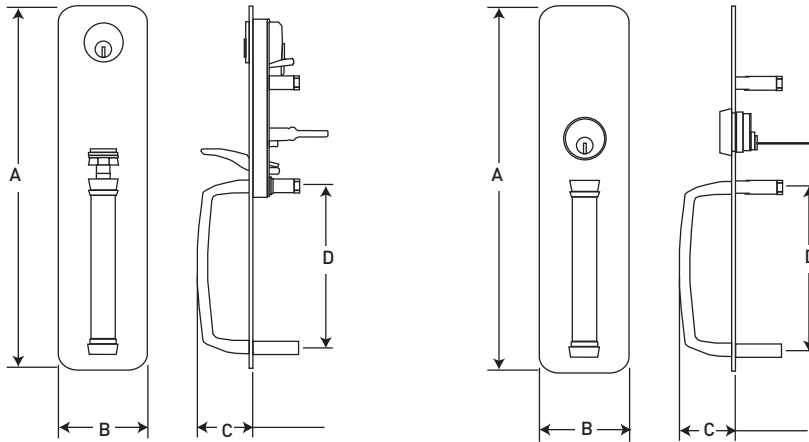

17-ENTPAL
ENTRY

17-STTPAL
STOREROOM

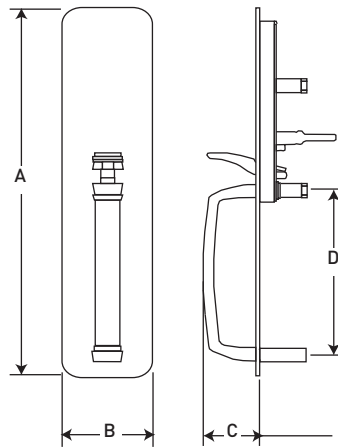

17-PSTPAL
PASSAGE

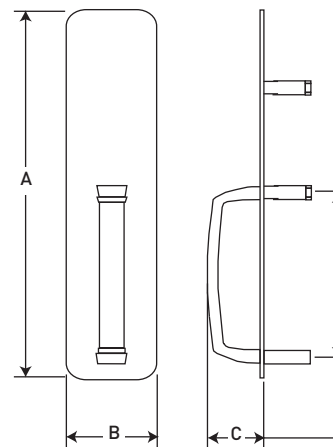

17-DUPAL
DUMMY



**5 YEAR
MECHANICAL WARRANTY**



**FULL KEYING SERVICES
AVAILABLE**

6-pin SC4 keyway, packaged
keyed different

THUMBPIECE OUTSIDE TRIMS

	C28 ALUMINUM	CASE QTY.
ENTRY FUNCTION* - SCHLAGE 'C' KEYWAY	17-ENTPAL	10
STOREROOM FUNCTION	17-STTPAL	10
PASSAGE FUNCTION	17-PSTPAL	10
DUMMY FUNCTION	17-DUPAL	10