

HFC – High Feed Cutter

The New Generation of the
High Feed Milling Cutter Series

www.lmt-tools.com

LMT•TOOLS
BELIN
FETTE
KIENINGER
ONSRUD

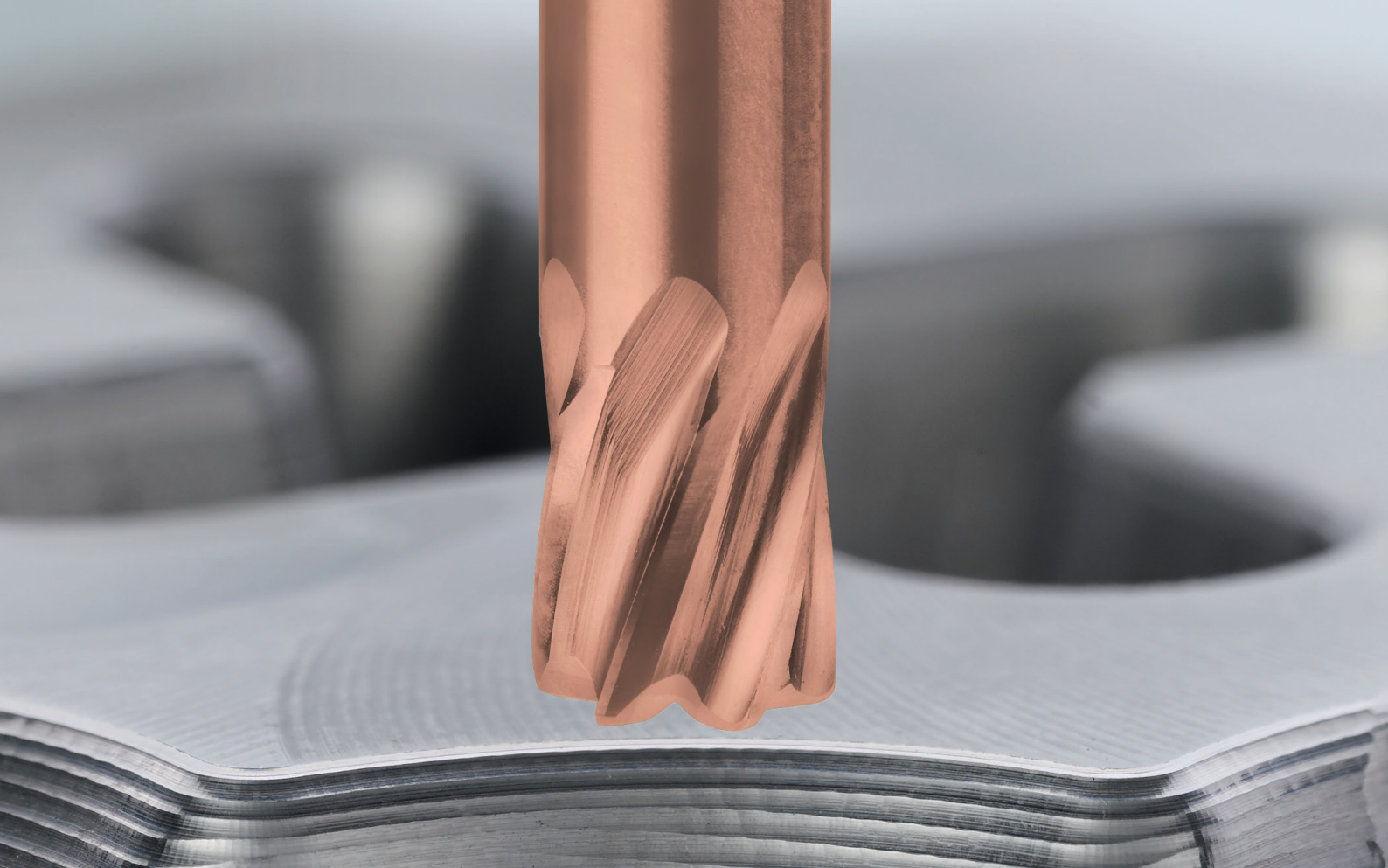

Our Complete Program For High Feed Milling

Our latest HFC (High Feed Cutter) product range is the perfect tool for anyone looking for maximum productivity. Every detail of this product family is optimized for high feed usage from the geometry and number of teeth to their substrate as well as the advanced coating. As a tailor-made solution for high feed machining, the HFC family enables optimal and efficient machining in any material.

With our HFC P tools you can achieve the best results in steel and cast iron. Our HFC M tools are perfect for use in austenitic steels and superalloys. For the hardest applications use our HFC H which can machine hardened steels of up to 65 HRC. The HFC U is the universal solution and is designed like a classic high feed mill with two cutting edges in ISO groups P, M and K.

Versatile Machining With Maximum Productivity

Whether you are in die and mold making, general machining, aerospace or other industries – wherever high feed milling is used, our HFC tools are the best choice for you. Experience the future of high feed milling with our new HFC family and increase your efficiency and productivity to a new level!

Your advantages:

- Longer tool life thanks to the latest substrates and coatings
- Increased tool life when machining stainless steels when using tools with internal cooling
- Extensive range of different lengths for use in a wide variety of applications
- High number of cutting edges enables high feed rates for high productivity

Cylindrical shank

Neck relief

Latest generation coating

Extended sheath cutting edge, regrindable





Micro cutting-edge preparation

S-shape design

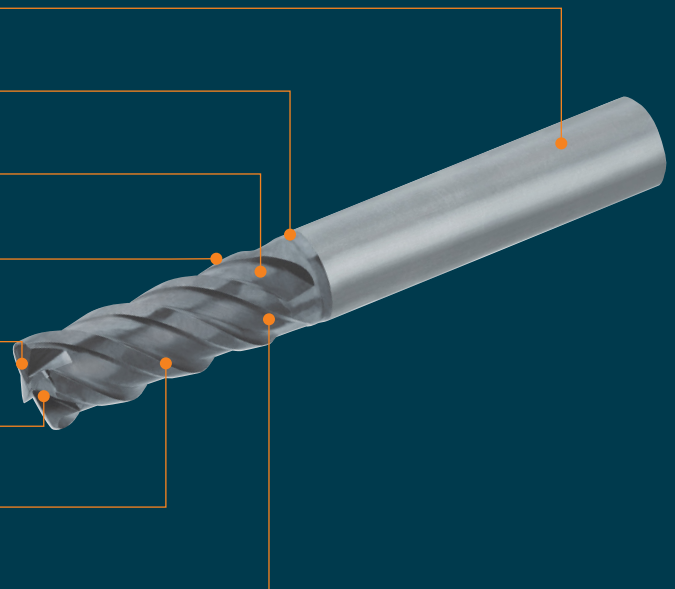
Grade trimmed to respective focus applications

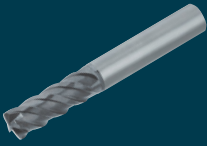
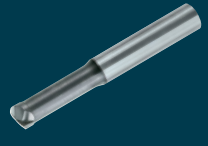
Geometry specially adapted to the application



HFC P	HFC M	HFC H	HFC U	
				
For steel and cast iron	For austenitic steels and superalloys	For hardened steels up to 65 HRC	Universal solution for ISO groups P, M and K	
P Second choice: K	M Second choice: S	H Second choice: P K	P M K Second choice: H	
				
High feed milling	Copy milling	Groove milling	Pocket milling	Circular milling

HFC01 Rougher P

High feed end mills for high alloy steels

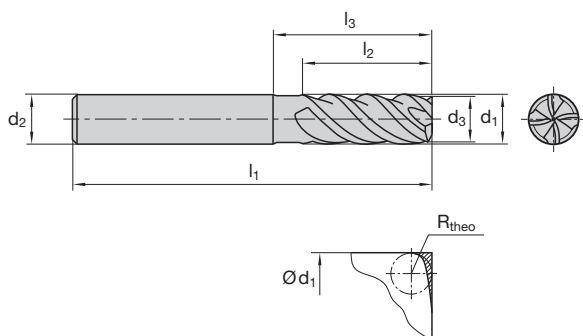

Cat.-No.										HFC01-P-A	
P										■	
M											
K										□	
N											
S											
H											
d ₁	d ₃	l ₂	l ₁	l ₃	d ₂	z	R _{theo}	a _{p max}	Ident No.	LMT-Code	
extra short											
2	1.85	3	40	5	4	2	0.2	0.1	7331800	EM-HFC01 P2.0x3/5 2R0.2HA	
3	2.85	4	50	7	6	2	0.3	0.15	7331801	EM-HFC01 P3.0x4/7 2R0.3HA	
4	3.8	5	54	9	6	4	0.4	0.2	7331802	EM-HFC01 P4.0x5/9 4R0.4HA	
5	4.8	6	54	11	6	4	0.5	0.25	7331803	EM-HFC01 P5.0x6/11 4R0.5HA	
6	5.7	7	54	13	6	4	0.6	0.3	7331804	EM-HFC01 P6.0x7/13 4R0.6HA	
8	7.7	9	58	17	8	4	0.8	0.4	7331805	EM-HFC01 P8.0x9/17 4R0.8HA	
10	9.7	11	66	22	10	4	1	0.5	7331806	EM-HFC01 P10.0x11/22 4R1.0HA	
12	11.7	13	73	26	12	4	1.2	0.6	7331807	EM-HFC01 P12.0x13/26 4R1.2HA	
short											
1	0.95	3	38	6	3	2	0.1	0.05	7331808	EM-HFC01 P1.0x3/6 2R0.1HA	
2	1.85	6	40	9	4	2	0.2	0.1	7331809	EM-HFC01 P2.0x6/9 2R0.2HA	
3	2.85	8	54	12	6	2	0.3	0.15	7331810	EM-HFC01 P3.0x8/12 2R0.3HA	
4	3.8	11	57	21	6	4	0.4	0.2	7331811	EM-HFC01 P4.0x11/17 4R0.4HA	
5	4.8	14	57	21	6	4	0.5	0.25	7331812	EM-HFC01 P5.0x14/18 4R0.5HA	
6	5.7	16	57	21	6	4	0.6	0.3	7331813	EM-HFC01 P6.0x16/21 4R0.6HA	
8	7.7	21	63	27	8	4	0.8	0.4	7331814	EM-HFC01 P8.0x21/27 4R0.8HA	
10	9.7	26	72	32	10	4	1	0.5	7331815	EM-HFC01 P10.0x26/32 4R1.0HA	
12	11.7	31	83	38	12	4	1.2	0.6	7331816	EM-HFC01 P12.0x31/38 4R1.2HA	
16	15.7	40	92	44	16	4	1.6	0.8	7331817	EM-HFC01 P16.0x40/44 4R1.6HA	
long											
4	3.8	11	70	24	6	4	0.4	0.2	7331818	EM-HFC01 P4.0x11/24 4R0.4HA	
5	4.8	14	70	30	6	4	0.5	0.25	7331819	EM-HFC01 P5.0x14/30 4R0.5HA	
6	5.7	16	80	35	6	4	0.6	0.3	7331820	EM-HFC01 P6.0x16/35 4R0.6HA	
8	7.7	21	80	40	8	4	0.8	0.4	7331821	EM-HFC01 P8.0x21/40 4R0.8HA	
10	9.7	26	90	45	10	4	1	0.5	7331822	EM-HFC01 P10.0x26/45 4R1.0HA	
12	11.7	31	100	50	12	4	1.2	0.6	7331823	EM-HFC01 P12.0x31/50 4R1.2HA	
extra long											
4	3.8	11	80	40	6	4	0.4	0.2	7331824	EM-HFC01 P4.0x11/40 4R0.4HA	
5	4.8	14	80	42	6	4	0.5	0.25	7331825	EM-HFC01 P5.0x14/42 4R0.5HA	
6	5.7	16	100	64	6	4	0.6	0.3	7331826	EM-HFC01 P6.0x16/64 4R0.6HA	
8	7.7	21	120	84	8	4	0.8	0.4	7331827	EM-HFC01 P8.0x21/84 4R0.8HA	
10	9.7	26	150	110	10	4	1	0.5	7331828	EM-HFC01 P10.0x26/110 4R1.0HA	
12	11.7	31	160	110	12	4	1.2	0.6	7331829	EM-HFC01 P12.0x31/110 4R1.2HA	
16	15.7	40	160	110	16	4	1.6	0.8	7331830	EM-HFC01 P16.0x40/110 4R1.6HA	

Cutting data recommendations starting page 6

■ = First Choice
□ = Second choice

Application Example

Machine Engineering



Tool:
 HFC01 Rougher P
 EM-HFC01 P12.0x31/38 4R1.2HA
 $d_1 = 12 \text{ mm}$, $z = 4$

Cutting material:
 LCPK40M

Material:
 1.2738/300–370 HB

Cutting data:
 $v_c = 200 \text{ m/min}$ $a_p = 0.5 \text{ mm}$
 $n = 5300 \text{ U/min}$ $a_e = 6 \text{ mm}$
 $f_z = 0.47 \text{ mm}$ $v_f = 10000 \text{ mm/min}$

Result:
 Significant time savings per component with simultaneous longer tool life.

Maximum productivity

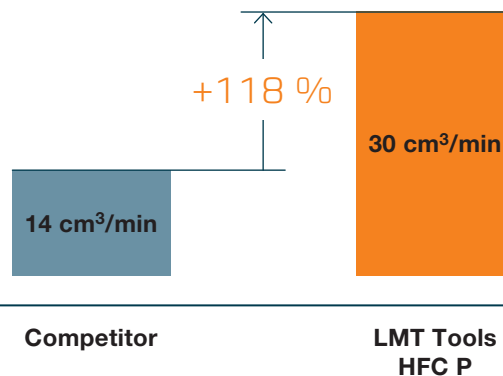

Long tool life

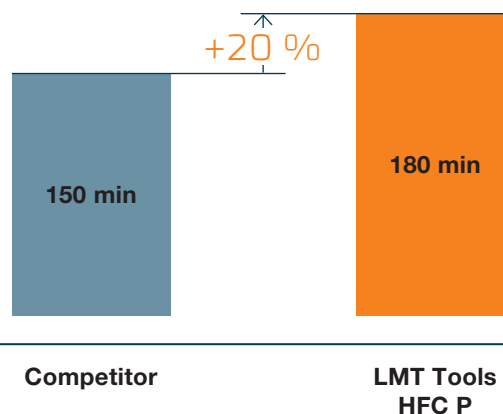

HFC01 Rougher P

Cutting data recommendations

Material	Material No.	DIN Description Old	R _m /UTS (N/mm ²)	DIN Description New	
P Plain carbon steel + free cutting steel	1.0570	St52-3	-700	S355J2G3	
	1.1730	C45	-800	C45U	
	1.0715	9SMn28	-700	11SMn30	
	1.1191	Ck45	500-950	C45E	
	1.7219	26CrMo4		26CrMo4-2	
	Heat-treatment steel, medium strength	1.7225	42CrMo4	500-950	42CrMo4
		1.8159	51CrV4		51CrV4
	Cast steel	1.0416	GS40	-950	GS40
	Case hardening steel	1.7131	16MnCr5	-950	16MnCr5
	Stainless steel, ferritic, martensitic	1.4006	X10Cr13	500-950	X12Cr13
		1.4104	X12CrMoS17		X14CrMoS17
		1.4122	X35CrMo17		X39CrMo17-1
	Heat-treatment steel, high strength	1.7225	42CrMo4	950-1400	42CrMo4
		1.6580	30CrNiMo8		30CrNiMo8
	Nitriding steel, heat treated	1.8504	34CrAl6	950-1400	34CrAl6
		1.2344	X40CrMoV5.1	-900	X40CrMoV5-1
	Tool steel	1.2343	X38CrMoV5 1	950-1400	X37CrMoV5-1
		1.2316	X38CrMo16	-1100	X38CrMo16
1.2379		X155CrVMo12 1	-950	X153CrMoV12-1	
1.2080		X210Cr12	950-1400	X210Cr12	
1.2358		60CrMoV18-5	850-1000	60CrMoV18-5	
1.2714		55NiCrMoV7	1100-1350	55NiCrMoV7	
1.2311		40CrMnMo7	-1100	40CrMnMo7	
1.2312	40CrMnNiMoS8.6	-1150	40CrMnNiMoS8-6		
1.2738	45CrMnNiMo8.6.4	950-1150	45CrMnNiMo8-6-4		
K Grey cast iron	0.6025	GG25	100-400 (120-260 HB)	EN-GJI-250	
	Alloyed grey cast iron	0.6678	GGL-NiCr35 2	150-250 (160-230 HB)	EN-GJLA-XNiCr35-2
	Nodular cast iron	0.7070	GGG70L	400-800 (120-310 HB)	EN-GJS-700-2U
		0.7060	GGG60		EN-GJS-600-3
	Malleable cast iron	0.8155	GTS55	350-700 (150-280 HB)	EN-GJMB-550-4

	Cutting speed v_c (m/min)	Cutting diameter (mm)				Cutting depth a_p (mm)
		Feed per tooth f_z (mm/z.)				
		Ø 1-3	Ø 4-6	Ø 8-10	Ø 12-16	
	300	0.30	0.50	0.70	1.00	0.05 x d_1
	300	0.30	0.50	0.70	1.00	
	300	0.30	0.50	0.70	1.00	
	240	0.25	0.40	0.60	0.80	
	200	0.25	0.40	0.60	0.80	
	240	0.25	0.40	0.60	0.80	
	200	0.25	0.40	0.60	0.80	0.045 x d_1
	200	0.25	0.40	0.60	0.80	
	180	0.25	0.40	0.60	0.80	0.04 x d_1
	220	0.25	0.40	0.60	0.80	0.04 x d_1
	200	0.20	0.40	0.50	0.70	
	200	0.25	0.40	0.60	0.80	
	200	0.25	0.40	0.60	0.80	
	250	0.50	0.70	0.90	1.30	0.04 x d_1
	250	0.45	0.60	0.80	1.20	
	180	0.20	0.30	0.50	0.70	
	180	0.30	0.50	0.70	1.00	
	150	0.30	0.50	0.70	1.00	

The cutting data indicated are starting values and must be adjusted to the prevailing conditions.
 We recommended to reduce the f_z -value with the long version by 30 %.

High Feed End Mills For Austenitic Steel

The new HFC01 Rougher M was especially developed for the machining of ISO-M materials. The 4-flute end mill already covers a broad range of applications in non-ferrous materials, super alloys and titanium with its standard

lengths extra short, short, long and extra long and the diameter range of 4–16 mm. All tools are with internal cooling system.

Features:

Extended lateral cutting edge, regrindable

45° helix angle

Central cooling





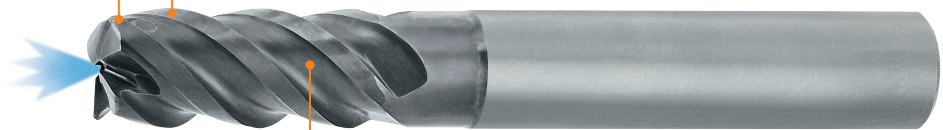

Similarity to "S-cutting edge"

Cutting grade LCMS30M

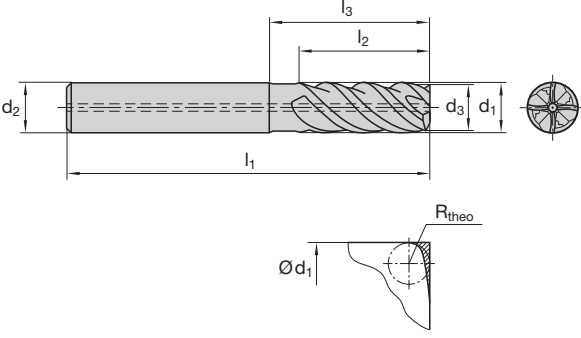

HFC01 Rougher M

High feed end mills for austenitic steels



   										HFC01-M-A	
											
Cat.-No.										HFC01-M-A	
P											
M										■	
K											
N											
S										□	
H											
d ₁	d ₃	l ₂	l ₁	l ₃	d ₂	z	R _{theo}	a _{p max}	Ident No.	LMT-Code	
extra short											
4	3.8	5	54	9	6	4	0.4	0.2	7331855	EM-HFC01 M4.0x5/9 4R0.4HA-I	
5	4.8	6	54	11	6	4	0.5	0.25	7331856	EM-HFC01 M5.0x6/11 4R0.5HA-I	
6	5.7	7	54	13	6	4	0.6	0.3	7331857	EM-HFC01 M6.0x7/13 4R0.6HA-I	
8	7.7	9	58	17	8	4	0.8	0.4	7331858	EM-HFC01 M8.0x9/17 4R0.8HA-I	
10	9.7	11	66	22	10	4	1	0.5	7331859	EM-HFC01 M10.0x11/22 4R1.0HA-I	
12	11.7	13	73	26	12	4	1.2	0.6	7331860	EM-HFC01 M12.0x13/26 4R1.2HA-I	
16	15.7	17	82	34	16	4	1.6	0.8	7331861	EM-HFC01 M16.0x17/34 4R1.6HA-I	
short											
4	3.8	11	57	16	6	4	0.4	0.2	7331862	EM-HFC01 M4.0x11/16 4R0.4HA-I	
5	4.8	14	57	18	6	4	0.5	0.25	7331863	EM-HFC01 M5.0x14/18 4R0.5HA-I	
6	5.7	16	57	21	6	4	0.6	0.3	7331864	EM-HFC01 M6.0x16/21 4R0.6HA-I	
8	7.7	21	63	27	8	4	0.8	0.4	7331865	EM-HFC01 M8.0x21/27 4R0.8HA-I	
10	9.7	26	72	32	10	4	1	0.5	7331866	EM-HFC01 M10.0x26/32 4R1.0HA-I	
12	11.7	31	83	38	12	4	1.2	0.6	7331867	EM-HFC01 M12.0x31/38 4R1.2HA-I	
16	15.7	40	92	44	16	4	1.6	0.8	7331868	EM-HFC01 M16.0x40/44 4R1.6HA-I	
long											
4	3.8	11	69	24	6	4	0.4	0.2	7331869	EM-HFC01 M4.0x11/24 4R0.4HA-I	
5	4.8	14	69	26	6	4	0.5	0.25	7331870	EM-HFC01 M5.0x14/26 4R0.5HA-I	
6	5.7	16	69	33	6	4	0.6	0.3	7331871	EM-HFC01 M6.0x16/33 4R0.6HA-I	
8	7.7	21	75	39	8	4	0.8	0.4	7331872	EM-HFC01 M8.0x21/39 4R0.8HA-I	
10	9.7	26	80	40	10	4	1	0.5	7331873	EM-HFC01 M10.0x26/40 4R1.0HA-I	
12	11.7	31	93	48	12	4	1.2	0.6	7331874	EM-HFC01 M12.0x31/48 4R1.2HA-I	
16	15.7	40	108	60	16	4	1.6	0.8	7331875	EM-HFC01 M16.0x40/60 4R1.6HA-I	
extra long											
4	3.8	11	69	29	6	4	0.4	0.2	7331876	EM-HFC01 M4.0x11/29 4R0.4HA-I	
5	4.8	14	69	30	6	4	0.5	0.25	7331877	EM-HFC01 M5.0x14/30 4R0.5HA-I	
6	5.7	16	75	39	6	4	0.6	0.3	7331878	EM-HFC01 M6.0x16/39 4R0.6HA-I	
8	7.7	21	83	47	8	4	0.8	0.4	7331879	EM-HFC01 M8.0x21/47 4R0.8HA-I	
10	9.7	26	95	55	10	4	1	0.5	7331880	EM-HFC01 M10.0x26/55 4R1.0HA-I	
12	11.7	31	110	65	12	4	1.2	0.6	7331881	EM-HFC01 M12.0x31/65 4R1.2HA-I	
16	15.7	40	125	77	16	4	1.6	0.8	7331882	EM-HFC01 M16.0x40/77 4R1.6HA-I	

Cutting data recommendations starting page 10

■ = First Choice
□ = Second choice

HFC01 Rougher M

Cutting data recommendations

Material	Material No.	DIN Description Old	R _m /UTS (N/mm ²)	DIN Description New	Coolant	
M Stainless steel, austenitic	1.4301	X2CrNiMo17-12-2	500–950	X5CrNiMo18-10		
	1.4404	X6CrNiMoTi17-12-2		X2CrNiMo17-12-2		
	1.4571	X10CrNiMoTi18		X10CrNiMoTi18		
	Stainless steel, ferritic, martensitic	1.2709	X3NiCoMoTi18-9-5	800–1000		X3NiCoMoTi18-9-5
		1.4542	X5CrNiCuNb16-4			X5CrNiCuNb16-4
		1.4568	X7CrNiAl17-7			X7CrNiAl17-7
Stainless steel, martensitic steel	1.2709	X3NiCoMoTi18-9-5	800–1000	X3NiCoMoTi18-9-5		
	1.4542	X5CrNiCuNb16-4		X5CrNiCuNb16-4		
	1.4568	X7CrNiAl17-7		X7CrNiAl17-7		
S Titanium alloys, medium strength	3.7164	TiAl6V4	–950	Ti6AlV4		
	3.7115	TiAl5Sn2,5		TiAl5Sn2-5		
	Titanium alloys, high strength	3.7174	TiAl6Sn2	900–1400		TiAl6V6Sn2
	Nickel based alloys, medium strength	2.4670	NiCr12Al6MoNb	–950		NiCr12Al6MoNb
	Heat resistant nickel based alloys, high strength	2.4668	NiCr19Fe19NbMo	900–1400		Inconel 718 NiCr19Fe19Nb5Mo3



Wet machining,
sufficient emulsion volume required

	Cutting speed v_c (m/min)	Cutting diameter (mm)			Cutting depth a_p (mm)
		Feed per tooth f_z (mm/z.)			
		Ø 4-6	Ø 8-10	Ø 12-16	
	180	0.50	0.50	0.70	0.02 x d_1
	180	0.40	0.50	0.70	
	180	0.40	0.50	0.70	
	170	0.40	0.50	0.70	0.02 x d_1
	170	0.40	0.50	0.70	
	140	0.30	0.40	0.50	
	90	0.30	0.40	0.50	
	70	0.30	0.40	0.50	

The cutting data indicated are starting values and must be adjusted to the prevailing conditions.

High Feed End Mills

For Hardened Steels up to 65 HRC

The new HFC01 Rougher H was specially developed for the machining of ISO-H materials. The end mill is equipped with a maximum amount of teeth (6–8) that,

combined with the lengths extra short, short and long, form an ideal product range. The diameter range for these tools is 4–20 mm.

Features:

Extended lateral cutting edge, regrindable

20° helix angle

Maximum number of teeth ($z = 6-8$)





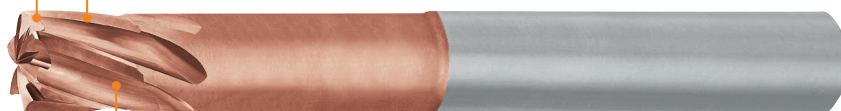
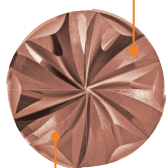

Negative cutting edges

Cutting grade LCHK20M

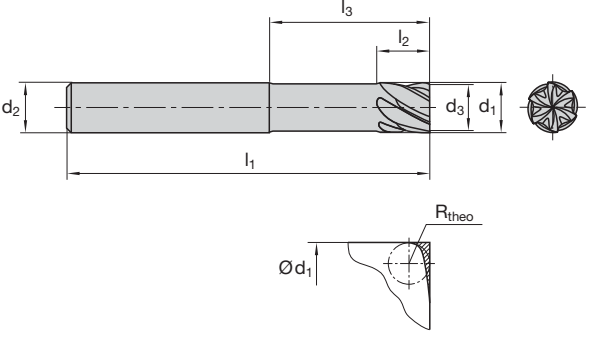

HFC01 Rougher H

High feed end mills for hardened steels up to 65 HRC

    										HFC01-H-A	
											
Cat.-No.										HFC01-H-A	
P										<input type="checkbox"/>	
M										<input type="checkbox"/>	
K										<input type="checkbox"/>	
N										<input type="checkbox"/>	
S										<input type="checkbox"/>	
H										<input checked="" type="checkbox"/>	
d ₁	d ₃	l ₂	l ₁	l ₃	d ₂	z	R _{theo}	a _{p max}	Ident No.	LMT-Code	
extra short											
4	3.8	4	57	9	6	6	0.4	0.2	7331831	EM-HFC01 H4.0x4/9 6R0.4HA	
5	4.8	5	57	11	6	6	0.5	0.25	7331832	EM-HFC01 H5.0x6/11 6R0.5HA	
6	5.7	6	57	13	6	6	0.6	0.3	7331833	EM-HFC01 H6.0x6/13 6R0.6HA	
8	7.6	8	63	17	8	6	0.8	0.4	7331834	EM-HFC01 H8.0x8/17 6R0.8HA	
10	9.5	10	72	22	10	6	1	0.5	7331835	EM-HFC01 H10.0x10/22 6R1.0HA	
12	11.5	12	83	26	12	6	1.2	0.6	7331836	EM-HFC01 H12.0x12/26 6R1.2HA	
16	15.5	16	92	34	16	8	1.6	0.8	7331837	EM-HFC01 H16.0x16/34 8R1.6HA	
20	19.5	20	104	42	20	8	2	1	7331838	EM-HFC01 H20.0x20/42 8R2.0HA	
short											
4	3.8	4	57	15	6	6	0.4	0.2	7331839	EM-HFC01 H4.0x4/15 6R0.4HA	
5	4.8	5	57	16	6	6	0.5	0.25	7331840	EM-HFC01 H5.0x6/16 6R0.5HA	
6	5.7	6	57	19	6	6	0.6	0.3	7331841	EM-HFC01 H6.0x6/19 6R0.6HA	
8	7.6	8	63	25	8	6	0.8	0.4	7331842	EM-HFC01 H8.0x8/25 6R0.8HA	
10	9.5	10	72	32	10	6	1	0.5	7331843	EM-HFC01 H10.0x10/32 6R1.0HA	
12	11.5	12	83	38	12	6	1.2	0.6	7331844	EM-HFC01 H12.0x12/38 6R1.2HA	
16	15.5	16	100	50	16	8	1.6	0.8	7331845	EM-HFC01 H16.0x16/50 8R1.6HA	
20	19.5	20	114	62	20	8	2	1	7331846	EM-HFC01 H20.0x20/62 8R2.0HA	
long											
4	3.8	4	70	24	6	6	0.4	0.2	7331847	EM-HFC01 H4.0x4/24 6R0.4HA	
5	4.8	5	70	30	6	6	0.5	0.25	7331848	EM-HFC01 H5.0x6/30 6R0.5HA	
6	5.7	6	80	35	6	6	0.6	0.3	7331849	EM-HFC01 H6.0x6/35 6R0.6HA	
8	7.6	8	80	40	8	6	0.8	0.4	7331850	EM-HFC01 H8.0x8/40 6R0.8HA	
10	9.5	10	90	45	10	6	1	0.5	7331851	EM-HFC01 H10.0x10/45 6R1.0HA	
12	11.5	12	100	50	12	6	1.2	0.6	7331852	EM-HFC01 H12.0x12/50 6R1.2HA	
16	15.5	16	120	66	16	8	1.6	0.8	7331853	EM-HFC01 H16.0x16/66 8R1.6HA	
20	19.5	20	135	82	20	8	2	1	7331854	EM-HFC01 H20.0x20/82 8R2.0HA	

Cutting data recommendations starting page 14

■ = First Choice
□ = Second choice

HFC01 Rougher H

Cutting data recommendations

Material	Material No.	DIN Description Old	R _m /UTS (N/mm ²)	DIN Description New	
P	Heat-treatable die steels	1.2311	-1100	40CrMnMo7	
		1.2312		40CrMnMoS8.6	
		1.2738		40CrMnNiMoS8.6.4	
		1.2711		54NiCrMoV6	
	Full hardening tool steels	1.2343	X38CrMoV5 1	350-1400	X37CrMoV5 1
		1.2080	X210Cr12		X210Cr12
		1.2379	X153CrVMo12 1		X153CrVMo12 1
		1.2767	X45NiCrMo4		X45NiCrMo4
	Nitriding steels	1.8550	34CrAlNi7	950-1400	34CrAlNi7
		1.8519	31CrMoV9		31CrMoV9
		1.7735	14CrMoV6.9		14CrMoV6.9
		1.2344	X40CrMoV5.1		X40CrMoV5-1
K	Grey cast iron	0.6025	GG25	100-400 (120-260 HB)	EN-GJI-250
	Alloyed grey cast iron	0.6678	GGL-NiCr35 2	150-250 (160-230 HB)	EN-GJLA-XNiCr35-2
	Nodular cast iron	0.7060	GGG60	400-800 (120-310 HB)	EN-GJS-600-3
		0.7070	GGG70L		EN-GJS-700-2U
Malleable cast iron	0.8155	GTS55	350-700 (150-280 HB)	EN-GJMB-550-4	
H	Hardened steel			45-52 HRC	
				53-56 HRC	
				57-62 HRC	
				63-68 HRC	

	Cutting speed v_c (m/min)	Cutting diameter (mm)						Cutting depth a_p (mm)
		Feed per tooth f_z (mm/z.)						
		Ø 4	Ø 5	Ø 6	Ø 8	Ø 10	Ø 12-20	
	240	0.30	0.38	0.45	0.60	0.75	0.90	0.05 x d_1 (= $a_{p\ max}$)
	220	0.30	0.38	0.45	0.60	0.75	0.90	
	200	0.24	0.30	0.36	0.48	0.60	0.70	
	200	0.28	0.35	0.42	0.56	0.70	0.85	0.04 x d_1
	180	0.26	0.33	0.39	0.52	0.65	0.80	
	160	0.24	0.30	0.36	0.48	0.60	0.70	
	200	0.28	0.35	0.42	0.56	0.70	0.85	0.04 x d_1
	180	0.26	0.33	0.39	0.52	0.65	0.80	
	160	0.24	0.30	0.36	0.48	0.60	0.70	
	200	0.35	0.40	0.55	0.65	0.80	0.95	0.05 x d_1
	180	0.30	0.35	0.50	0.60	0.75	0.90	
	180	0.30	0.35	0.50	0.60	0.75	0.90	
	160	0.30	0.35	0.50	0.60	0.75	0.90	
	160-180	0.16	0.20	0.24	0.32	0.40	0.48	0.04 x d_1
	120-160	0.12	0.15	0.18	0.24	0.30	0.36	0.03 x d_1
	100-120	0.08	0.10	0.12	0.16	0.20	0.24	0.02 x d_1
	80-100	0.06	0.08	0.09	0.12	0.15	0.18	0.01 x d_1

The cutting data indicated are starting values and must be adjusted to the prevailing conditions.
We recommended to reduce the f_z -value with the long version by 30 %.

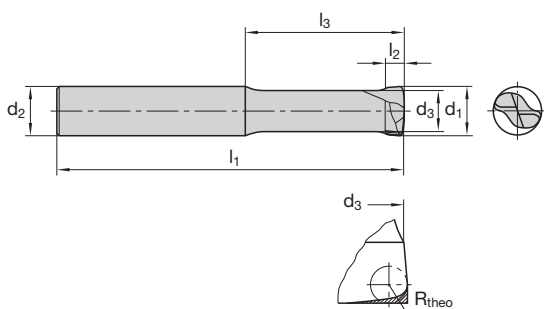

Cat.-No.										HFC01-U-A	
P											■
M											■
K											■
N											
S											
H											□
O											
d ₁	d ₃	l ₂	l ₁	l ₃	d ₂	z	R _{theo}	a _{p max}	Ident No.	LMT-Code	
extra short											
1	0.8	0.35	40	2	3	2	0.1	0.05	1300994	EM-HFC01 U1.0x0.35/2 2R0.1HA	
2	1.6	0.7	40	4	4	2	0.2	0.1	1300995	EM-HFC01 U2.0x0.7/4 2R0.2HA	
3	2.5	1	50	6	6	2	0.3	0.15	1300996	EM-HFC01 U3.0x1/6 2R0.3HA	
4	3.4	1.5	57	8	6	2	0.4	0.2	1301100	EM-HFC01 U4.0x1.5/8 2R0.4HA	
5	4.2	2	57	10	6	2	0.5	0.25	1301101	EM-HFC01 U5.0x2/10 2R0.5HA	
6	5	2.5	57	12	6	2	0.6	0.3	1301102	EM-HFC01 U6.0x2.5/12 2R0.6HA	
8	6.7	3	63	16	8	2	0.8	0.4	1301103	EM-HFC01 U8.0x3/16 2R0.8HA	
10	8.5	3.5	72	20	10	2	1	0.5	1301104	EM-HFC01 U10.0x3.5/20 2R1.0HA	
12	10	4	83	24	12	2	1.2	0.6	1301105	EM-HFC01 U12.0x4/24 2R1.2HA	
14	11.8	4	83	28	14	2	1.4	0.7	1301106	EM-HFC01 U14.0x4/28 2R1.4HA	
short											
1	0.8	0.35	40	4	3	2	0.1	0.05	1300997	EM-HFC01 U1.0x0.35/4 2R0.1HA	
2	1.6	0.7	40	8	4	2	0.2	0.1	1300998	EM-HFC01 U2.0x0.7/8 2R0.2HA	
3	2.5	1	57	12	6	2	0.3	0.15	1300999	EM-HFC01 U3.0x1/12 2R0.3HA	
4	3.4	1.5	57	15	6	2	0.4	0.2	1110170	EM-HFC01 U4.0x1.5/15 2R0.4HA	
5	4.2	2	57	17.5	6	2	0.5	0.25	1110171	EM-HFC01 U5.0x2/17.5 2R0.5HA	
6	5	2.5	57	19	6	2	0.6	0.3	1110172	EM-HFC01 U6.0x2.5/19 2R0.6HA	
8	6.7	3	63	24	8	2	0.8	0.4	1110173	EM-HFC01 U8.0x3/24 2R0.8HA	
10	8.5	3.5	72	28.5	10	2	1	0.5	1110174	EM-HFC01 U10.0x3.5/28.5 2R1.0HA	
12	10	4	83	34	12	2	1.2	0.6	1110175	EM-HFC01 U12.0x4/34 2R1.2HA	
16	13.5	5.5	92	39	16	2	1.6	0.8	1110176	EM-HFC01 U16.0x5.5/39 2R1.6HA	
20	17	7	104	48	20	2	2	1	1110177	EM-HFC01 U20.0x7/48 2R2.0HA	
long											
4	3.4	1.5	70	24	6	2	0.4	0.2	1300988	EM-HFC01 U4.0x1.5/24 2R0.4HA	
5	4.2	2	70	30	6	2	0.5	0.25	1300989	EM-HFC01 U5.0x2/30 2R0.5HA	
6	5	2.5	80	35	6	2	0.6	0.3	1300990	EM-HFC01 U6.0x2.5/35 2R0.6HA	
8	6.7	3	80	40	8	2	0.8	0.4	1300991	EM-HFC01 U8.0x3/40 2R0.8HA	
10	8.5	3.5	90	45	10	2	1	0.5	1300992	EM-HFC01 U10.0x3.5/45 2R1.0HA	
12	10	4	100	50	12	2	1.2	0.6	1300993	EM-HFC01 U12.0x4/50 2R1.2HA	

Cutting data recommendations starting page 18

■ = First Choice
□ = Second choice

HFC01 Rougher UNI

Universal high feed end mills

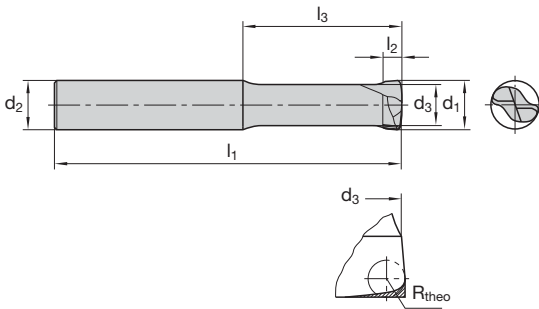

Cat.-No.										HFC01-U-A	
P											■
M											■
K											■
N											
S											
H											□
O											
d ₁	d ₃	l ₂	l ₁	l ₃	d ₂	z	R _{theo}	a _{p max}	Ident No.	LMT-Code	
extra long											
4	3.4	1.5	80	34	6	2	0.4	0.2	1110180	EM-HFC01 U4.0x1.5/34 2R0.4HA	
5	4.2	2	80	37	6	2	0.5	0.25	1110181	EM-HFC01 U5.0x2/37 2R0.5HA	
6	5	2.5	80	42	6	2	0.6	0.3	1110182	EM-HFC01 U6.0x2.5/42 2R0.6HA	
8	6.7	3	90	51	8	2	0.8	0.4	1110183	EM-HFC01 U8.0x3/51 2R0.8HA	
10	8.5	3.5	100	56.5	10	2	1	0.5	1110184	EM-HFC01 U10.0x3.5/56.5 2R1.0HA	
12	10	4	110	61	12	2	1.2	0.6	1110185	EM-HFC01 U12.0x4/61 2R1.2HA	
16	13.5	5.5	130	77	16	2	1.6	0.8	1110186	EM-HFC01 U16.0x5.5/77 2R1.6HA	
20	17	7	150	94	20	2	2	1	1110187	EM-HFC01 U20.0x7/94 2R2.0HA	

Cutting data recommendations starting page 18

■ = First Choice
□ = Second choice

HFC01 Rougher UNI

Cutting data recommendations

Material	Material No.	DIN Description Old	R _m /UTS (N/mm ²)	DIN Description New	
P Plain carbon steel + free cutting steel	1.0570	St52-3	-700	S355J2G3	
	1.1730	C45	-800	C45U	
	1.0715	9SMn28	-700	11SMn30	
	1.1191	Ck45	500-950	C45E	
	1.7219	26CrMo4		26CrMo4-2	
	Heat-treatment steel, medium strength	1.7225	42CrMo4	500-950	42CrMo4
		1.8159	51CrV4		51CrV4
	Cast steel	1.0416	GS40	-950	GS40
	Case hardening steel	1.7131	16MnCr5	-950	16MnCr5
	Stainless steel, ferritic, martensitic	1.4006	X10Cr13	500-950	X12Cr13
		1.4104	X12CrMoS17		X14CrMoS17
		1.4122	X35CrMo17		X39CrMo17-1
	Heat-treatment steel, high strength	1.7225	42CrMo4	950-1400	42CrMo4
		1.6580	30CrNiMo8		30CrNiMo8
	Nitriding steel, heat treated	1.8504	34CrAl6	950-1400	34CrAl6
		1.2344	X40CrMoV5.1	-900	X40CrMoV5-1
	Tool steel	1.2343	X38CrMoV5 1	950-1400	X37CrMoV5-1
1.2316		X38CrMo16	-1100	X38CrMo16	
1.2379		X153CrVMo12 1	-950	X153CrMoV12-1	
1.2080		X210Cr12	950-1400	X210Cr12	
1.2358		60CrMoV18-5	850-1000	60CrMoV18-5	
1.2714		55NiCrMoV7	1100-1350	55NiCrMoV7	
1.2311		40CrMnMo7	-1100	40CrMnMo7	
1.2312	40CrMnNiMoS8.6	-1150	40CrMnNiMoS8-6		
1.2738	45CrMnNiMo8.6.4	950-1150	45CrMnNiMo8-6-4		
M Stainless steel, austenitic	1.4301	X2CrNiMo17-12-2	500-950	X5CrNiMo18-10	
	1.4404	X6CrNiMoTi17-12-2		X2CrNiMo17-12-2	
	1.4571	X10CrNiMoTi18		X10CrNiMoTi18	
	Stainless steel, martensitic steel	1.2709	X3NiCoMoTi18-9-5	800-1000	X3NiCoMoTi18-9-5
		1.4542	X5CrNiCuNb16-4		X5CrNiCuNb16-4
		1.4568	X7CrNiAl17-7		X7CrNiAl17-7
K Grey cast iron	0.6025	GG25	100-400 (120-260 HB)	EN-GJI-250	
	Alloyed grey cast iron	0.6678	GGL-NiCr35 2	150-250 (160-230 HB)	EN-GJLA-XNiCr35-2
		Nodular cast iron	0.7070	GGG70L	400-800
	0.7060		GGG60	(120-310 HB)	EN-GJS-600-3
	Malleable cast iron	0.8155	GTS55	350-700 (150-280 HB)	EN-GJMB-550-4
H Chilled cast iron		Ni-hard, Ampco	300-600 HB	Ni-hard, Ampco	
	Hardened steel		45-52 HRC		

	Cutting speed v_c (m/min)	Cutting diameter (mm)			Cutting depth a_p (mm)
		Feed per tooth f_z (mm/z.)			
		Ø 1-4	Ø 5-10	Ø 12-20	
	300	0.30	0.70	1.00	0.05 x d_1
	300	0.30	0.70	1.00	
	300	0.30	0.70	1.00	
	240	0.25	0.60	0.80	
	200	0.25	0.60	0.80	
	240	0.25	0.60	0.80	
	200	0.25	0.60	0.80	0.045 x d_1
	200	0.25	0.60	0.80	
	180	0.25	0.60	0.80	0.04 x d_1
	220	0.25	0.60	0.80	0.04 x d_1
	200	0.20	0.50	0.70	
	200	0.25	0.60	0.80	
	230	0.20	0.50	0.70	0.02 x d_1
	230	0.20	0.50	0.70	
	250	0.50	0.90	1.30	0.04 x d_1
	250	0.45	0.80	1.20	
	180	0.20	0.50	0.70	
	180	0.30	0.70	1.00	
	150	0.30	0.70	1.00	
	100	0.20	0.50	0.70	0.03 x d_1
	160-180	0.15	0.30	0.50	

The cutting data indicated are starting values based on Ø 10 mm and must be adjusted to the prevailing conditions. We recommended to reduce the f_z -value with the long version by 30 %.

Publication details

Publisher: LMT Tools Global Operations GmbH & Co. KG,
 Vogesenstrasse 23, 77933 Lahr, Germany, Phone: +49 7821 943-0
 Responsible for the content: Norman Winter, LMT Tool Systems GmbH & Co. KG
 Design: deckermedia GbR, Rostock
 Printing: Druckerei Weidner GmbH, Rostock

© LMT Tools Global Operations GmbH & Co. KG

This publication may not be reprinted in whole or part without our express permission. All right reserved. No rights may be derived from any errors in content or from typographical or typesetting errors. Diagrams, features and dimensions represent the current status on the date of issue of this catalog. We reserve the right to make technical changes. The visual appearance of the products may not necessarily correspond to the actual appearance in all cases or in every detail.
 Sources: LMT Tools Global Operations GmbH & Co. KG und LMT Tool Systems GmbH & Co. KG

