

A background image showing three business professionals in a meeting. A man in a dark suit is shaking hands with a woman in a light grey blazer, with another man in a dark suit standing behind her. The scene is set in a modern office with large windows.

# UltraMelt GameChanger für eine nachhaltigere Produktion

Mathias Linn – General Sales Manager, Hot Runners & Controller  
February 26, 2026

**HUSKY**<sup>®</sup>

# ENABLE CUSTOMERS GLOBALLY TO DELIVER ESSENTIAL GOODS AND ICONIC BRANDS

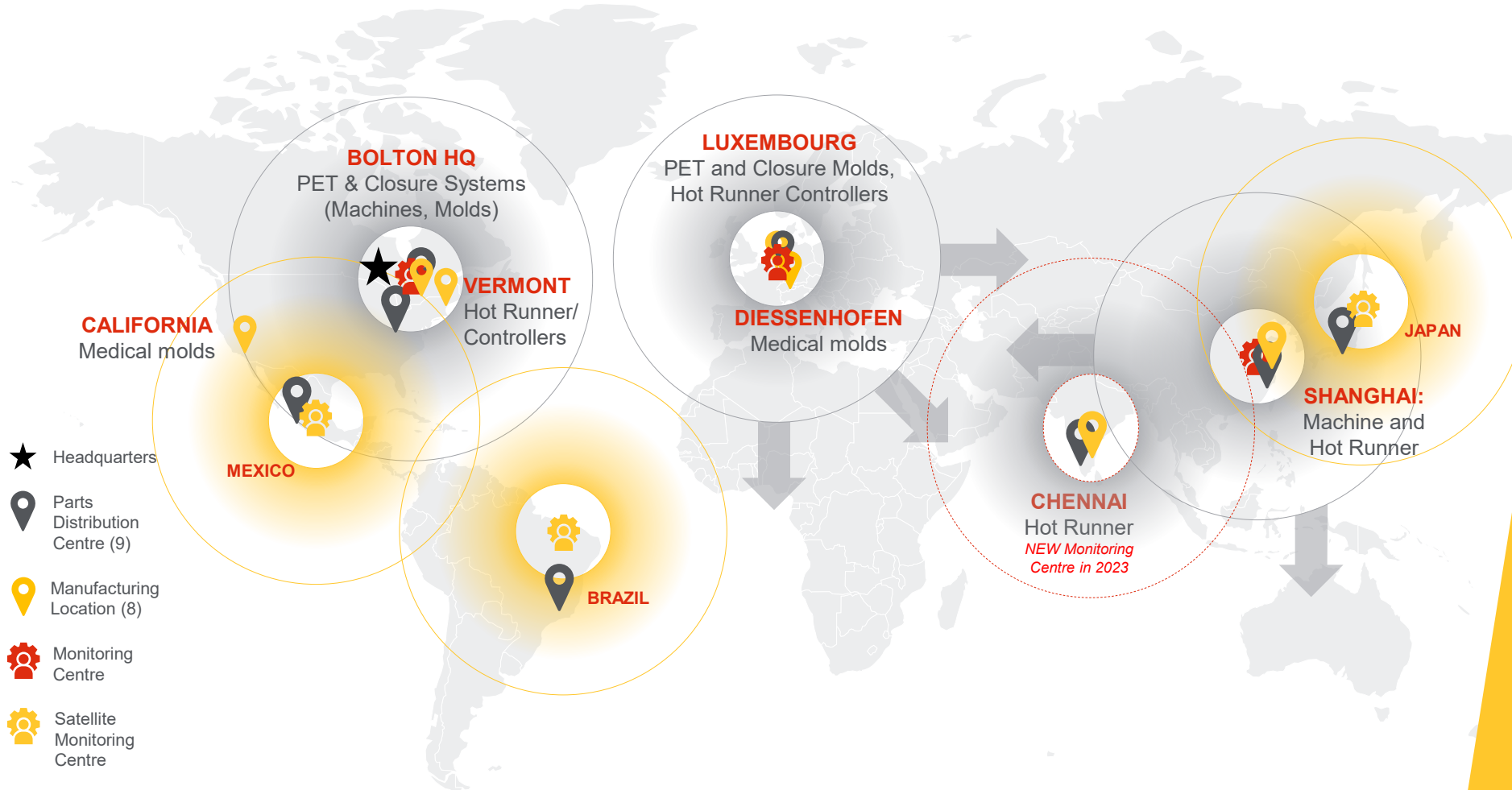

AND MAINTAINED COMMITMENT MADE DELIVERED

**40**  
SALES AND SERVICE LOCATIONS

JEFFERSONVILLE | MEXICO | BRAZIL | LUXEMBOURG | MOSCOW | SHANGHAI | CHENNAI

**9**  
PARTS DISTRIBUTION CENTERS

BOLTON | YOKOHAMA

BOLTON | VERMONT | LUXEMBOURG | DIESSENHOFEN | CHENNAI

**7**  
MANUFACTURING LOCATIONS

CALIFORNIA | SHANGHAI

HUSKY CONTROLLED. HUSKY INFORMATION IS ONLY INTENDED FOR THE RECIPIENT.  
ANY DISSEMINATION TO ANYONE OTHER THAN THE RECIPIENT IS UNAUTHORIZED AND STRICTLY PROHIBITED.

**HUSKY®**

# SERVING THE ESSENTIAL NEED'S MARKET

OUR MARKET

## BEVERAGE



## MEDICAL



## FOOD



## CONSUMER GOODS



OUR SOLUTION

- PET Systems & Tooling
- Closure Systems & Tooling
- Advisory Services

- Hot Runner & Controller
- Medical Schöttli tooling
- Medical System

- PET Systems & Tooling
- Closure Systems & Tooling
- Packaging System
- Hot Runner & Controller
- Advisory Services

- Packaging Systems
- Closure Systems & Tooling
- Hot Runner & Controller

# WHAT WE ARE HEARING FROM OUR CUSTOMERS

## MEET SUSTAINABILITY GOALS

Reduce the use of Virgin Resin



Increase PCR Content

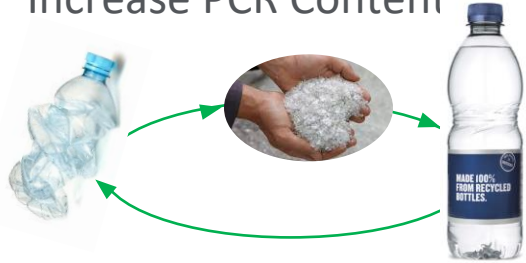

Meeting regulatory requirements



Convert to recyclable or compostable polymers



## DE-RISK THE SUPPLY CHAIN

Remove supply constraints to enable growth

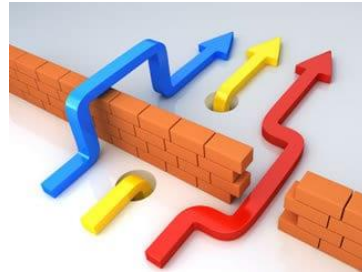

Ensure on-time delivery and enhanced quality



## PREPARE FOR THE TALENT CRISIS

Global shortage of skilled labor

*"The Silver Tsunami"*

**Talent Crisis**  
Due to aging population & willingness to work

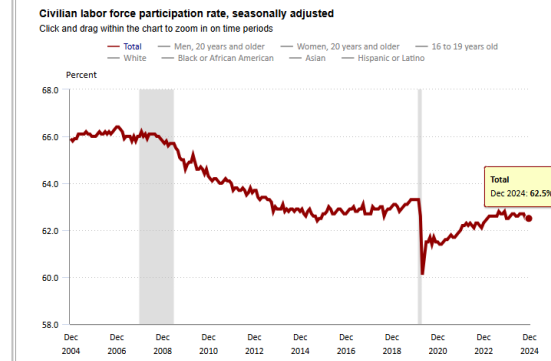

<https://www.bls.gov/charts/employment-situation/civilian-labor-force-participation-rate.htm>

- Optimizing production
- System approach
- Proactive monitoring
- **We Call You**



## ADDRESS INFLATION AND RISING ENERGY COSTS

INFLATION – Jan 2019 - Jul 2023

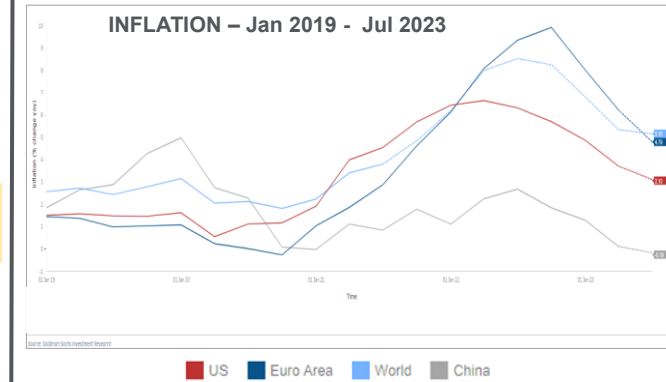

**Natural gas and oil comparison**  
(updated till 03 August 2023)

■ ICIS Brent Month +1 Closing value  
■ ICIS TTF Price Assessment Month +1 Bid-offer range

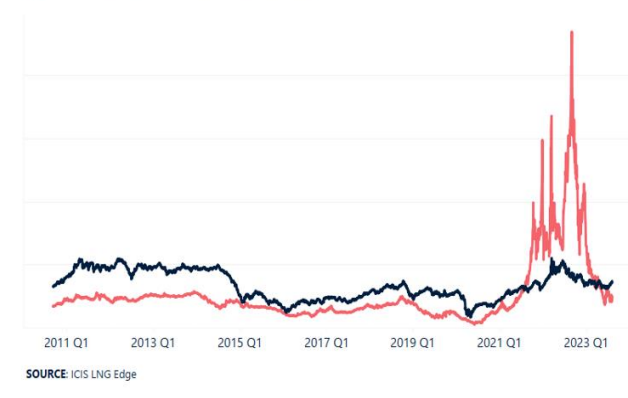

# HUSKY – WE ARE INVESTING TO SUPPORT OUR CUSTOMERS

**LOWEST TOTAL COST OF OWNERSHIP**

**SUSTAINABILITY**



**SPEED AND QUALITY**

**SYSTEM BASED SOLUTIONS**

**PROTECT SENSITIVE PRODUCTS**

**COMMITMENT**

**Enabling World Class Producer**

**Uniting Global Voices**  
Plastics are Essential



**35+ Customers Attended**  
**15+ Associations Joined**

**Tethered and PET closures**



**rMtP**



**Factory of the Future**  
End to End Full industrialization



**Fully Digitized Delivery Model**

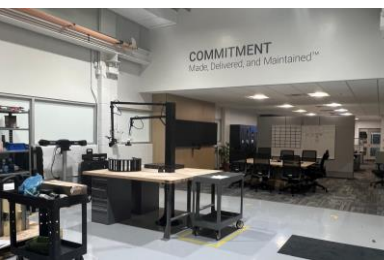

**ANDON Clinic**  
Quality at the source

**Preform Systems**



**Closure Systems**



**Medical & UltraShot Systems**



**Modular Packaging Systems**



**Better Food & Beverage Protection**  
*Enhanced PET with Multi-Layer*



**Enhanced Packaging & Medical Applications with Multi-Layer**



**Commitment**  
Made, Delivered and Maintained



**HUSKY Advantage+Elite™**  
WE CALL YOU



**40 SALES AND SERVICE LOCATIONS**    **9 PARTS DISTRIBUTION CENTERS**    **7 MANUFACTURING LOCATIONS**



# A Few Notes on Husky HRC

- ✓ Industry-leading hot runners and controllers for mold makers, converters, and brand owners
- ✓ Our vision is to be recognized for the highest quality and the most reliable hot runners while providing the shortest time-to-market
- ✓ Facilities in key global manufacturing areas with Standardized engineering and manufacturing processes and a Global footprint = Global quality

## Unique Products



Altanium®

- Scalable software platform provides capability to grow as needed without replacing the entire controller
- Superior measurement and control accuracy



UltraSync®

- Fully configurable synchronized Valve Gate activation
- Unmatched consistency and repeatability cycle after cycle



Ultra Helix™

- Gate life lasts for millions of cycles, longer than any other valve gate available
- Ringier Technology Innovation Award winner

HUSKY CONTROLLED. HUSKY INFORMATION IS ONLY INTENDED FOR THE RECIPIENT. ANY DISSEMINATION TO ANYONE OTHER THAN THE RECIPIENT IS UNAUTHORIZED AND STRICTLY PROHIBITED.

## Global Manufacturing Excellence



Milton, VT, USA (23,000 m<sup>2</sup>)



Shanghai, China (10,000 m<sup>2</sup>)



Dudelange, Luxembourg (20,000 m<sup>2</sup>)



Chennai, India (5,000 m<sup>2</sup>)

## Market Segments

## Selected Applications

High  
Performance

Mid-range  
Performance



**HUSKY**®

# SUSTAINABILITY GOALS AND ADVOCACY



**HUSKY**<sup>®</sup>

# OUR PURPOSE

Enabling healthy and sustainable livelihoods globally

A person in a red kayak is paddling down a river. The water is greenish and there are rocky banks on either side. The scene is captured from a low angle, looking back at the kayaker.

SUSTAINABLE

A close-up shot of two hands wearing blue nitrile gloves. One hand is holding a small glass vial, and the other is holding a syringe, as if preparing a dose of medication.

LIVELIHOODS

A woman with her hair in braids, wearing a blue t-shirt, is smiling broadly. In the background, other people are visible, some also wearing blue shirts, suggesting a community or organizational setting.

GLOBALLY

# HUSKY'S SUSTAINABILITY VISION

A pair of hands is shown from the bottom left, cupping a glowing, geometric, circular logo. The logo is composed of many small, interconnected triangles, creating a mesh-like structure. The background is a dark green gradient with scattered, glowing particles in shades of green and orange, giving it a futuristic and sustainable feel.

We innovate and advocate for sustainable solutions that enable a circular, zero-waste future for the health and well-being of people and the planet.

# SUSTAINABILITY ADVOCACY HUSKY STRATEGY AT A GLANCE



## PLASTIC:

- ✓ **Provides a barrier** to natural hazards, light, oxygen, dirt, and 1,400 naturally occurring bacteria considered pathogens
- ✓ Allows for **accessible, affordable healthcare**
- ✓ **Reduces food waste**
- ✓ Enables **clean water access**



# EDUCATING POLICY MAKERS

HUSKY CONTROLLED. HUSKY INFORMATION IS ONLY INTENDED FOR THE RECIPIENT.  
ANY DISSEMINATION TO ANYONE OTHER THAN THE RECIPIENT IS UNAUTHORIZED AND STRICTLY PROHIBITED.

# INC-5 | NOV 25-DEC 1, 2024 IN BUSAN, KOREA

In March 2022, the UNEP created an Intergovernmental Negotiating Committee (INC) to establish an “internationally legally binding instrument on plastic pollution, including the marine environment.”

**INC-5** was meant to be the 5<sup>th</sup> and final meeting and conclusion to the negotiations.



# UNEP INC TIMELINE



# THE SOLUTION: MOVING FROM A LINEAR TO CIRCULAR ECONOMY

## LINEAR ECONOMY



TAKE

MAKE

WASTE

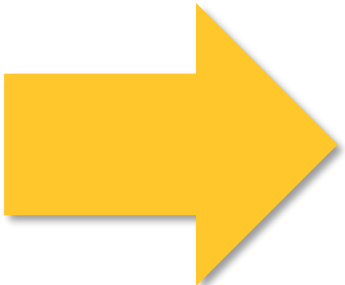

## CIRCULAR ECONOMY



# THE HUSKY EXPERIENCE

INDUSTRY-LEADING PERFORMANCE DOESN'T HAPPEN BY ACCIDENT.

**EVERY INTERACTION WITH HUSKY** IS DESIGNED TO HELP OUR CUSTOMERS SUCCEED, FROM SALES TO CONFIGURATION TO SERVICE.

**OUR CULTURE OF EXCELLENCE AND COMMITMENT TO CUSTOMERS** MAKES US TRUSTED ADVISORS THAT MANAGE RISK AND DRIVE PROFITABILITY.

THOUSANDS OF OUR CUSTOMERS GET THE HUSKY EXPERIENCE EVERY DAY.

**ARE YOU READY TO JOIN THEM?**



# ULTRAMELT

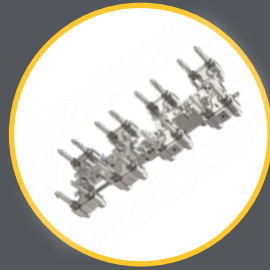

HUSKY CONTROLLED. HUSKY INFORMATION IS ONLY INTENDED FOR THE RECIPIENT.  
ANY DISSEMINATION TO ANYONE OTHER THAN THE RECIPIENT IS UNAUTHORIZED AND STRICTLY PROHIBITED.

**HUSKY**<sup>®</sup>

# RECOGNITION FOR HUSKY'S BIOPLASTICS INNOVATION

Husky named winner of the **PLASTICS' 2023 Innovation in Bioplastics Award** for the pioneering work on our UltraMelt™ hot runner technology, significantly enhancing the quality of injection molding with bioplastics and bioresins.

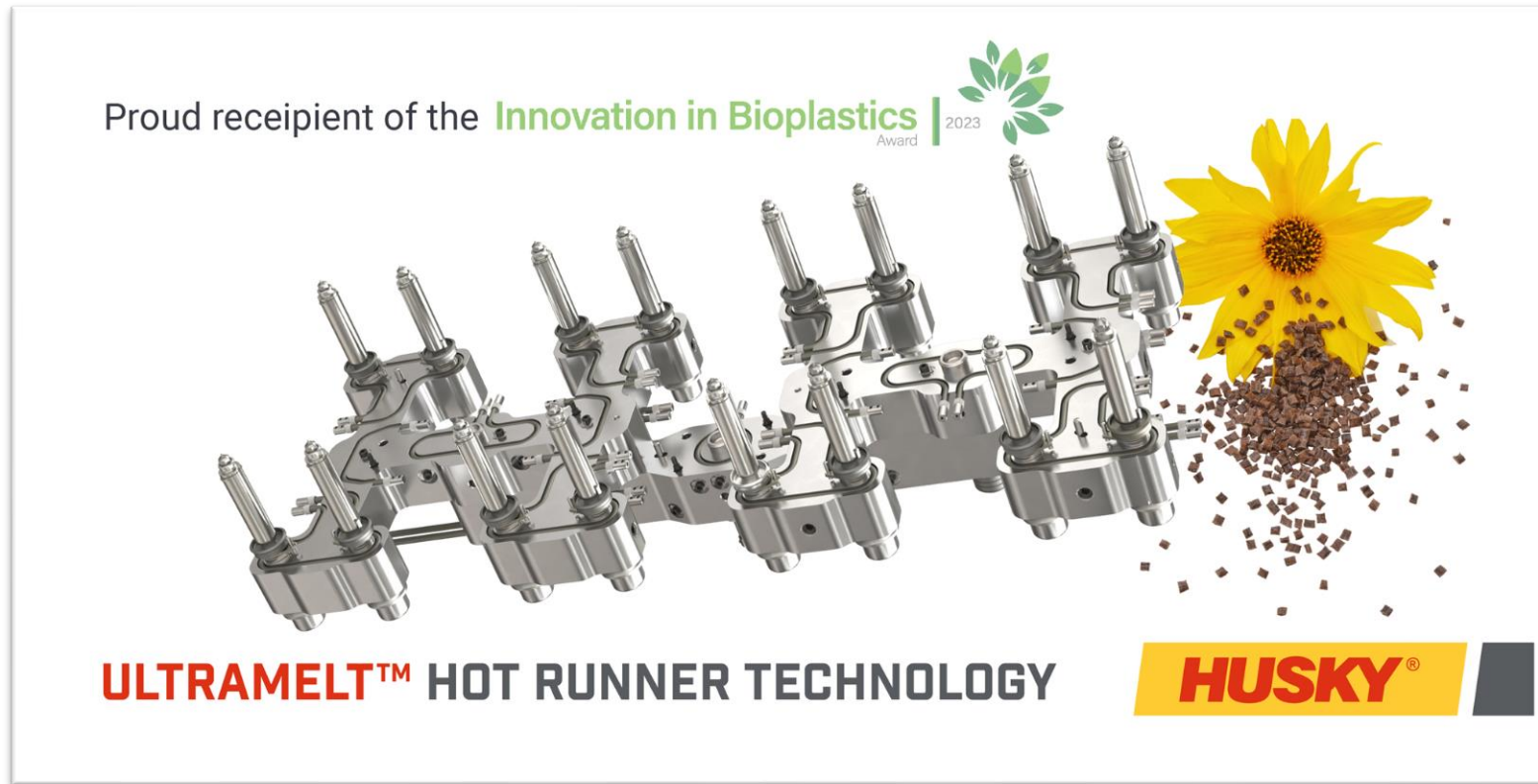

# WHAT IS ULTRAMELT?

## PRODUCT DEFINITION

UltraMelt is Husky's premium solution for applications requiring excellent process and thermal control with a minimal effect to the resin chemistry.

Intended market:

- Medical (minimal variation)
- Small parts (degradation risk minimized)
- Transparent or light-colored parts (detection)
- Heat sensitive (degradation & chemistry)

Future market:

- Corrosive (chemistry)
- PLA/PHA (bioresins)
- PVC

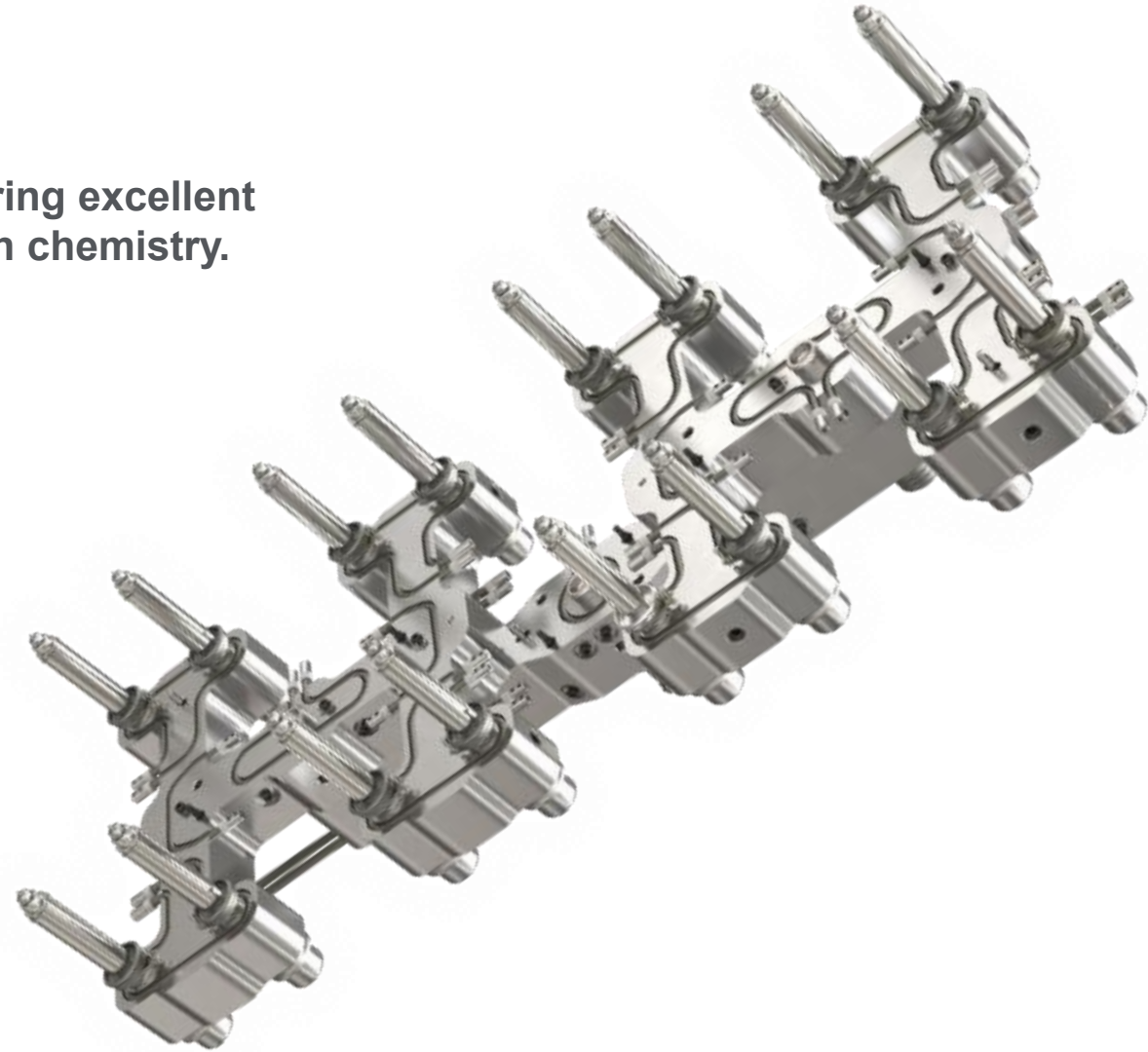

# ALTANIUM MOLD CONTROLLERS



HUSKY CONTROLLED. HUSKY INFORMATION IS ONLY INTENDED FOR THE RECIPIENT.  
ANY DISSEMINATION TO ANYONE OTHER THAN THE RECIPIENT IS UNAUTHORIZED AND STRICTLY PROHIBITED.

**HUSKY**<sup>®</sup>

# ALTANIUM MOLD CONTROLLERS

**Altanium**

is a highly integrated platform for the injection molding industry that provides accurate and repeatable temperature, valve gate and mold servo control through a single operator interface resulting in a higher performing mold and better part quality



**Hot Runner  
Temperature Control**



**Mold Servo  
Control**

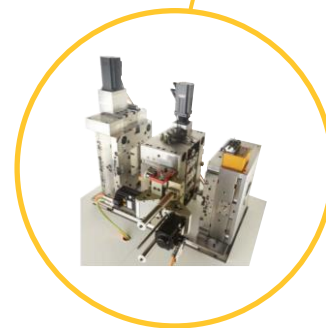

**UltraShot  
Control**



**UltraSync-E  
Control**



**Individual Servo  
Valve Gate Control**



# ACTIVE REASONING TECHNOLOGY 2.0

## FAST, PRECISE, ACCURATE AND REPEATABLE CONTROL

- ✔ ART 2.0 is an all-new second generation control algorithm that further enhances Altanium's best-in-class hot runner temperature control
- ✔ ART 2.0 incorporates advanced autotuning and heat-up strategies reducing tuning time, heat-up time, residence time, and energy usage
- ✔ ART 2.0 also includes Altanium™ base technologies that are integral to control precision, accuracy, and repeatability:
  - **>16.5 million** available control combinations to precisely fit each zone's unique thermal response characteristics
  - **10ms or less** power modulation rate that ensures smooth, consistent power delivery, reducing stress on the heaters
  - **1000 thermocouple samples** per second, safeguarding the integrity of the temperature signal
  - **High level of immunity** to electrical noise further safeguards the integrity of the temperature signal using galvanically isolated T/C input circuits



# INTRODUCING ALTASTART

## INCREASED ENERGY EFFICIENCY, REDUCED RESIDENCE TIME

### GROUNDBREAKING HEATING AUTOMATION

Husky's All-New patent pending hot runner startup strategy!

- Coupled with ART2.0 intelligence, it chooses what zones to heat, when to apply power, and predicts when the hot runner will be ready to process
- Manifolds are heated first using UniStart, and then power is applied to tips, so all zones in the system reach process temperature simultaneously
- Automates the heating strategy recommended by most hot runner manufacturers in the industry



**AltaStart delivers up to 30% less energy usage per startup**



**AltaStart provides up to 77% lower residence time per startup**

# THANK YOU

HUSKY CONTROLLED. HUSKY INFORMATION IS ONLY INTENDED FOR THE RECIPIENT.  
ANY DISSEMINATION TO ANYONE OTHER THAN THE RECIPIENT IS UNAUTHORIZED AND STRICTLY PROHIBITED.