



# JUNIOR CRITTER - SNAIL

Intended user age: 2-5

## PRODUCT INFORMATION

ASTM F1487

Children are invited to climb up and over the shell which features gapped cladding. Climbing holds have been designed on the back, shell and side of the structure. Children can crawl through, sit inside the shell or perch up high on its head. While it is designed for younger children, there's little doubt that older children will also be attracted to this familiar critter.



Maximum height: 6'0"  
Fall height: 6'0"  
Area of Safety Surfacing: 380 ft<sup>2</sup>  
User Capacity: 9

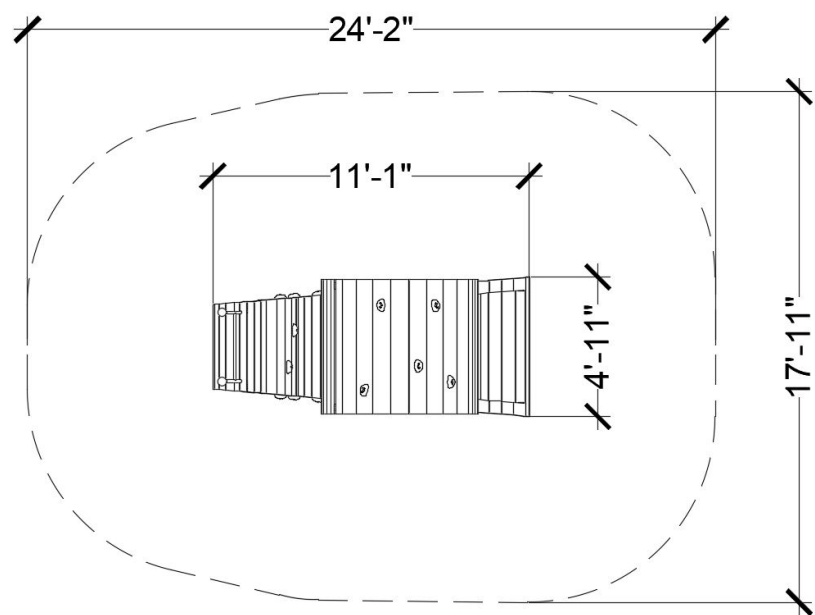

The highest designated play surface and space required are according to ASTM F1487. A buffer is included in the fall zone to account for fabrication and material variations.

Resilient safety surfacing is required within the fall zone of equipment.

If you have questions about the equipment or require changes, please contact Earthscape at 1-877-269-2972.