



LOG TANGLE 2.4

Intended user age: 5-12

PRODUCT INFORMATION

ASTM F1487

Log Tangle 2.4 offers a great combination of low and high challenge nature play with plenty of room for the imagination. It takes balance, agility and perhaps some extra thinking to climb the angled flexform triangles to the higher platform on this natural playground. Log Tangles can be functionally linked with other elements, or can function as a stand-alone structure.

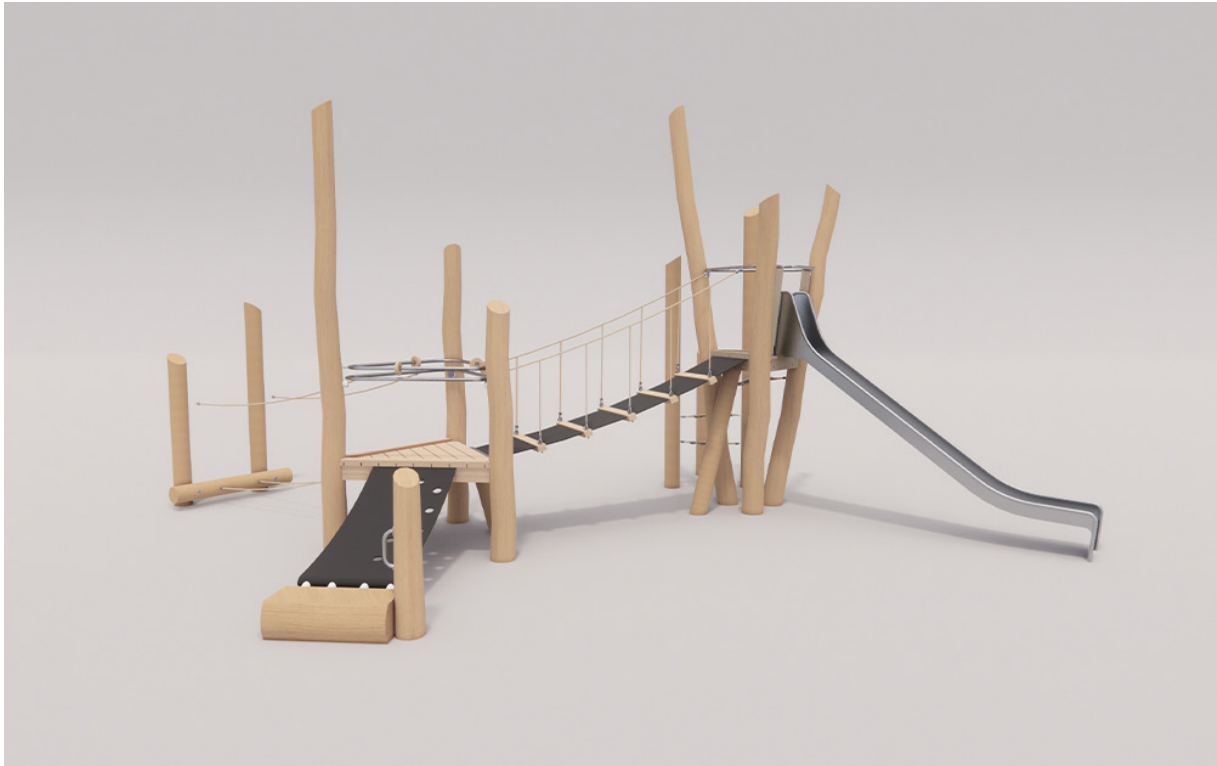

Maximum height: 15'-9"
Maximum fall height: 6'-0"
Area of Safety Surfacing: 1039 ft²

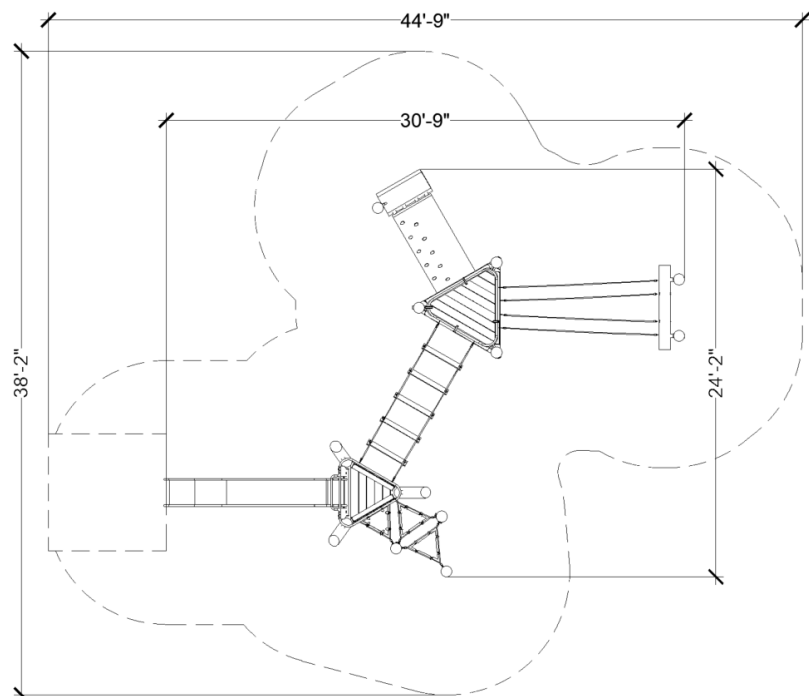

The highest designated play surface and space required are according to ASTM F1487. A buffer is included in the fall zone to account for fabrication and material variations.

Resilient safety surfacing is required within the fall zone of equipment.

If you have questions about the equipment or require changes, please contact Earthscape at 1-877-269-2972.