

Spirent AION

Spirent TestCenter Security Bundle

Overview

Spirent AION is a flexible delivery platform that enables users to achieve improved deployment and provisioning for all their cloud and network testing needs. It is designed to deliver ultimate flexibility in how Spirent TestCenter platforms are purchased and utilized.

The extended platform combines a wealth of industry-leading test solutions with a flexible licensing architecture to support a wide range of next-generation solution-based domain applications.

AION offers a centralized management hub to help leverage software and hardware functionalities across all lab users and locations for a simplified management and decision-making process:

- **Flexible purchasing options** available via subscription, consumption-based, and perpetual plans, with the ability to license different bandwidth, scale, and protocol bundles.
- **Flexible deployment options** offered include cloud-delivery, on-prem, and laptop-hosted licensing services.

Enhanced user serviceability delivers always-on platform services from auto-discovery and inventory management to user and workspace administration, notifications, and log aggregation.

Security Bundle

Security Bundle is a comprehensive test package for Spirent TestCenter that includes multiple different solution that use high class encryption like TLS, OpenSSL in their operations.

Spirent OpenFlow Controller Emulation helps stress-test OpenFlow network switches, providing insight into the throughput and capacity under load. It measures performance, availability, security, and scalability of OpenFlow network devices and end-to-end SDN application scale by defining millions of flows and exercising them with traffic patterns and behavior.

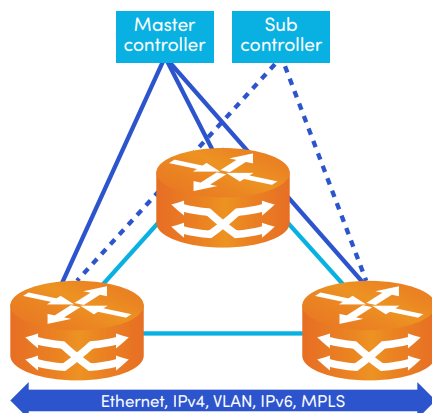

- **SDN Validation**—verify flow scalability and forwarding performance of High-Speed Ethernet in addition to virtual OpenFlow network devices and determine if Software-Defined Networking (SDN) applications can deliver business benefits without degrading the user experience.
- **Increase Productivity**—reduce time-to-test through easy to build complex configurations with wizards at any scale with realistic test environments
- **Cost-Effective Solution**—multiple advanced protocols in a single, affordable package
- **Trusted Partner**—benefit from decades of testing experience with Spirent as your guide through a world of complex testing

Spirent OpenFlow switch emulation helps overcome many testing challenges for OpenFlow Controller testing at scale. Large-scale testing can be difficult because of the need to assemble many switches, activate and interconnect many virtual Switches. OpenFlow switch emulation stress-tests the Controller by emulating various topologies, real Switches with real links. With OpenFlow switch emulation you can quickly and easily setup one to thousands of Switches. Once you create your network, Spirent OpenFlow switch emulation will display all the Flows on all Switches and save them to a file. It can also generate OpenFlow “Packet-Ins” from every Switch to the OpenFlow Controller to validate that it can maintain all its connections to all Switches while processing a high rate of Packet-Ins.

Open vSwitch Database Management Protocol (OVSDB) Emulation based on RFC 7047 allows for configuration and learning of emulated Spirent TestCenter Topologies like OpenFlow Switch Emulation and VXLAN Emulation. Topologies can write configurations and counters to database for reading by most controllers. Spirent TestCenter can view or export to file the OVSDB database. VXLAN VTEPs can now learn using OVSDB vs Multicast or EVPN.

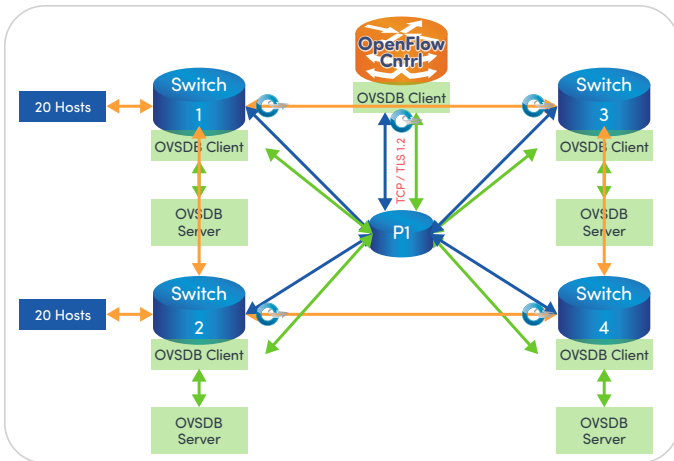

Constrained Application Protocol (CoAP) is a specialized web transfer protocol for use in constrained Internet of Things (IoT) networks. The protocol is designed for machine-to-machine (M2M) applications such as smart energy and building automation.

Spirent TestCenter CoAP/M2M Server Emulation emulates real world smart grids, M2M, automotive telematics and health sector scenarios with CoAP protocol and millions of sensors, and provides solution for end-to-end functional, performance & security testing of IoT and M2M applications.

Internet of Things

Tens of bytes



- Efficient objects
- Efficient web
- Optimized IP access

IEEE 802.1X is an IEEE Standard for port-based Network Access Control (PNAC). It is part of the IEEE 802.1 group of networking protocols. It provides an authentication mechanism to devices wishing to attach to a LAN or WLAN.

The 802.1X defines three roles:

- **Supplicant**–The device that requires accessing the network.
- **Authenticator**–Typically is a managed switch that is physically or logically connected to the supplicant acting as a proxy between the supplicant and the authenticator server.
- **Authentication server**–Typically is a RADIUS server that provides authorization.

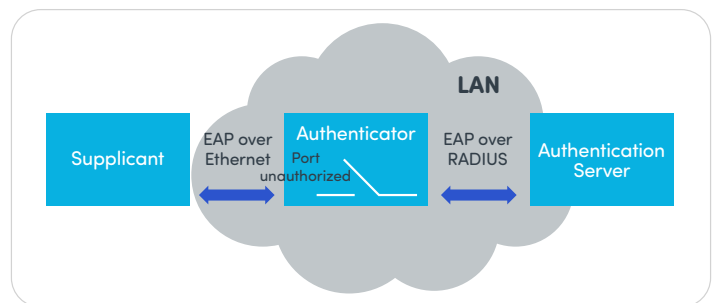

This bundle is an integrated component of Spirent TestCenter and works with other Spirent TestCenter components. The Security Bundle protocols can also be combined with Routing and Switching, Access or Data Center protocols.

Features and Benefits

- With Spirent's OpenFlow Controllers, Flows and Switches, user can test a large switch network with large amounts of flows and traffic analysis on each data path for verification
- Test all aspects of OpenFlow 1.3 network design with high scaled and fully featured controller including features such as: MultiTable, Group Table, Metering, Master & Slave
- Validate all type of Flows including IPv4, IPv6, VLAN, MPLS, ARP with Spirent's comprehensive traffic generation and routing support
- Emulate thousands of OpenFlow Switches at high scale—number of Switches in connected, number of Packet-Ins and test various topologies, Packet-In stability, and Flow validation
- Packet-In Test to validate controller stability over time at high-packet rates from a large number of OpenFlow switches
- OVSDB is integrated with Spirent's OpenFlow Switch Emulation and VXLAN
- Test in a secure network environment under heavy load with Spirent's support of TLS 1.2 secure OpenFlow Channel
- View all Flows on all Switches and save them to a file
- Results for every Switch and Controller
- Emulate real world large-scale smart grids, M2M, automotive telematics and the health sector scenarios with CoAP protocol and millions of sensors
- Support both IPv4 and IPv6 CoAP server emulation
- Support CoAP custom message types
- Support bootstrapping responses without CoAP client requesting
- Support grouping CoAP servers based on call-flows
- Support DTLS encryption of CoAP messages
- Support emulating millions of CoAP servers or IoT sensors
- Support interactive control of CoAP IoT sensor groups which allows users to simulate real network conditions and see results on demand any time during a test without starting and stopping the protocols or traffic
- Support interactive commands to start/stop/flap or age-out, and send periodic update from group of CoAP IoT sensors
- Support advanced command sequencer to send telemetry commands, get Telemetry data, configure the DUT, run entire test and generate pass/fail results
- Emulate 802.1x supplicants
- Support 802.1x MD5, FAST, PEAP, TLS, and TTLS EAP authentication methods
- Support AUTO, GTC, MS-CHAPv2, MD5 inner tunnel EAP methods when FAST, PEAP, and TTLS EAP authentication methods are used
- Support 802.1x supplicant certificates for PEAP, TLS and TTLS EAP authentication methods
- Support configuring 802.1x inner and outer tunnel username and password
- Support setting 802.1x authenticator MAC and the use of 802.1x Port Access Entity (PAE) group MAC
- Support PAC key files for 802.1x FAST EAP authentication method
- Support retransmitting unacknowledged 802.1x messages and retrying failed 802.1x authentication attempts

Technical Specifications

Parameter	Description
SDN	
OpenFlow Controller	<ul style="list-style-type: none"> • Open Networking Foundation OpenFlow v1.0 and v1.3 • Push 1 million + flows to switches • Control up to 1000+ switches with a single controller • Add Flows using traffic already defined, Text Editor, or Graphical Flow Creation • Support for IPv4, IPv6, VLAN, MPLS, VXLAN Flows • Switch Topology Discover using LLDP • Flow Metering Support • Master / Slave support for all controllers • Support for secure channel connection with TLS v1.2
OSE	<ul style="list-style-type: none"> • Support for OpenFlow v1.3 and v1.0 • Connect to multiple Controllers • Configure independent or fixed topologies such as Grid, Linear, or Ring • Topology discovery through LLDP • Support for secure channel connection with TLS v1.2 • View all Flows on all Switches and save them to a file
OVSDB	<ul style="list-style-type: none"> • Interoperability with common SDN Controllers • Integrated with OpenFlow Switch Emulation and VXLAN • Support for multiple controllers • Support for secure channel connection with TLS v1.2 • Read and Export Databases
CoAP	<ul style="list-style-type: none"> • RFC 7252 CoAP server packet encapsulation and decapsulation • RFC 7641 Observing Resources in the Constrained Application Protocol (CoAP) • RFC 7252 CoAP server packet encapsulation and decapsulation • RFC 7641 Observing Resources in the Constrained Application Protocol (CoAP) • RFC 3986 Uniform Resource Identifier (URI) • RFC 6690 Constrained RESTful Environments (CoRE) Link Format • LwM2M Client & Server with full stack implementation • RFC 7250 DTLS Support over UDP for IPv4 • CoAP Message types Supported Bootstrapping, GET, PUT POST and DELETE
802.1X	<ul style="list-style-type: none"> • Emulates 802.1x supplicants • Support MD5, FAST, PEAP (v0 and v1), TLS, and TTLS EAP authentication methods • Support AUTO, GTC, MS-CHAPv2, MD5 inner tunnel EAP methods

Ordering Information

Product Number	Description
AON-PB-SECURITY	Security Export Controlled Bundle

About Spirent Communications

Spirent Communications (LSE: SPT) is a global leader with deep expertise and decades of experience in testing, assurance, analytics and security, serving developers, service providers, and enterprise networks. We help bring clarity to increasingly complex technological and business challenges. Spirent's customers have made a promise to their customers to deliver superior performance. Spirent assures that those promises are fulfilled. For more information visit: www.spirent.com

Americas 1-800-SPIRENT

+1-800-774-7368 | sales@spirent.com

Europe and the Middle East

+44 (0) 1293 767979 | emeainfo@spirent.com

Asia and the Pacific

+86-10-8518-2539 | salesasia@spirent.com