

Spirent Attero-100G

5G Fronthaul Network Impairment Testing

Product highlights for 5G Fronthaul

- 25GbE and 10GbE Fronthaul with SyncE pass-thru.
- External clock inputs.
- eCPRI and RoE (IEEE 1914.3) traffic filtering.
- Extensive traffic filter with customizable ranges.
- Create filters on captured pcap file.
- 2 to 16 profile options available.
- Full line-rate delay: 256ms at 100GbE, 640ms at 40GbE, 1024ms at 25GbE, 2560ms at 10GbE.
- Packet jitter with 400ms jitter range.
- 100GbE and 40GbE optical interfaces also available.



Spirent Attero-100G

What is Fronthaul?

To understand the concept of the “fronthaul”, it’s useful to first understand what the “backhaul” is. “Backhaul” was a term originally coined by the trucking industry, and referred to a truck carrying a load from a remote location back to a central distribution centre. The term was then applied in all contexts to refer to links connecting a remote site to a central site.

In mobile telecoms, “backhaul” is the link from the radio basestation back into the core network i.e. hauling the data back from the basestation to the core. These links are bi-directional so they also carry data from the core out to the basestation.

Traditionally, a basestation sits in a cabinet and is connected by a co-axial cable running up the tower to the antenna. This has issues with power loss of the coaxial cable along with potential interference and space issues.

So it was proposed to site the actual RF transceiver at the top of the tower beside the antenna, and connect the transceiver via optical fibre to the basestation below. This fibre connection between the basestation and the RF transceiver became known as “fronthaul” as shown below:

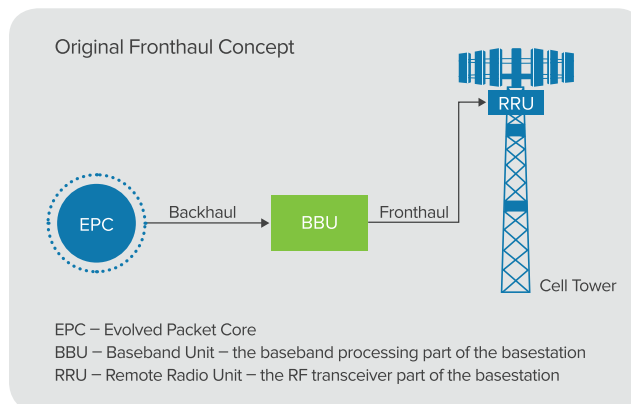

Baseband Hotel and C-RAN Architecture

The protocol for the fronthaul interface was specified in the Common Public Radio Interface (CPRI), produced by an industry consortium consisting of Alcatel-Lucent, Ericsson, Huawei, NEC and Nokia. Since CPRI is carried over a fibre connection, it was concluded that the fibre could be made considerably longer than the height of a tower, freeing the mobile operator from having to place the baseband unit (BBU) at the antenna location. This is particularly attractive for dense urban locations where there might be several antennas within a small area.

Spirent Attero-100G

5G Fronthaul Network Impairment Testing

Deployments consisting of several BBUs were co-located at a central site known as a “baseband hotel” and connected to the Remote Radio Units (RRUs) using CPRI over dark fibre. This deployment style became known as Centralised Radio Access Network (C-RAN).

C-RAN simplified the backhaul network because several BBUs could be co-located together and served by a common, high-bandwidth connection. It also simplified synchronisation since all the BBUs could be served by the same time and frequency reference, guaranteeing accurate synchronisation.

Provided the latency of the fibre connection to the RRUs was known accurately, the BBUs could schedule transmission of the radio frames such that at each antenna, the radio frames would align with those from other antennas. Synchronisation then becomes more of a latency management issue rather than a distributed network synchronisation problem.

The downside of the C-RAN architecture was that the fronthaul connections required dark fibre. This is costly to install and prevents sharing of fibres. Furthermore, the CPRI protocols limit the maximum distance between the BBU and RRU to a few kilometres, which reduces the economies of scale provided by the baseband hotel concept. Therefore, the original C-RAN concept didn't see much take-up for LTE deployments.

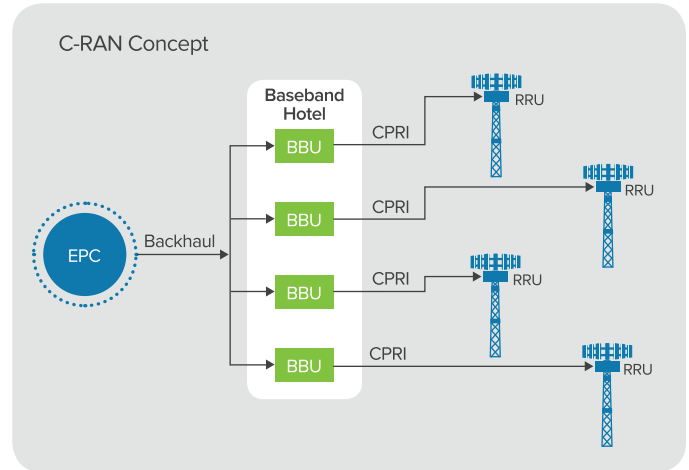

eCPRI and 5G functional split

The dark fibre used by CPRI connections is not only expensive to install, it is also an inefficient use of fibre as it's not fully utilised by a CPRI connection. Some proposals were made to carry CPRI over Wavelength Division Multiplexing (WDM) to enable sharing of fibres between closely sited RRUs. However, the next major step in the evolution of the fronthaul was to consider whether the CPRI protocol could be transported across a shared network such as Ethernet.

The CPRI consortium recently published a new specification called eCPRI that defines how to carry radio signals over a packet network. The underlying networks are not defined, but can include IP/UDP and/or Ethernet. The consortium does not specify what the “e” stands for; it could be for Ethernet (but eCPRI also works over IP), Evolved (a term used to denote 4G over 3G) or, perhaps, Enhanced.

The IEEE are also in the process of creating an open standard for the same thing, designated IEEE1914. This is split into two parts: the radio over packet protocol (IEEE1914.3), and the requirements on the underlying transport network (IEEE1914.1). The main feature of both of these is that the functions of the basestation are split into three parts - the CU (Centralised Unit), the DU (Distributed Unit) and the RRU, as shown opposite:

One reason for this is that carrying a radio signal across a packet network is very inefficient, especially for 5G where the data rates are particularly high. The RRU connection may require a data rate of 25Gb/s or higher, therefore the final link to each RRU is kept as short as possible by deploying a small DU in the network close to the RRUs. The “middlehaul” connection between CU and DU can be lower bandwidth because carrying the intermediate data is more efficient than the encoded radio signal.

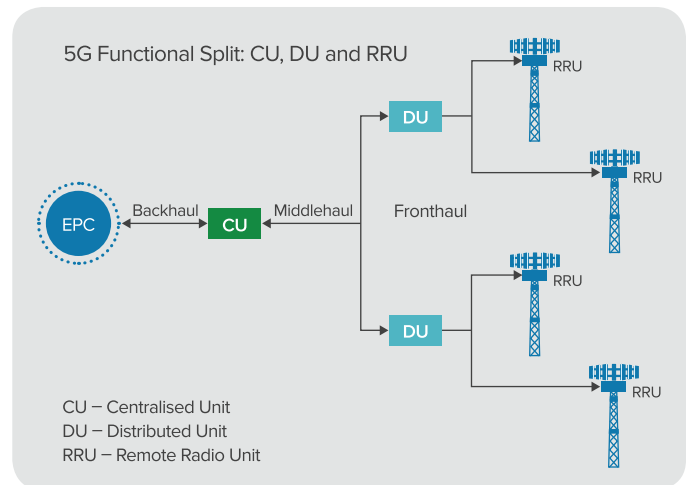

A second reason is that some functions are very latency sensitive, limiting the length of the connection to a few kilometres as with the original CPRI interface. If those functions are located in the DU, the less latency sensitive portions of the basestation function can be located further back in the network. This last piece enables the transition from Centralised RAN to Cloud RAN where the CUs can be located almost anywhere in the network, not just in a localised “baseband hotel”.

Synchronization Methods in Fronthaul

Time and frequency distribution in the network are separated into two independent planes. Enhanced Synchronous Ethernet (SyncE) is used at the physical layer to distribute the frequency and Precision Time Protocol (PTP) at the packet layer to distribute the time and phase. These capabilities have long been present in the backhaul - and with the movement towards the use of Ethernet in the fronthaul, are now being extended to cover that area as well.

Network Emulation and SyncE

As stated above, SyncE is utilised in the fronthaul, that is, the connection between the BBU and RRU or RRH. (The BBU is simply the CU and DU, shown in the previous Functional Split diagram, combined into one functional block for simplicity.) It's vital that synchronisation is maintained between the BBU and RRU/RRH. The network emulator used to impair the network must operate at exactly the same line rate as the fronthaul connection in order to emulate correctly. In other words, it must be synchronised to the line rate and must not break the synchronisation path between BBU and RRU/RRH or sync/data will be lost.

Very few network emulators were designed with SyncE in mind, and as such, will be unable to pass the SyncE clock from one port to another, thus breaking the synchronisation path. However, the Spirent Attero-100G was designed to support both SyncE pass-thru and synchronisation to an external reference clock.

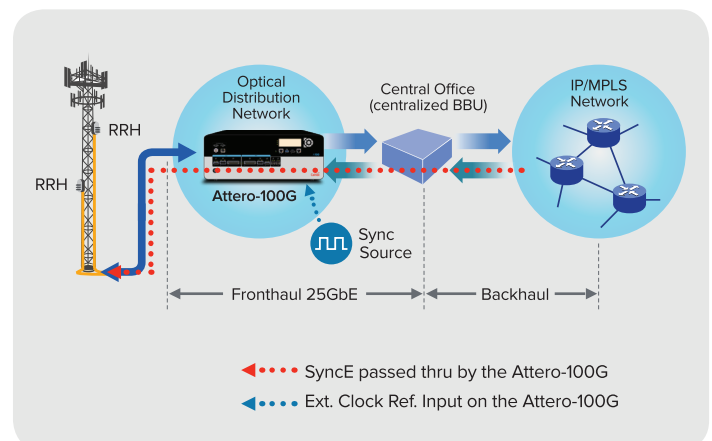

As well as supporting SyncE pass-thru and/or external clock references, the network emulator needs to support the 25GbE and 10GbE interfaces that fronthaul networks are carried over today. The diagram above shows how the Spirent Attero-100G should be inserted into the fronthaul path. This is a simplistic diagram showing the emulator connected between the BBU and the RRU/RRH. The reason for adding network emulation is that it's important to test the fronthaul network and the associated fronthaul network equipment in the presence of real network conditions, for example

1. What happens when network delay is increased?
2. What happens when packet loss is introduced and re-transmission occurs or data is lost?
3. What happens when packet jitter is added to the network?

Network Emulation and eCPRI

As mentioned earlier, the eCPRI specification defines how to carry radio signals over a packet network carrying radio messages between the BBU and the RRU/RRH and handling all of the Traffic and Control & Management. eCPRI is a higher layer service and is depicted opposite being carried over UDP and IP. It is also possible for it to be carried directly over Ethernet.

The structure of the eCPRI User Plane messages common Header format is shown below. Each message has a 4 byte eCPRI common header (bytes 0 to 3) followed by a variable length eCPRI payload.

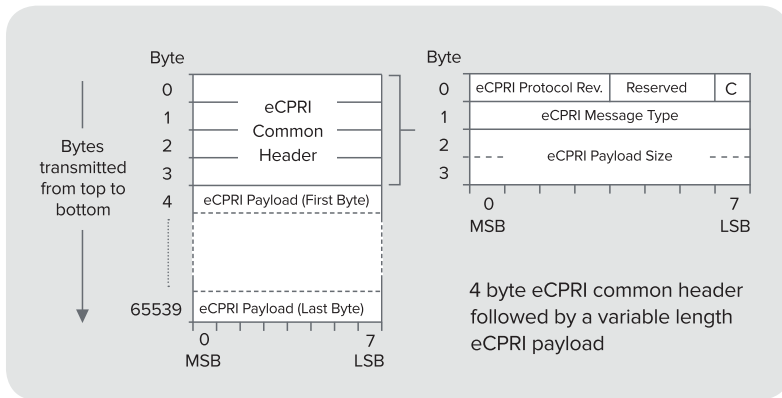

Message Type #1: Bit Sequence used to transfer user data in the form of bit sequences between PHY processing elements split between eCPRI nodes.

Message Type #2: Real-Time Control Data used to transfer vendor specific real-time control messages between PHY processing elements eCPRI node (eREC and eRE). This message addresses the need to exchange various types of control information associated with user data (in form of IQ samples, bit sequence, etc.) between eCPRI nodes in real-time for control/configuration/measurement.

Message Type #3: Generic Data Transfer used to transfer user plane data or related control between eCPRI nodes (eREC and eRE) providing extended data synchronisation support for generic data transfers.

Message Type #4: Remote Memory Access allows reading or writing from/to a specific memory address on the opposite eCPRI node. The service is symmetric i.e. any side of the interface can initiate the service.

Message Type #5: One-way Delay Measurement is used to estimate the one-way delay between two eCPRI-ports in one direction. The measurement can be performed with or without a Follow_Up message (1-step and 2-step versions). The decision of which version to use is vendor specific.

Message Type #6: Remote Reset is used when one eCPRI node requests reset of another node. A remote reset request by an eREC triggers a reset of an eRE.

Message Type #7: Event Indication is used when either side of the protocol indicates to the other end that an event has occurred. An event is either a raised or ceased fault or a notification. Transient faults are indicated with a Notification.

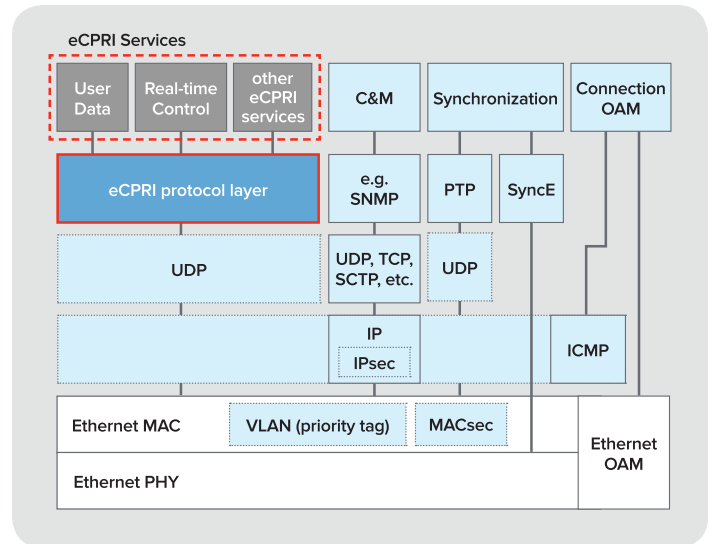

C (the LSB in byte 0) is the eCPRI messages concatenation indicator. A value of "1" indicates that another eCPRI message follows this one within the eCPRI PDU. A value of "0" indicates that the eCPRI message is the last one inside the eCPRI PDU.

Message Type #0: IQData used to transfer time domain or frequency domain IQ sample between PHY processing elements split between eCPRI nodes.

In order to understand how eCPRI behaves in a real fronthaul network, and to be able to see the effect of network impairments on specific eCPRI message types, the user must be able to filter on a particular eCPRI message type and then add network impairments to the eCPRI message such as packet loss, delay and also jitter.

The screenshot below shows the eCPRI filter builder within the Spirent Attero-100G and the different eCPRI message types which the user can filter on:

Message Type #	Name
0	IQ Data
1	Bit Sequence
2	Real-time Control Data
3	Generic Data Transfer
4	Remote Memory Access
5	One-way Delay Measurement
6	Remote Reset
7	Event Indication
8 – 63	Reserved
64 – 255	Vendor Specific

Network Emulation and Radio over Ethernet

A competing method for transferring CPRI data over the fronthaul network is Radio over Ethernet (RoE). This is defined in IEEE1914.3. It enables transport of structure-aware mappers and structure-agnostic mappers for CPRI/OBSAI (Open Base Station Architecture Initiative) and other data formats as well as native I and Q data over Ethernet. The IEEE 1914.3 standard supports:

- The encapsulation of digitized radio. In-phase Quadrature (IQ) payload, possible vendor specific flows and control data channels/flows into an encapsulating Ethernet frame payload field.
- The header format for structure-aware and structure-agnostic encapsulation of existing digitized radio transport frames. The structure-aware encapsulation has detailed knowledge of the encapsulated digitized radio transport format content. The structure-agnostic encapsulation is only a container for the encapsulated digitized radio transport frames.
- A structure-aware mapper for CPRI frames and payloads to/from Ethernet encapsulated frames. The structure-agnostic encapsulation is not restricted to CPRI.

RoE (IEEE 1914.3) Common Header Format

The table below depicts the first header bytes in the RoE frame that is common to RoE control packets. The RoE subtype values or Packet Types are described in more detail in the following RoE (IEEE 1914.3) Packet Types table.

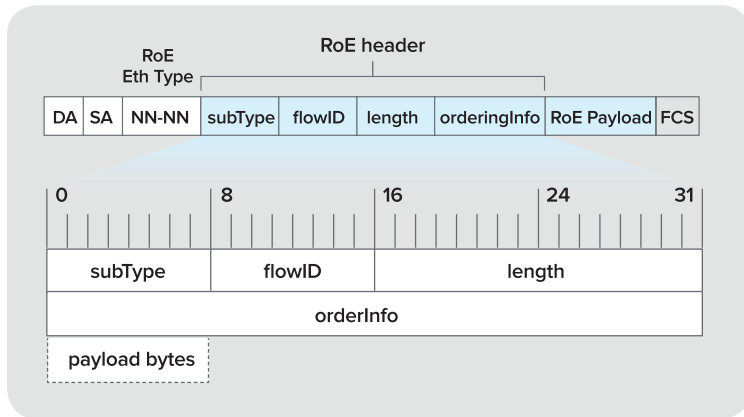

where:

- subType** – **Packet type**
Control, structure agnostic, structure aware, native time domain, native frequency domain and slow C&M packet types are defined
- flowID** – Flows allow SA/DA pairs to distinguish connections
- length** – Payload size
- orderingInfo** – Sequence number or timestamp
- Payload** – The IQ data/control information

The Spirent Attero-100G can be used for RoE in a similar fashion to eCPRI (covered in the previous section). In order to understand how RoE behaves in a real fronthaul network and to be able to see the effect of network impairments on specific RoE message types, the user must be able to filter on a particular RoE message type and then add network impairments such as delay, packet loss and jitter. For example, the Spirent Attero-100G can be used to stress the limit of operation of RoE equipment by adding delay up to, and beyond, the 100µs limit.

The screenshot below shows the RoE filter builder within the Spirent Attero-100G network emulator and a drop-down selection of the different RoE message types which you can filter on:

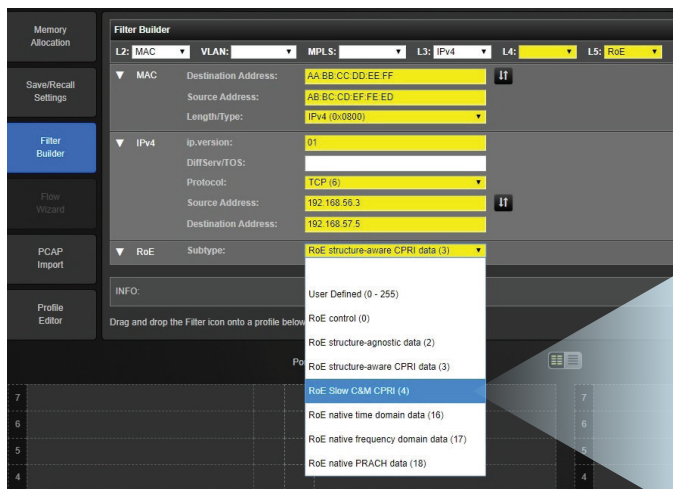

RoE (IEEE 1914.3) Packet Types

BINARY VALUE	FUNCTION	DESCRIPTION
0000 0000b	RoE Control sub type	RoE message that contains control or management information.
0000 0001b	Reserved 1	Reserved for future use by IEEE Std 1914.3. Reserved subType values shall not be transmitted. RoE messages with Reserved subTypes shall be ignored on receipt.
0000 0010b	RoE Structure-agnostic data sub type	Data payload packet with RoE common frame header and structure-agnostic payload.
0000 0011b	RoE Structure-aware CPRI data sub type	Data payload packet with RoE common frame header and structure-aware CPRI I/Q data.
0000 0100b	RoE Slow C&M CPRI sub type	C&M payload packet with RoE common frame header and structure-aware CPRI Slow C&M payload.
0000 0101b - 0000 1111b	Reserved2	Reserved for future use by IEEE Std 1914.3. Reserved subType values shall not be transmitted. RoE messages with Reserved subTypes shall be ignored on receipt.
0001 0000b	RoE Native time domain data sub type	Time domain data payload packet with RoE common frame header.
0001 0001b	RoE Native frequency domain data sub type	Frequency domain data payload packet with RoE common frame header.
0001 0010b	RoE Native PRACH data sub type	PRACH IQ data payload with common frame header.
0001 0011b - 0111 1111b	Reserved3	Reserved for future use by IEEE Std 1914.3. Reserved subType values shall not be transmitted. RoE messages with Reserved subTypes shall be ignored on receipt.
1000 0000b - 1011 1111b	Mapped subTypes	Companies and/or organizations owning an OUI or CID can use this subType range for their own subTypes and payload structures as defined in subclause 5.3.4.
1100 0000b - 1111 1011b	Reserved4	Reserved for future use by IEEE Std 1914.3. Reserved subType values shall not be transmitted. RoE messages with Reserved subTypes shall be ignored on receipt.
1111 1100b - 1111 1111b	Experimental	Reserved for experimental types. The nature and purpose of an experimental subType cannot be known in advance, thus the structure after the common RoE header is defined as opaque. Entities implementing the subType can interpret the message according to their implementation.

Spirent **Attero-100G**

5G Fronthaul Network Impairment Testing

This discussion of fronthaul networking would not be complete without mentioning the 802.1CM standard that has been published by the IEEE's Time-Sensitive Networking (TSN) Task Group. It was developed through a collaborative effort between the CPRI Cooperation and IEEE 802.1. IEEE Std 802.1CM specifies two TSN Profiles for Fronthaul - one for eCPRI and one for CPRI.

Summary

The fibre connection between the basestation and the RF transceiver is known as "fronthaul". The legacy protocol for the fronthaul interface was specified in the Common Public Radio Interface (CPRI). There are two competing methods for extending CPRI for use over Ethernets - eCPRI and Radio over Ethernet (RoE) as defined in IEEE 1914.3

SyncE (standardised by ITU-T G.8262) is utilised in the fronthaul to distribute frequency. As a result, any network emulator that is used to impair the fronthaul network must support SyncE pass-thru or be able to lock to an external clock reference. In addition, the network emulator needs to be able to support the 25GbE and 10GbE interfaces that fronthaul networks are carried over today.

The Spirent Attero-100G was designed with SyncE in mind and supports both SyncE pass-thru and synchronisation to external clock references, as well as the 25GbE and 10GbE interfaces that fronthaul requires. The Spirent Attero-100G can also filter on, and impair, specific eCPRI and RoE message types thereby helping engineers understand how eCPRI and RoE behave in a real fronthaul network.

Furthermore, time-sensitive fronthaul networks have a one-way latency requirement of about 100µs. New technologies, such as eCPRI and RoE, are needed to enhance best effort Ethernet to make it deterministic and time bound. The Spirent Attero-100G can be used to add delay to specific fronthaul packet types and stress the limit of operation of eCPRI and RoE equipment and networks.

About Spirent Communications

Spirent Communications (LSE: SPT) is a global leader with deep expertise and decades of experience in testing, assurance, analytics and security, serving developers, service providers, and enterprise networks.

We help bring clarity to increasingly complex technological and business challenges.

Spirent's customers have made a promise to their customers to deliver superior performance. Spirent assures that those promises are fulfilled.

For more information, visit:
www.spirent.com

Contact Us

For more information, call your Spirent sales representative or visit us on the web at www.spirent.com/ContactSpirent.

www.spirent.com

Americas 1-800-SPIRENT
+1-800-774-7368 | sales@spirent.com

Europe and the Middle East
+44 (0) 1293 767979 | emeainfo@spirent.com

Asia and the Pacific
+86-10-8518-2539 | salesasia@spirent.com