



GSS7765

Interference Simulation System

Datasheet With Product Specification

PROPRIETARY INFORMATION

THE INFORMATION CONTAINED IN THIS DOCUMENT IS THE PROPERTY OF SPIRENT COMMUNICATIONS PLC. EXCEPT AS SPECIFICALLY AUTHORISED IN WRITING BY SPIRENT COMMUNICATIONS PLC, THE HOLDER OF THIS DOCUMENT SHALL KEEP ALL INFORMATION CONTAINED HEREIN CONFIDENTIAL AND SHALL PROTECT SAME IN WHOLE OR IN PART FROM DISCLOSURE AND DISSEMINATION TO ALL THIRD PARTIES TO THE SAME DEGREE IT PROTECTS ITS OWN CONFIDENTIAL INFORMATION.

© COPYRIGHT SPIRENT COMMUNICATIONS PLC 2013 - 2020.

Spirent GSS7765 Interference Simulation System

TABLE OF CONTENTS

| | |
|--|-----------|
| General | 4 |
| Scope & applicability | 4 |
| Introduction | 4 |
| General | 4 |
| Compatible GNSS simulator platforms | 6 |
| Operating Mode | 6 |
| Fixed Level Mode | 6 |
| Modelled Mode | 7 |
| Technical performance | 8 |
| CW interference | 8 |
| Signal Type..... | 8 |
| Frequency | 8 |
| Spectral purity | 8 |
| Swept CW interference | 8 |
| Signal Type..... | 8 |
| Stepped CW interference | 8 |
| Signal Type..... | 8 |
| AM interference | 9 |
| FM interference | 9 |
| Noise interference | 9 |
| Pulse modulation | 9 |
| RF level (per source) From ICU Output | 10 |
| External frequency standards | 10 |
| Performance Extensions | 10 |
| Instrument Security Feature | 10 |
| Operational performance | 11 |
| Physical form | 11 |
| Environmental | 11 |

| | |
|---|-----------|
| Deliverables | 12 |
| Signal generator procurement details | 12 |
| Manufacturer | 12 |
| Signal generator description | 12 |
| Product code | 12 |
| Options | 12 |
| Software licence key (required) | 13 |

Spirent GSS7765 Interference Simulation System

General

Scope & applicability

The information contained in this document shall be the sole source of technical performance specification for contractual purposes in relation to the **GSS7765 Interference Simulation System** for the Spirent range of GNSS RF Constellation Simulators.

Introduction

General

The GSS7765 Interference Simulation System (ISS) is a solution that fully integrates commercial-off-the-shelf (COTS) signal generators as interference sources with Spirent SimGEN-based satellite navigation simulators, such as the GSS9000, GSS7000 and GSS6700. **Figure 1** shows a typical solution with the GSS9000:



Figure 1 GSS7765 shown with GSS9000

The ISS is designed for testing interference immunity of GNSS devices in a simulated environment. Currently, up to 4 interference signal generators may be controlled via Ethernet from the simulator's SimGEN host controller. The interference signal is defined, along with all the other scenario parameters, from within the SimGEN for Windows GUI environment.

The **GSS7765** supports CW, swept CW, stepped CW, pulsed CW, AM and FM. The unit can also supply band-limited white Gaussian noise with a maximum bandwidth of up to 48 MHz.

Each interference source can operate independently using either fixed or modelled signal power level. It can be programmed to have any of the interference types and characteristics described in the **Technical performance** Section of this specification.

Each signal generator produces one signal. This means that two sources would be required to generate noise at GPS L1 and L2 frequencies simultaneously, for example.

The RF outputs are combined with the GNSS signals in the GSS8366 Interference Combiner Unit (ICU), which is a calibrated unit, manufactured by Spirent. The ICU has two outputs, to support differential systems. Each output is the combination of up to four Interferer inputs and one GNSS input. The four-way combiner in the ICU may be optionally bypassed when only one source is required, reducing the insertion loss and increasing the Interference/Signal ratio available. For simulation systems with more than two antenna outputs, ICU units can be combined as necessary.

The ISS has a flexible architecture and supports a wide range of options, from single-source/single-antenna to complex interference for multiple antennas.

The ISS is controlled via the same instance of SimGEN as the GNSS simulator. Alternatively, the user may directly control ISS sources independently either via their front panel controls or from a separate controller using their native command set.

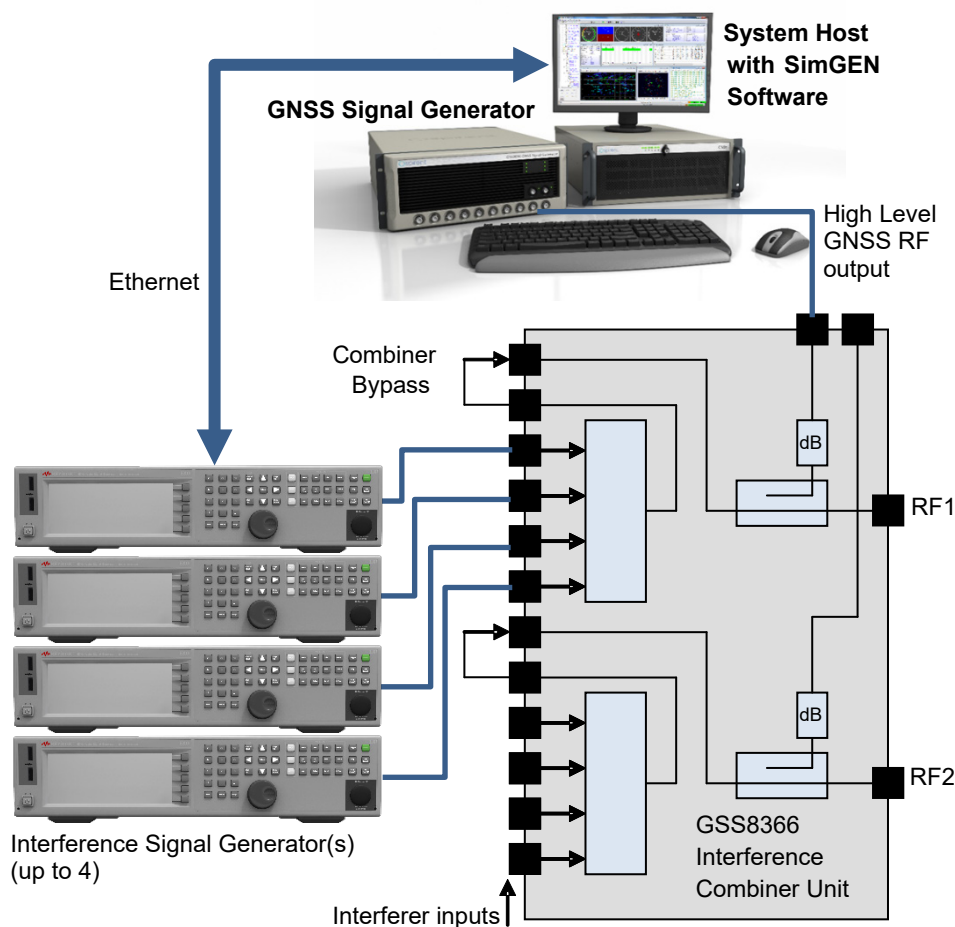

Figure 2 4-generator GSS7765 system GSS9000

Spirent GSS7765 Interference Simulation System

Compatible GNSS simulator platforms

The GSS7765 is compatible and fully qualified with the Spirent GNSS simulator platforms listed in the table below

| Model | Description |
|---------|----------------|
| GSS7000 | GNSS Simulator |
| GSS9000 | GNSS Simulator |

The GSS7765 is compatible with the Spirent GNSS simulator platforms listed in the below however, these are obsolete platforms and ongoing release testing/qualification is no longer carried out.

| Model | Description |
|-----------------|--|
| GSS6560 | GPS/SBAS Simulator (L1) |
| GSS6700 | GNSS Simulator |
| GSS8000 | GNSS Simulator |
| GSS7700 | GPS/SBAS Simulator (L1, L2, L5) |
| GSS7800 | Galileo Simulator (E1, E5, E6) |
| GSS7900 | GPS + Galileo simulator |
| GSS4760 | GPS/SBAS Simulator (L1, L2) |
| GSS4750 | GPS Simulator L5 |
| GSS4780 | GLONASS Simulator |
| STR4790/GSS7790 | GPS/SBAS Simulator (L1, L2) Multi-Output |

Operating Mode

GSS7765 is controlled via SimGEN to provide the following functionality for each interference channel:

- Interference type and characteristics (e.g. CW or FM, Centre Frequency, etc.)
- Fixed Interferer Position (Latitude, Longitude, Altitude)
- Interferer Initial or base RF Power Level. (The Interferer is assumed to transmit from an omnidirectional antenna).
- Programmable Interferer 'ON' and 'OFF' periods

The Interference type and/or characteristics may be changed during the scenario using a file containing a time ordered script of events. The output level is further controlled by the specified operating mode, FIXED or MODELLED. The operating mode can change as required during the scenario. Both of the operating modes are also compatible with operation from the SimREMOTE remote control option.

Fixed Level Mode

- In fixed level mode the interferer power is set by an explicit user command and does not change. It is the default mode where a time-ordered script file controls the RF power level.
- The power level is maintained until commanded to change by the script and is independent of any other scenario elements such as simulated vehicle motion and modelling of the receiver's reception antenna gain pattern.

Modelled Mode

- The modelled mode simulates interference power level variation due to realistic relative vehicle motion with respect to the fixed interference source locations.
- The power level presented by the interference source varies in accordance with an inverse-square-law characteristic related to the range between the simulated host vehicle and the Interferer.
- The power level is also varied to simulate the effects of the receiver's reception antenna gain pattern.
- In Modelled mode scripts are used to set initial power levels and Interferer types. In this mode, the power level is updated at maximum of **100Hz** Signal Iteration Rate (SIR) via Ethernet connection and 10Hz via GPIB connection.

Spirent GSS7765 Interference Simulation System

Technical performance

Each interference source of the ISG is independently capable of generating signals with the following characteristics:

CW interference

Signal Type

A Continuous Wave or unmodulated carrier.

CW signals from multiple generators can be selected to be coherent or non-coherent via the SimGEN GUI. Note: For coherent sources the interference generators require a common, external 10MHz reference.

Frequency

| | |
|----------------------|---|
| Frequency Range | 0.5 to 2 GHz |
| Frequency Resolution | 0.01 Hz |
| Frequency Stability | <±1ppm/yr, ±1 ppm typical over 0 to +55°C |

Spectral purity

| | |
|----------------------------|----------|
| Harmonics | <-30 dBc |
| Non-harmonics | <-66 dBc |
| Sub-harmonics ¹ | <-82 dBc |

Swept CW interference

Signal Type

The user defines the centre frequency and frequency span plus a sweep rate using the FM type.

| | |
|---|--|
| Carrier: | as CW |
| Frequency Span: | to 20MHz (1.5 to 2 GHz band) to 10MHz (0.75 to <1.5 GHz band) to 5MHz (0.5 to <0.75 GHz) |
| Sweep type (cyclic): | Sine |
| Sweep rate: | 0.1 Hz to 2 MHz |
| Additional frequency error ² | < ±0.2% of set deviation + 2Hz |

Stepped CW interference

Signal Type

Generated as a sequence of CW frequency steps. The user defines the start and stop frequencies, together with the number of steps and dwell time. The overall pattern is that of a saw-tooth ramp.

| | |
|----------------------------------|----------------|
| Carrier: | as CW |
| Number of frequency step points: | 2 to 65535 |
| Dwell time at each step: | 100 µs to 100s |

¹ CW mode

² The following comment from the Agilent documentation applies "Specification valid for temperature changes of less than ±5 °C since last DC FM calibration".

AM interference

| | |
|-------------------------|---|
| Carrier: | as CW |
| AM Depth: | 0 to 90% in 0.1% steps (nominal) ³ |
| Distortion (1kHz rate): | <0.2%, typical at 1kHz rate |

Modulating signal:

| | |
|---------------------|--------------------------------------|
| Waveforms: | sine, square, ramp and triangle |
| Rate: | 0.1 Hz to 10 kHz (typical) |
| Resolution: | 0.1 Hz |
| Frequency accuracy: | same as RF reference source, typical |

FM interference

| | |
|----------------------------|---|
| Carrier: | as CW |
| Maximum deviation: | 20MHz (1.5 to 2.0 GHz band) 10MHz (0.75 to <1.5 GHz band) 5MHz (0.5 to <0.75 GHz) |
| Resolution: | 0.1% of deviation or 1Hz, whichever is greater (nominal) |
| Distortion: | <0.4% ⁴ |
| Additional frequency error | <±0.2% of set deviation + 2Hz ⁵ |

Modulating signal:

| | |
|---------------------|---|
| Waveforms: | sine, square, ramp and triangle. |
| Rate | 5 Hz to 2 MHz (sine) 0.1 Hz to 10 kHz (square, ramp, triangle) |
| Resolution | 0.1 Hz |
| Frequency accuracy: | same as RF reference source, typical |

Noise interference

| | |
|--------------------------|----------------|
| Carrier: | as CW |
| Bandwidth (3dB): | 1 Hz to 48 MHz |
| Resolution on bandwidth: | 0.1Hz |

Pulse modulation

Pulse may only be applied to CW, Stepped CW, and Noise Interference types.

Pulse:

| | |
|-------------------|--|
| Period: | 2.01μs to 42s |
| Width: | 2μs to pulse period -10ns (typ), resolution 10ns |
| On/Off Ratio: | >80dB |
| Rise/Fall Time: | <10ns (typ) |
| Square wave rate: | 0.1Hz to 10 MHz, resolution 0.1 Hz (nom) |

³ Peak of AM envelope must not exceed the maximum available power

⁴ The following comment from the Agilent documentation applies "1kHz rate with deviation 100kHz for carrier >1.5GHz or deviation 50kHz for carrier 0.75 to <1.5GHz"

⁵ The following comment from the Agilent documentation applies "Specification valid for temperature changes of less than ±5 °C since last DC FM calibration"

Spirent GSS7765 Interference Simulation System

RF level (per source) From ICU Output

| | |
|--|-------------|
| GPS signal level (L1 P, nominal, per SV) | -163.0 dBW |
| GPS signal level control (about nominal) | ±20 dB |
| GPS signal level accuracy | ±1.0 dB RSS |

I/S ratio relative to any GPS L1 P-code signal at nominal GPS signal level
 - All modes -1 to +136 dB

Interference level expressed as absolute power⁶
 - All modes -164 to -27 dBW

Interference accuracy (CW)⁷

| | |
|------------------------|-------------|
| - I/S 63 to 136 dB | ±1.0 dB RSS |
| - I/S 16 to 63 dB ±1.1 | dB RSS |
| - I/S -1 to 16 dB ±1.6 | dB RSS |

Interference level resolution 0.02 dB (nom)

Increase all Interferer ICU output levels by approximately 7 dB if the option to bypass the four-way combiners in the ICU is exercised.

External frequency standards

It is possible to lock the Interference signal generator(s) to an external 10 MHz reference frequency.

Each generator provides a 10MHz output that may be used as a reference source for other elements of the simulation system.

Performance Extensions

Baseline performance can be enhanced to offer custom waveform modulations and FIR (finite impulse response) filters for use with the GSS7765, note specific options exist to facilitate these only for N5172B instruments.

The specific 'custom' modulation type is based on Keysight Technologies binary waveform format and its associated parameters will be configurable during the simulation run using the Positioning Application GUI. FIR filter coefficients are loadable in ASCII format as defined by Keysight Technologies and stored alongside the binary waveforms.

In order to realise these capabilities not only are there specific options required on the given GSS7765 along with a system specific licence within PosApp.

Instrument Security Feature

Optionally (for N5172B) based systems there is an instrument security feature including removable memory to allow for removal from secure environments.

⁶ Specified maximum interferer level in ambient +20 to +30 °C. Typically the maximum level reduces by 0.2 dB/°C outside of this range.

⁷ These values assume ISS uncertainty between 20 and 30 °C. For temperatures outside of this range the accuracy degrades by 0.01 dB/°C

Operational performance

Physical form

The GSS7765 Interference Simulation System comprises a Spirent ICU single chassis together with a number of commercial signal generator chassis. All units are rack-mountable in the industry standard 19-inch format.

Dimensions (H x W x D)

COTS generators: 88 H⁸ x 458 W x 508 L mm (3.46"x18"x20")
Weight: ≤ 15.9 kg (35 lb.)

ICU: 89 H x 426 W x 200 L mm (3.5"x16.8"x7.9")
Weight: ≤ 4 kg (9 lb.)

Environmental

The equipment is suitable for operation only in a typical office or laboratory environment.

Operating Conditions

Temperature: 0°C to +55°C

The equipment employs forced-air cooling.

Relative Humidity: 75% max

Mechanical: Not exposed to vibration, shock or bump.

Storage Conditions: -40°C to +70°C

Power Requirements (each generator):

- 100 to 120 VAC, 50 to 60 Hz
- 220 to 240 VAC, 50 to 60 Hz
- 300 W maximum

EMC:

Complies with European EMC Directive 2004/108/EC

- IEC/EN 61326
- CISPR Pub 11 Group 1, class A
- AS/NZS CISPR 11
- ICES/NMB-001

Safety:

Complies with European Low Voltage Directive 2006/95/EEC

- IEC/EN 61010-1
- Canada: CSA C22.2 No. 61010-1
- USA: UL 61010-1
- German Acoustic statement

⁸ H does not include the removable feet. With feet removed the unit can be accommodated in 2U.

Spirent GSS7765 Interference Simulation System

Deliverables

| ITEM | QTY | DESCRIPTION | COMMENT |
|------|---------|---|--|
| 1 | 1 | GSS8366 Interference Combiner Unit | One required per system |
| 2 | 1 set | Interconnection cables <ul style="list-style-type: none"> • One Ethernet Cable per generator (2m) • One RF Cable per generator (1.5m RG142 N to N)) • One GNSS RF Cable (1.5m RG142 N to N)) • One synchronisation cable per generator (1m BNC to BNC) • Two link cables (15cm BNC to BNC) | appropriate for target system |
| 3 | up to 4 | Digital Signal Generator | Can be customer furnished ⁹ |
| 4 | 1 | Printed User Manual | |
| 5 | 1 | Printed Calibration Procedure | |
| 6 | 1 | CD | Utilities and manuals |

Signal generator procurement details

Manufacturer

Equipment manufacturer: Agilent Technologies

Signal generator description

Equipment description: 9kHz – 3GHz, EXG Vector Signal Generator.

Product code

Manufacturer’s product code: N5172B

Options

The equipment is to include the following optional features:

| <u>Order Item</u> | <u>Description</u> | <u>GSS code:</u> |
|-------------------|--|------------------|
| N5172B-503 | Frequency range 9 kHz to 3 GHz | GSTE-0009 |
| N5172B-UNW | Narrow Pulse modulation | GSTE-0011 |
| N5172B-UNT | AM, FM and phase modulation | GSTE-0013 |
| N5172B-1EM | Move RF output to the rear panel | GSTE-0014 |
| N5172B-653 | Internal baseband generator (75 Msa/s, 32 Msa) | GSTE-0015 |
| N5172B-403 | Calibrated AWGN | GSTE-0016 |
| N5172B-1CP | Rackmount and front handle kit | GSTE-0017 |

⁹ If a customer furnished signal generator is used its serial number must be supplied to Spirent to allow a licence key to be generated. All other deliverables remain unchanged.

Software licence key (required)

It should be noted that a licence key enables each specific signal generator. In order that customers can purchase the licence key(s) and cable set(s) the serial number of any customer furnished signal generators need to be supplied to Spirent. Each signal generator will also need a unique Ethernet address.