



Worcester Controls F819/829 Full Bore Firesafe Flanged Ball Valves



Experience In Motion

With the Series 819/829 designed to BS 5351, Flowserve Worcester Controls brings to the market a full bore valve which combines low cost of ownership and long service life with high operational safety and a range of features which sets the standards for others to follow.

What remains unchanged however is Worcester Controls' total dedication to quality and service support. All of this is the result of following one simple strategy – to listen and respond to the needs of our customers.

Anti-blowout stem - Inserted from inside of valve body for greater safety

Actuator mounting - Conforms to ISO 5211 for ease of actuation

Anti-static stem - Ensures electrical continuity between ball and body

Seats - Wide range of seat materials to suit customer applications

Ball - 316 stainless steel as standard with pressure equalising hole to balance cavity pressure with line pressure when valve is open. Parallel ported ball maximises flow and minimises pressure drop

Body seals - PTFE coated graphite as standard for firesafe integrity, eliminates media contamination.

Seat design - Cavity pressure relieving (CPR) seats ensure that pressure generated through media expansion when the valve is closed is safely relieved upstream

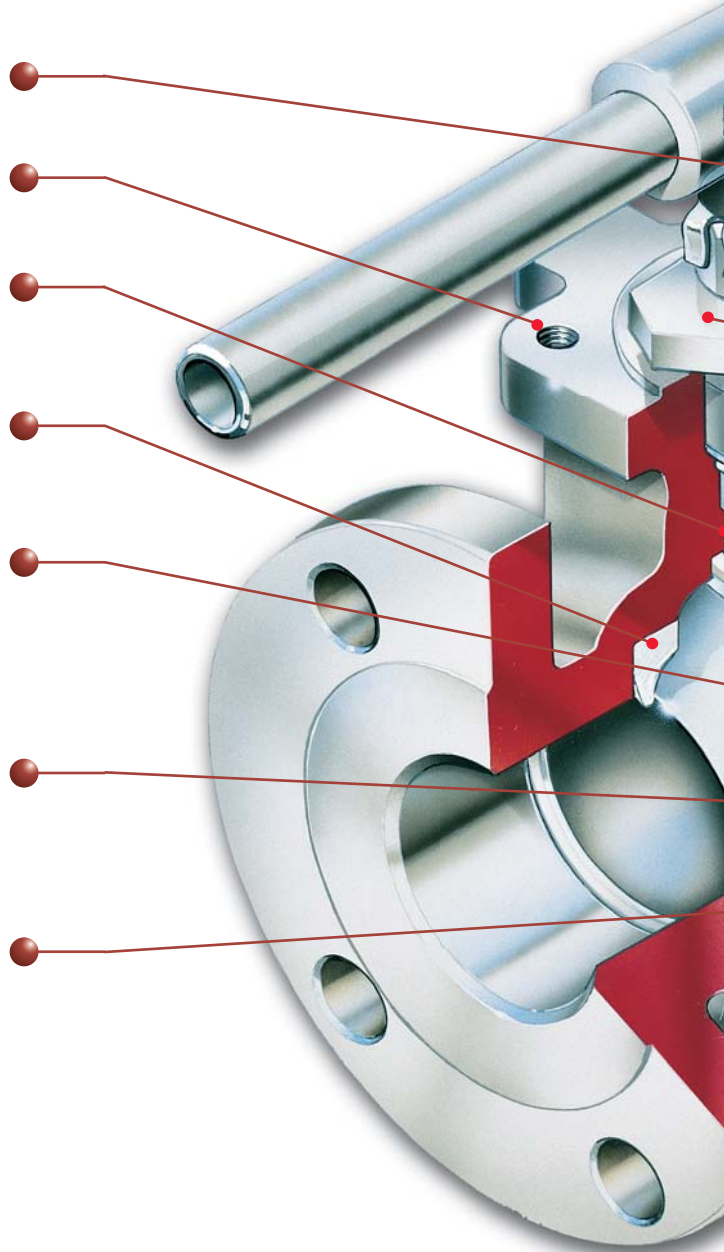

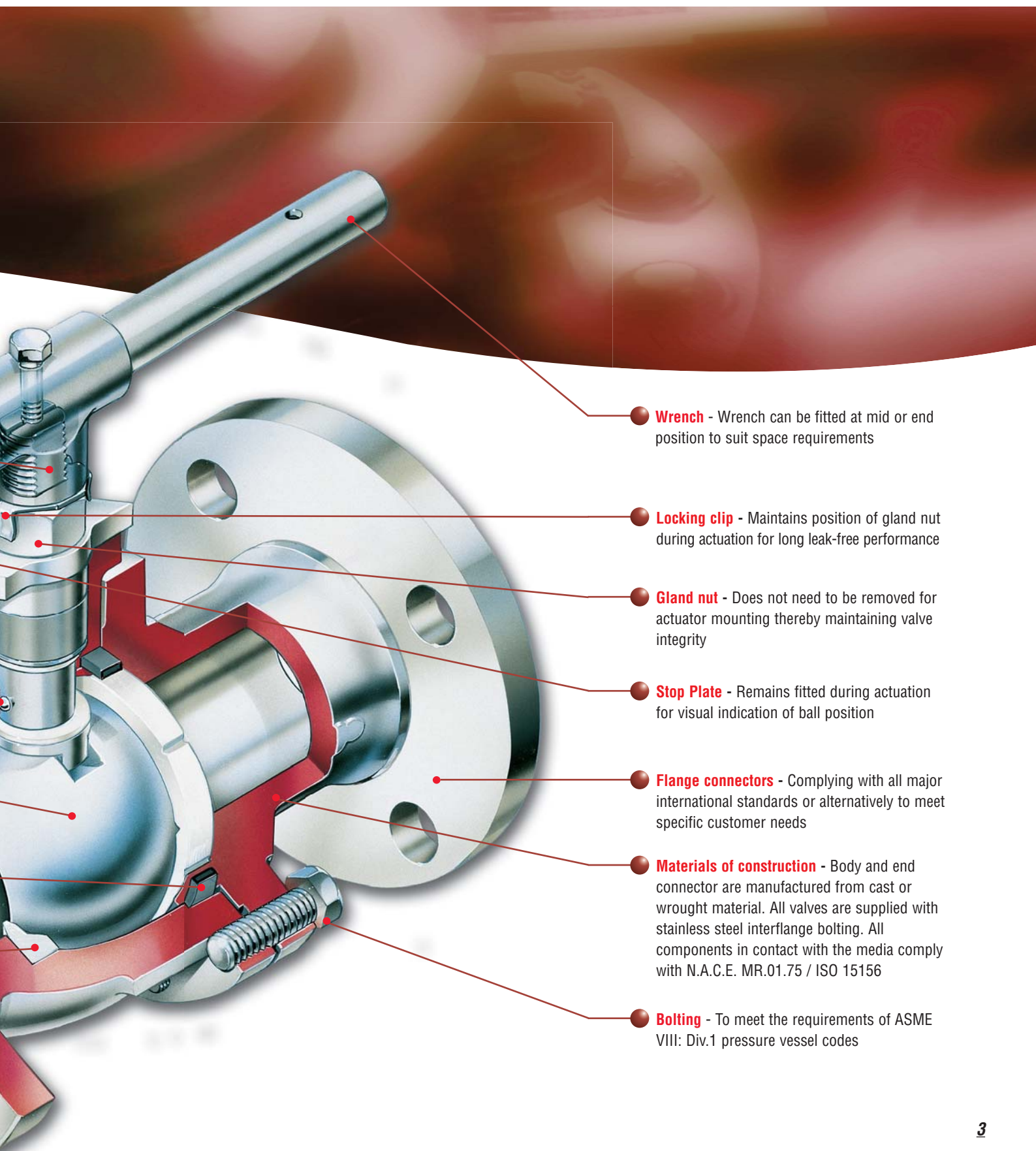

- **Wrench** - Wrench can be fitted at mid or end position to suit space requirements
- **Locking clip** - Maintains position of gland nut during actuation for long leak-free performance
- **Gland nut** - Does not need to be removed for actuator mounting thereby maintaining valve integrity
- **Stop Plate** - Remains fitted during actuation for visual indication of ball position
- **Flange connectors** - Complying with all major international standards or alternatively to meet specific customer needs
- **Materials of construction** - Body and end connector are manufactured from cast or wrought material. All valves are supplied with stainless steel interflange bolting. All components in contact with the media comply with N.A.C.E. MR.01.75 / ISO 15156
- **Bolting** - To meet the requirements of ASME VIII: Div.1 pressure vessel codes

Pressure/Temperature Ratings

PTFE SEATS (T)

Virgin PTFE is the most common sealing material and is suitable for almost all media as it has excellent chemical resistance.

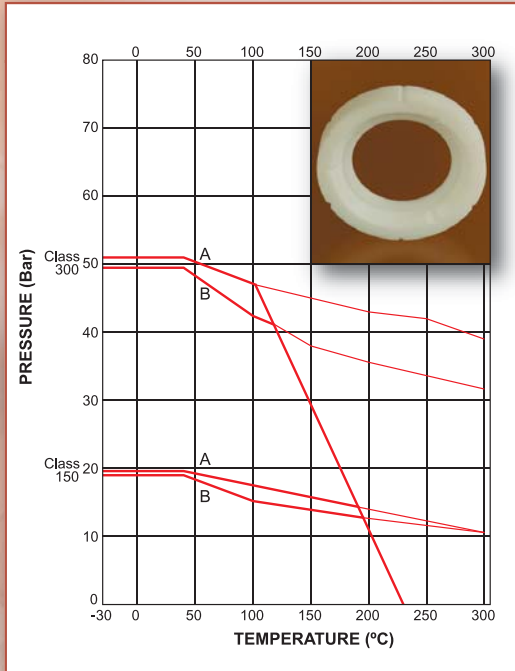

15% GLASS FILLED PTFE (R)

Glass re-inforced PTFE seats are stronger than virgin and have higher pressure/temperature ratings. Chemical resistance as per virgin PTFE.

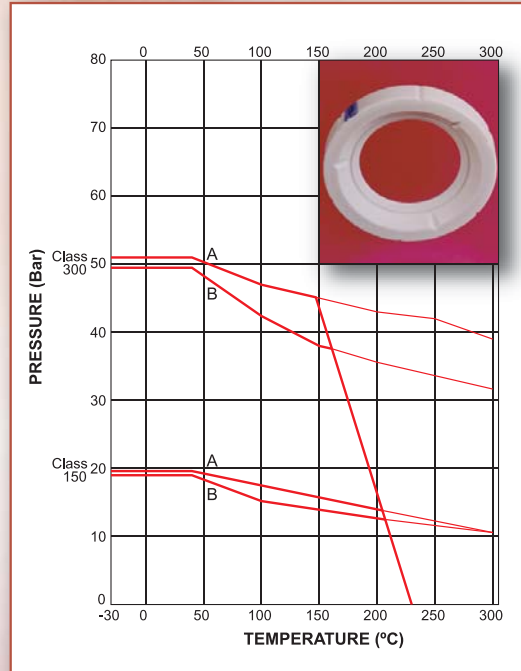

25% GLASS FILLED PTFE (H)

Glass re-inforced PTFE material offering a greater pressure / temperature capability than the R seat.

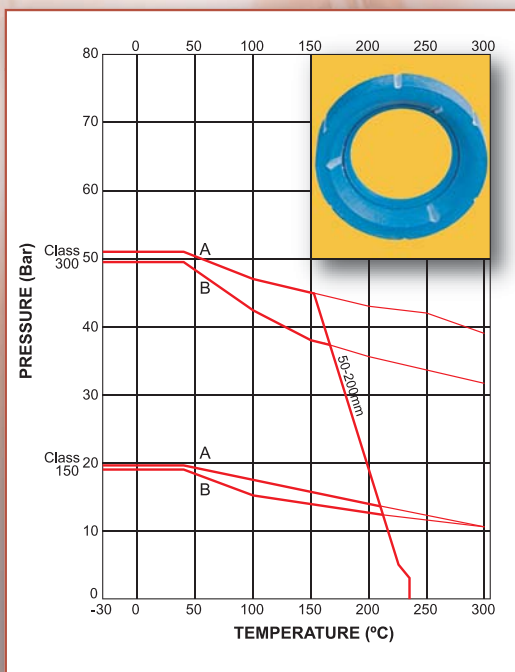

FLUOROFILL (P)

Carbon, glass and graphite filled PTFE material, an excellent seat material for steam and thermal services. Due to its high cycling capabilities, it is the recommended soft seat for modulating control applications.

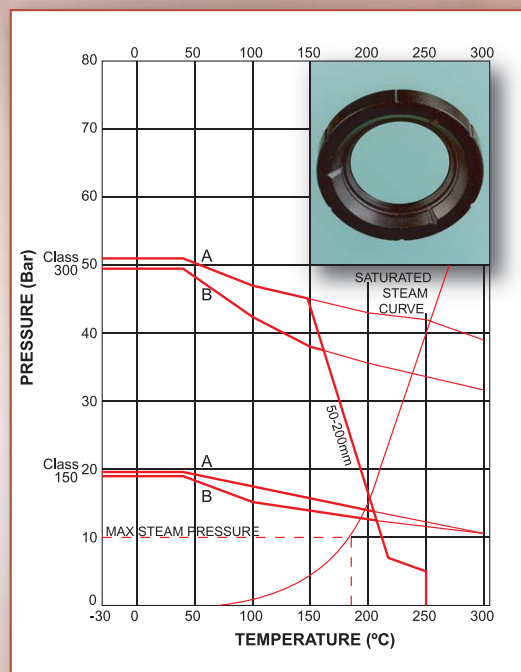

Pressure/Temperature Ratings

UHMWPE (U)

Ultra High Molecular Weight Polyethylene offers good performance characteristics in applications where PTFE is not suitable (for example on tobacco duty). It also has good abrasion resistance.

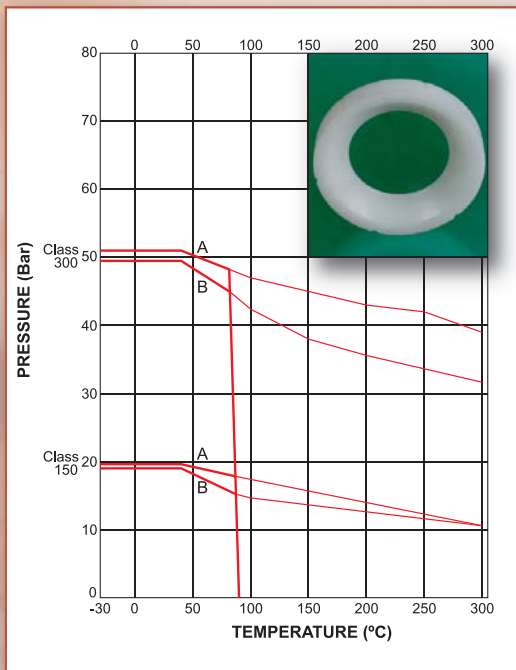

PEEK

PEEK is Poly Ether Ether Ketone, a material which demonstrates outstanding pressure capabilities at elevated temperatures. PEEK has excellent chemical and abrasion resistance.

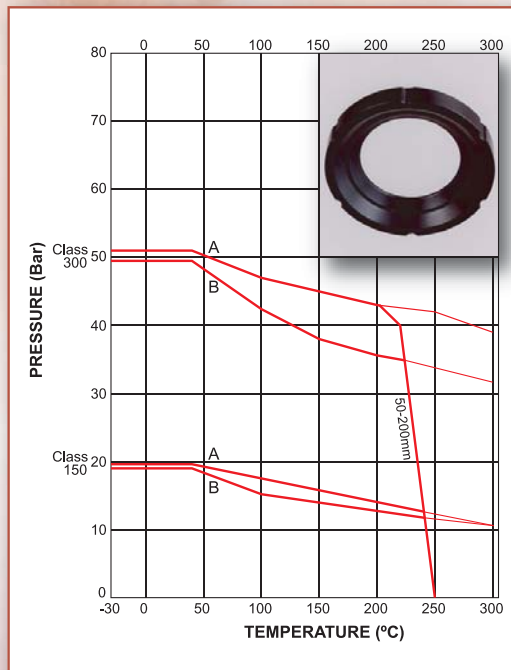

METAL – ALPHA (N)

A 316L sintered metal seat impregnated with PTFE, this material combines the strength and abrasion resistance of metal with the lubrication properties of PTFE. A graphite-impregnated metal seat is also available.

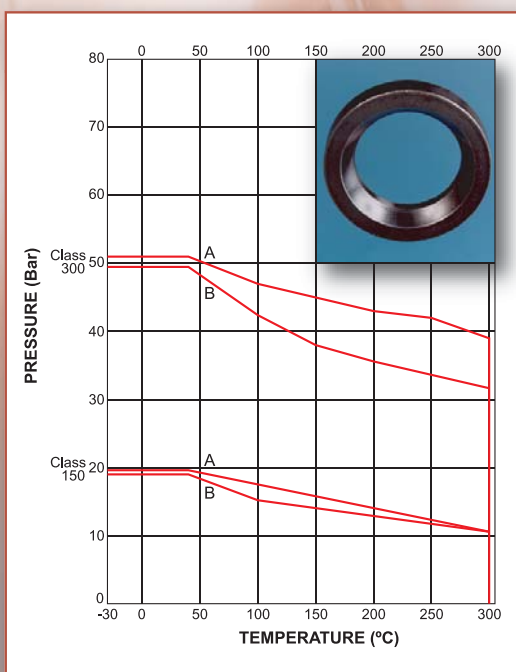

Key **A** = Carbon Steel Body Rating
 B = Stainless Steel Body Rating
 (In accordance with BS1560 / EN 1759)

IMPORTANT NOTE

The information given in the pressure/temperature graphs on pages 4/5 indicates the maximum performance capabilities of these seat materials. The full potential of virgin and re-inforced PTFE can be realised in the standard Worcester valve build. For more demanding applications requiring the greater pressure/temperature capabilities of the other seat materials, it is essential that the appropriate valve build is specified.

Examples of these applications include the following:

- Thermal Fluids
- Nuclear Service
- Oxygen Service
- Tobacco
- Ammonia
- Helium
- Toxic Chemicals (eg. Chlorine, Hydrogen Peroxide, Phosgene etc.) – Enviro-safe Build
- Vacuum Service and many more.

To ensure that the correct valve is supplied, please consult Worcester Controls.

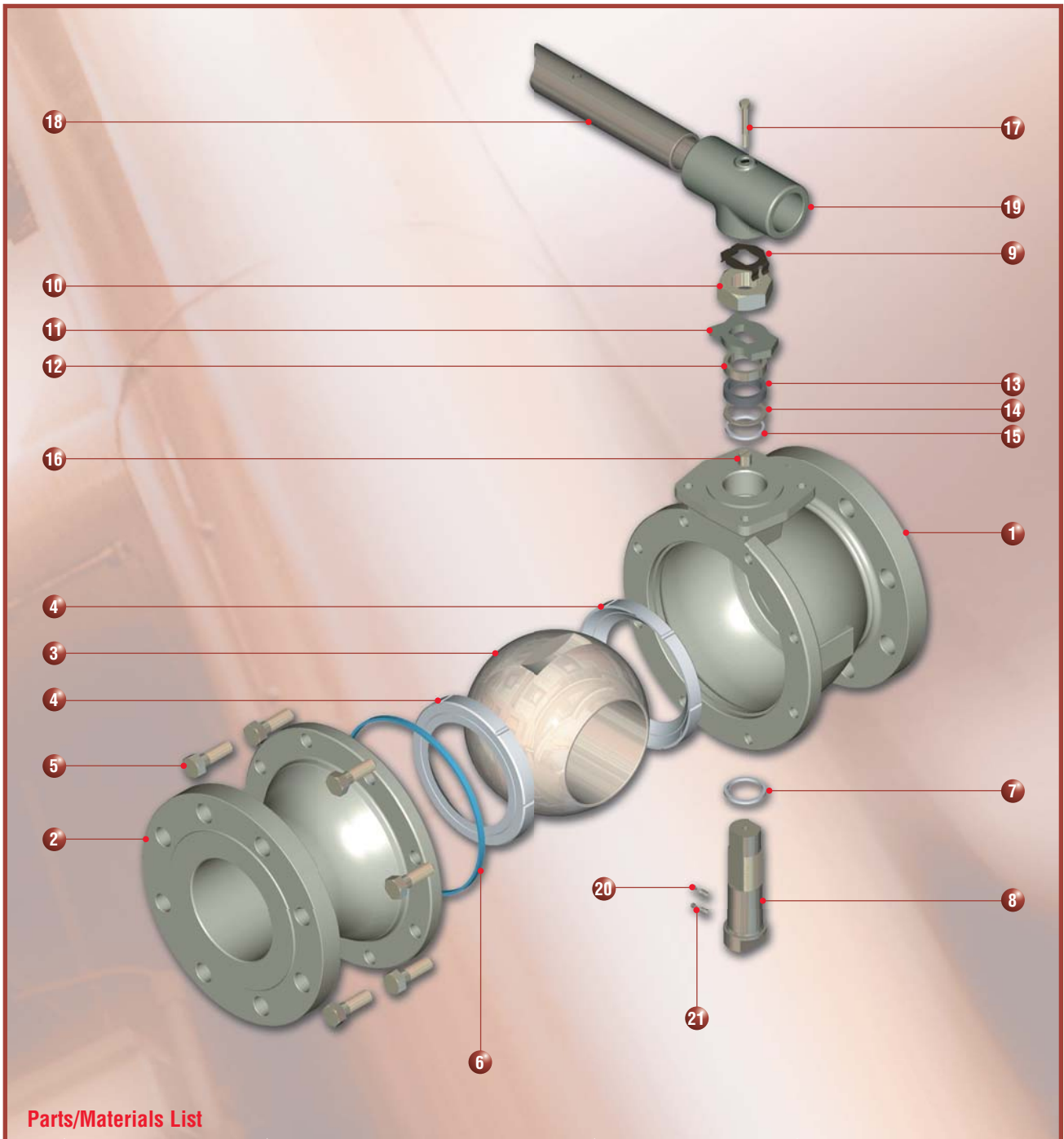

Parts/Materials List

ITEM	DESCRIPTION	MATERIAL	ITEM	DESCRIPTION	MATERIAL
1. & 2.	Body & Body Connector	Stainless Steel ASTM-A351 CF8M/ Carbon Steel ASTM A216 WCB	11.	Stop Indicator	Stainless Steel 316 / Zinc Plated Carbon Steel
3.	Ball	Stainless Steel 316 A351 CF8M	12.	Gland	Stainless Steel 316
4.	Seat	PTFE Virgin, PTFE 15% glass filled, VXI, Fluorofill, PEEK, metal or other options (see pages 4 & 5)	13.	Gland Packing	Flexible Graphite
5.	Body Connector Screw	Stainless Steel ASTM A193M B8 CL2/B8M CL2	14.	Stem Location Ring	Stainless Steel 316
6.	Body Seal	PTFE Coated Flexible Graphite	15.	Secondary Stem Seal	Virgin PTFE
7.	Stem Thrust Seal	Re-inforced PTFE	16.	Stop Pin	Stainless Steel
8.	Stem	Stainless Steel A479 316	17.	Wrench Fixing Bolt	Stainless Steel / Carbon Steel
9.	Gland Nut Locking Clip	Stainless Steel	18.	Wrench	Zinc Plated Carbon Steel
10.	Gland Nut	Zinc Plated Stainless Steel / Carbon Steel	19.	Wrench Head	Zinc Plated Carbon Steel
			20.	Anti-static Spring	Stainless Steel
			21.	Anti-static Plunger	Stainless Steel

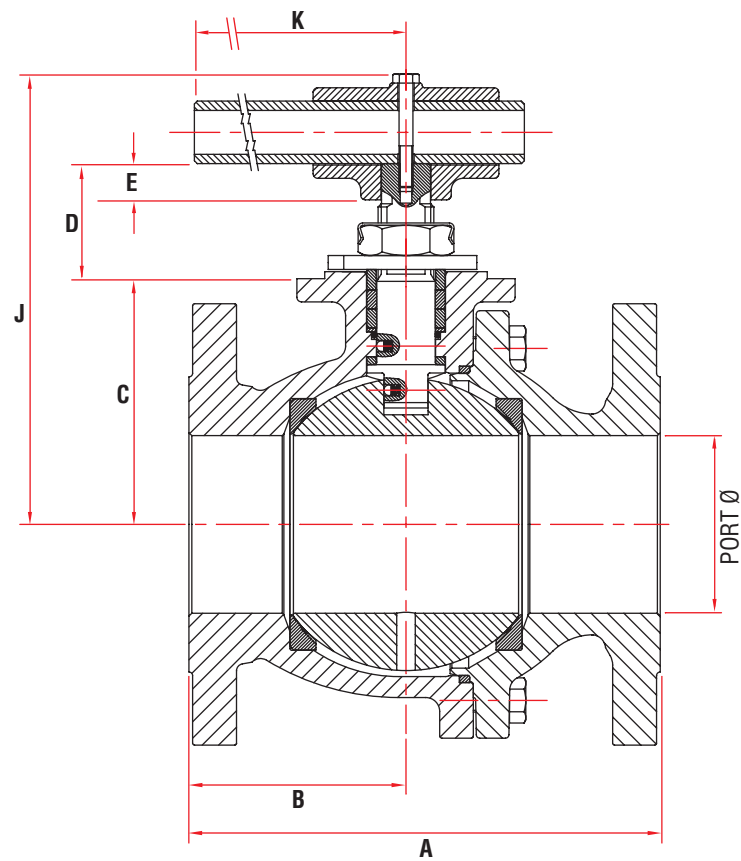
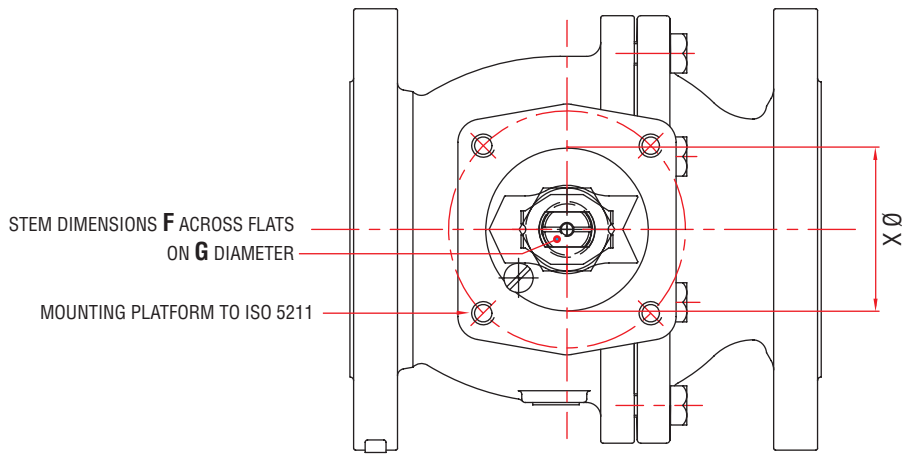

Valve Dimensions (mm)

819 (ANSI Cl. 150)

829 (ANSI Cl. 300)

Valve Size (Port Ø)	A	B	C	D	E	F A/F MAX	G Dia. MAX	J	K	X Dia.	ISO MTG	A	B	C	D	E	F A/F MAX	G Dia. MAX	J	K	X Dia.	ISO MTG
DN50 (51.1)	178	74	87.6 86.9	43.8 41.5	-	14.0	M20x 1.5p	156	225	55.0	F07	216	74	87.6 86.9	43.8 41.5	-	14.0	M20x 1.5p	156	225	55.0	F07
DN80 (76.5)	203	94	112.4 111.6	51.1 48.4	17.2	15.1	21.1	201	350	55.0	F07	283	94	119.9 119.1	55.7 53.0	21.4	19.3	27.2	214	557	70.0	F10
DN100 (102.3)	229	117	140.6 139.8	55.9 53.2	21.4	19.3	27.1	235	557	70.0	F10	305	132	147.1 146.3	73.0 70.3	28.6	26.6	33.2	275	850	85.0	F12
DN150 (151.0)	394	179	182.4 181.6	73.0 70.3	28.6	26.6	33.1	310	850	85.0	F12	403	179	194.6 193.8	77.4 74.7	29.6	30.4	37.9	327	850	100.0	F14
DN200 (203.3)	457	206	237.4 236.6	77.4 74.7	29.6	30.4	37.8	-	-	100.0	F14	502	231	256.2 255.3	88.4 85.5	36.0	34.5	42.6	-	-	130.0	F16

Product Coding (Typical)

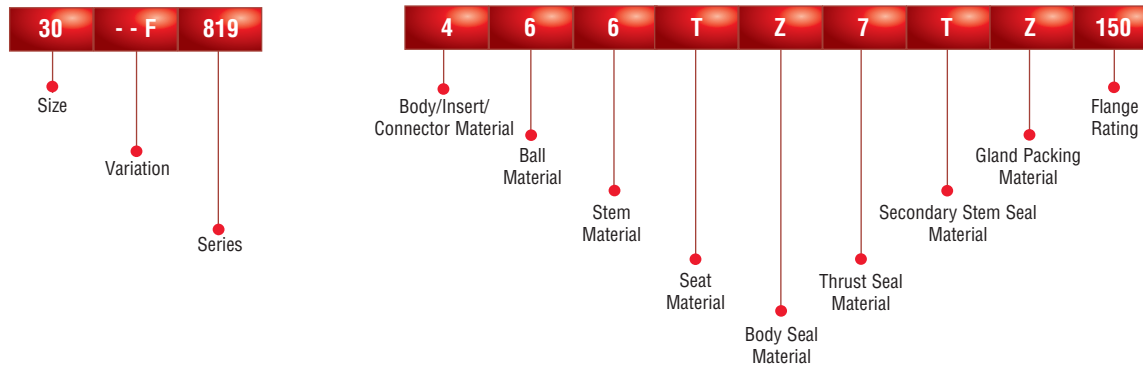

Notes

1. When wrench not fitted, flats on stem when parallel to pipeline axis denote open position.
2. Installation, Operating and Maintenance instructions are supplied with product and also available on request.
3. Limiting stem input torque figures are based on random practical laboratory tests. For critical applications where a guaranteed figure is essential, consult technical sales.
4. Compliance with ASME B16.10 requires that 50, 80 and 100mm 819 valves are of shorter pattern face to face lengths than the earlier standard F96 series.

Standards of Compliance

Valve Specification	BS 5351, Valves for petroleum industry Lloyds Register type approved. Pressure Equipment Directive 97/23/EC
Flanges 819	BS EN 1759-1 Class 150
Flanges 829	BS EN 1759-1 Class 300
Face to Face Lengths	ASME B16. 10 as standard. 50, 80 & 100mm Class 150 to EN 558-2 Table 6 Series 12 optional (See Note 4)
Pressure Test Specification	BS EN 12266 Part 1
Firesafe Specification	ISO 10497, API 607
Quality Assurance	ISO 9001, ISO 17025 (optional)
Sour Gas Applications	NACE MR.01.75 / ISO 15156 (internal only)

Technical Information

Valve Size (mm)	Series	Weight Kg	Limiting Stem input Torque - Nm (see note 3)	Valve Operating Torque*	Flow Coefficients	
					Cv	Kv
DN 50	819	12.0	192	35	501	423
	829	15.0		50		
DN 80	819	22.0	336	165	1158	978
	829	32.0	620	300		
DN 100	819	40.0	620	330	2118	1789
	829	57.0	1138	675		
DN 150	819	88.0	1138	500	5074	4287
	829	117.0	2006	1020		
DN 200	819	176.0	2006	1430	9337	7889
	829	236.0	2910	2030		

*Valve operating torques at full differential pressure with 'T' Seats

Cv - Flow in US GPM Pressure - psi
Kv - Flow in M³/hr Pressure - bar

WCEBR0015-01 Printed in Germany. (Replaces PB43 iss 06/03)

To find your local Flowserve representative:

For more information about Flowserve Corporation, visit www.flowserve.com or call USA 1 800 225 6989



Flowserve Flow Control

A Division of Flowserve GB Ltd.
Burrell Road, Haywards Heath
West Sussex RH16 1TL
United Kingdom
Telephone: +44 (0)1444 314400
Telefax: +44 (0)1444 314401
Email: wvukinfo@flowserve.com

Due to continuous development of our product range, we reserve the right to alter the dimensions and information contained in this leaflet as required. Information given in this leaflet is made in good faith and based upon specific testing but does not, however, constitute a guarantee.