

BOSS Sealed Expansion Vessel Overview

Description:

The BOSS Sealed Expansion Vessel is intended for use on sealed heating and chilled systems. The vessel is comprised of a high strength steel shell and butyl rubber diaphragm. Sealed systems maintain the operating pressure in heating and cooling systems, by using an expansion vessel to accommodate any expansion or contraction caused by system temperature changes.

Certifications and Standards Applied:

- PED 97/23/EC
- CE Approved
- BS 4814:1990

Maximum Operating Conditions:

- Min. working temperature: -10 °C
- Max. vessel temperature (diaphragm): 70 °C.
- Max. supply temperature (boiler): 90 °C.
- Max. working temperature (design): 120 °C.

Common Product Features:

- Easy to install with long service life
- Suitable to be used in large and small systems
- Fixed diaphragm
- Nitrogen air valve counter sunk in with protective cap

Application of Use:

- Heated water systems
- Chilled waters



Dimensions:

Type	Pre Charge (Bar)	Maximum Working Pressure (Bar)	Volume (l)	Dimensions (mm)			Connections (BSP M) (G)	Weight (Kg)	Order Code
				Diameter ϕ A	Height B	ϕ C			
BOSS 2 Litre	0.5	6	2	216	144	-	3/4"	1.7	19711008
BOSS 4 Litre	0.5	6	4	216	192	-	3/4"	2.1	19711019
BOSS 8 Litre	1.5	6	8	245	277	-	3/4"	3.2	19711030
BOSS 12 Litre	1.5	6	12	286	309	-	3/4"	4.5	19711041
BOSS 18 Litre	1.5	6	18	328	323	-	3/4"	5.7	19711052
BOSS 25 Litre	1.5	6	25	358	356	-	3/4"	7.3	19711063
BOSS 35 Litre	1.5	6	35	396	435	263	3/4"	8.1	19711074
BOSS 50 Litre	1.5	6	50	437	493	263	3/4"	11.4	19711085
BOSS 80 Litre	2.0	6	80	519	534	360	1"	15.0	19711096
BOSS 100 Litre	2.0	6	110	484	784	360	1"	18.8	19711104
BOSS 150 Litre	2.0	6	140	484	1024	360	1"	25.3	19711115
BOSS 200 Litre	2.5	6	140	484	1300	450	1"	27.6	19711126
BOSS 250 Litre	2.5	6	200	600	1153	450	1"	35.9	19711192
BOSS 300 Litre	2.5	6	300	600	1330	450	1"	44.1	19711137
BOSS 350 Litre	2.5	6	350	790	1027	450	1"	52.9	19711403
BOSS 400 Litre	2.5	6	425	790	1180	610	1"	59.1	19711148
BOSS 500 Litre	2.5	6	500	790	1330	610	1"	66.7	19711211
BOSS 600 Litre	2.5	6	600	790	1540	610	1"	70.1	19711159
BOSS 800 Litre	2.5	6	800	790	1888	610	1"	88.0	19711170
BOSS 1000 Litre	2.5	6	1000	790	2268	610	1"	101.4	19711181

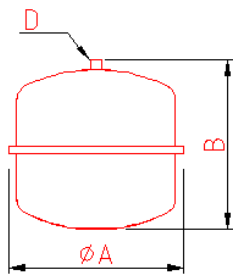

2 - 25 Litres

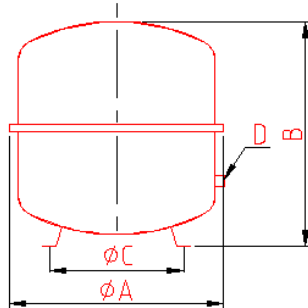

35 - 80 Litres

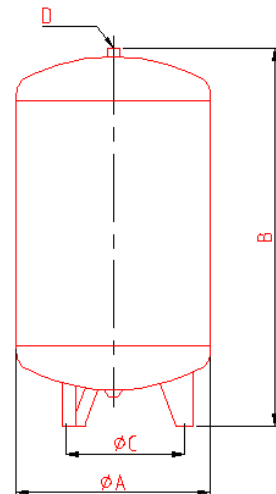

110 - 1000 Litres

Installation & Placement:

To ensure that the temperature at the BOSS diaphragm does not exceed 70°C (system flow <90°C), the vessel should be installed on the coldest part of the system, (typically the return pipe to the heat exchanger). For systems running at elevated temperatures (90°C flow), an intermediate vessel may be required to provide additional heat dissipation.

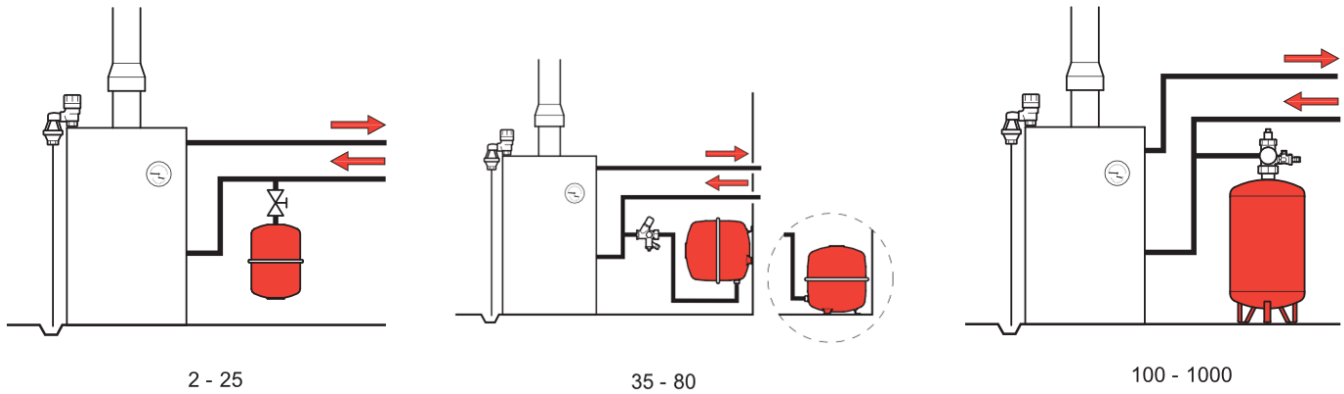

Mounting of the BOSS vessels

- 2 – 25 Litres Vessels are to be mounted by means of a suspension bracket (MB 2)
- 35 – 80 Litres Vessels are to be mounted with the feet on the wall or upright on the bottom