

**BOSS™**

**SUMP PUMPS**



## INTRODUCTION



Pipeline & Heating Solutions

**BSS is a leading distributor of pipeline and heating solutions to the industrial, heating and ventilation market sectors and is committed to providing customers with the highest levels of service, technical advice and a single source solution.**

We offer a comprehensive range of products from our national branch network. Each BSS branch has a wide range of products and has their own internal and external sales team as well as a fully merchandised trade counter.

Established during the 1960s, AMS Pumps has built up an excellent reputation for delivering value for money and outstanding service to customers through sourcing technical solutions, products and packages.

Since they were acquired by BSS in 1987 to provide a specialist pumps division, AMS have developed using the BSS branch network to be the largest national distributor of pumps and pumping equipment in the UK and were the Pump Industry Awards Distributor of the Year in 2007 and 2008.



**Technical Support: 0870 609 2101**

BSS can supply pumps for a multitude of applications across the food processing, construction, industrial and water markets.

Products supplied include:

- Boiler feeds
- Heating and chilled water circulation
- Pressurisation and sealed systems
- Booster sets
- Chemical dosing
- Boreholes
- Slurry removal
- High pressure wash downs
- Solids handling pumps
- Oil transfers
- Waste water and sewage
- Hygienic pumps

## AMS Aftersales

A comprehensive range of after sales services for all applications:

- Spares
- Repairs
- Commissioning
- Servicing and service contracts

AMS Aftersales: **0870 850 3886**

Email: [amsse@bssgroup.com](mailto:amsse@bssgroup.com)

<b>BOSS 21/21 VOX</b>	<b>4-5</b>
<b>BOSS 36</b>	<b>6-7</b>
<b>BOSS 31/51</b>	<b>8-9</b>
<b>BOSS 101</b>	<b>10-11</b>
<b>BOSS 91</b>	<b>12-13</b>
<b>BOSS 84/104</b>	<b>14-15</b>
<b>SPARES &amp; ACCESSORIES</b>	<b>16-18</b>
<b>E BOX CONTROL PANEL</b>	<b>19</b>
<b>RANGE SUMMARY</b>	<b>20</b>
<b>PUMPS CURVES</b>	<b>21</b>
<b>AMS PUMPS</b>	<b>22</b>
<b>BSS LITERATURE</b>	<b>23</b>
<b>BSS BRANCHES</b>	<b>24</b>



The information contained in this publication is believed to be correct and complete at the time of printing but it is an approximate guide only. Due to limitations in the printing process, images may not be representative of their true colours and colour variations may occur due to the natural origin of the products. Stock may vary from branch to branch and is subject to availability. Any industry accreditations portrayed (eg WRAS, BBA etc) are correct at time of going to press but may be subject to change without prior notice. All photographs are a guide only and do not necessarily represent the products available. BSS Industrial reserves the right to change product details and designs without prior notice. To the fullest extent permitted by law, BSS Industrial assumes no liability or responsibility for typographical and clerical errors and omissions in this publication (which may be corrected by us without liability) and this publication does not form the basis of any contract. All products sold are subject to our Group Sale Terms, a copy of which are available on request or are otherwise available at [www.bssindustrial.co.uk](http://www.bssindustrial.co.uk) Travis Perkins Group is the owner of the registered trademark BOSS.

**Email: [amspumps@bssgroup.com](mailto:amspumps@bssgroup.com)**

# BOSS 21/21 VOX

## SUBMERSIBLE PUMP FOR DRAINAGE APPLICATIONS

All BOSS Products are supplied with the confidence of high quality and reliability as standard.

Full service and technical back up.

	Code
BOSS 21	80630010
BOSS 21 VOX	80630021

	BOSS 21	BOSS 21 VOX
Head up to	5m	6.5m
Flow up to	1.9l/s	3l/s
Float Auto	YES	YES
Supply volts	230V	230V



**DURABILITY** - Anti-corrosive rust proof materials

**OPERATION** - Automatic float switch control

**CAPABILITY** - Minimum suction 2-3mm

**INSTALLATION** - Fitted with 10m of mains cable

### APPLICATIONS

Multi purpose submersible electric drainage pumps manufactured in rust free anti-corrosion material. Designed for pumping clean and waste water containing solids in suspension up to a maximum of 5mm in diameter (20mm max for the BOSS 21 VOX). Ideal for cellar drainage and pumping out flooded areas.

### CONSTRUCTION FEATURES OF THE PUMP

Pump body and impeller made in technopolymer, motor casing and shaft made in stainless steel. Motor shaft lip seal arrangement.

### CONSTRUCTION FEATURES OF THE MOTOR

Dry asynchronous sealed motor type cooled by the pumped liquid. Rotor mounted on greased for life bearings, oversized and selected to guarantee greater noise reduction and durability. Thermal overload motor protection as standard with auto reset 230v / 110v 50hz 1PH only. Constructed in IEC 2-3 IEC61-69 (EN60335-2-41) standards.

### EXTRAS

BOSS 21 supplied with a 25mm hose connection elbow.  
BOSS 21 VOX supplied with a 30mm connection elbow.

# CLEAR WATER PLASTIC PUMPS

## TECHNICAL SPECIFICATION

	BOSS 21	BOSS 21 VOX
Head up to	5m	6.5m
Flow up to	1.9l/s	3l/s
Closed valve	5.5m	7m
Min Sump Dimensions (mm)	H300 x W400 x D400	H335 x W400 x D400
Outlet size	1¼"F BSP	1¼"F BSP
Max immersion depth	10m	10m
Min water level	65mm	65mm
Solids handling	5mm	20mm
Max liquid temp	35°C	35°C
Motor Size	0.22kW	0.44kW
Mains supply	230V	230V
Running current	0.9A	3.2A
Float switch	YES	YES
Supply cable	10m	10m

### Motor Protection Class

IP68

### Insulation Class

F

### Minimum Suction

2-3 mm

### Standard Voltage

220-240V 1PH 50Hz

### Motor Rating

Continuous running with liquid at 35°C max and pump completely submerged

## MATERIALS

Parts in contact with the pumped liquid	Materials
Pump Body	Technopolymer
Impeller	Technopolymer
Motor Shaft	Stainless Steel AISI 304
O-ring Gasket	NBR
Motor Casing	Stainless Steel AISI 304
Float Control Cable	Technopolymer HO7 RN-F (PCP type EM2)

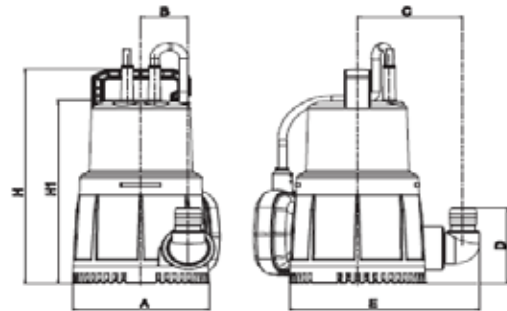

## DIMENSIONS

MODEL	A	B	D	H	H1	E	DIA / DNM	Packaging DIM			Weight Kg
								L/A	L/B	H	
BOSS 21	150	50	90	220	210	200	1¼"F BSP	160	195	260	3.5
BOSS 21 VOX	150	50	110	255	240	200	1¼"F BSP	160	195	260	4.4

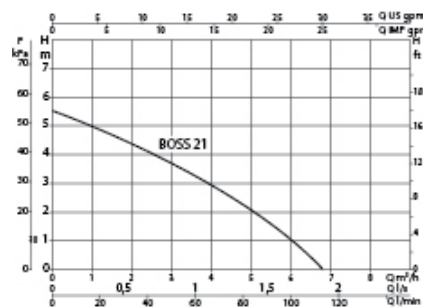
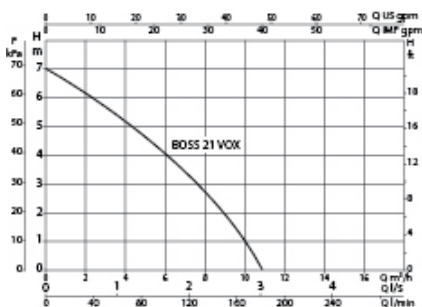

# BOSS 36

## SUBMERSIBLE PUMP FOR DRAINAGE APPLICATIONS

All BOSS Products are supplied with the confidence of high quality and reliability as standard.

**Full service and technical back up.**

	Code
BOSS 36 110V	80630054
BOSS 36 230V	80630065

	BOSS 36
Head up to	8.8m
Flow up to	3.1l/s
Float Auto	YES
Supply volts	110V / 230V

**DURABILITY** - Anti-corrosive rust proof materials

**OPERATION** - Automatic integral float control

**CAPABILITY** - Low suction Depth 2 -3 mm on manual

**INSTALLATION** - Fitted with 10m of mains cable

### APPLICATIONS

Multi purpose submersible electric drainage pumps manufactured in rust free anti-corrosion material. Uniquely designed for installation in restricted areas down to 200mm x 200mm. Designed for pumping clear water containing solids in suspension up to a maximum of 5mm in diameter. Features a fully integrated float switch for automatic operation with switchable control from manual to automatic. Also features a removable cover for cleaning of the float switch mechanism and ultra low suction capacity of 2-3mm when in manual mode. Ideal for cellar drainage and pumping out flooded areas.



### CONSTRUCTION FEATURES OF THE PUMP

Pump body and impeller made in technopolymer, motor casing and shaft made in stainless steel. Motor shaft double lip seal arrangement.

### CONSTRUCTION FEATURES OF THE MOTOR

Dry asynchronous sealed motor type cooled by the pumped liquid. Rotor mounted on greased for life bearings, oversized and selected to guarantee greater noise reduction and durability. Thermal overload motor protection as standard with auto reset 230v / 110v 50hz 1PH only. Constructed in IEC 2-3 IEC61-69 (EN60335-2-41) standards.

## TECHNICAL SPECIFICATION

	BOSS 36
Head up to	8.8m
Flow up to	3.1/s
Closed valve	9m
Min Sump Dimensions (mm)	H350 x W200 x L200
Outlet size	1¼" M BSP
Max immersion depth	10m
Min water level	2-3mm (manual)
Solids handling	5mm
Max liquid temp	40°C
Motor Size	0.4kW
Mains supply	Select
Running current	110V - 5.9 A / 230V - 2.6 A
Float switch	YES - INTEGRAL
Supply cable	10 m

### Motor Protection Class

IP68

### Insulation Class

F

### Voltage options

110V/240V 1PH 50Hz

### Motor Rating

Continuously even with the motor partially submerged

Parts in contact with the pumped liquid	Materials
Pump Body	Technopolymer
Impeller	Technopolymer
Motor Shaft	Stainless Steel AISI 304
O-ring Gasket	NBR
O-ring Gasket	NBR
Motor Casing	Stainless Steel AISI 304
Ceramic Bush	Stainless Steel AISI 304
Upper Bearing Support	Cast Aluminium
Lower Bearing Support	Cast Aluminium
Handle	PP20TC
Cable	HO7 RN-F (PCP type EM2)

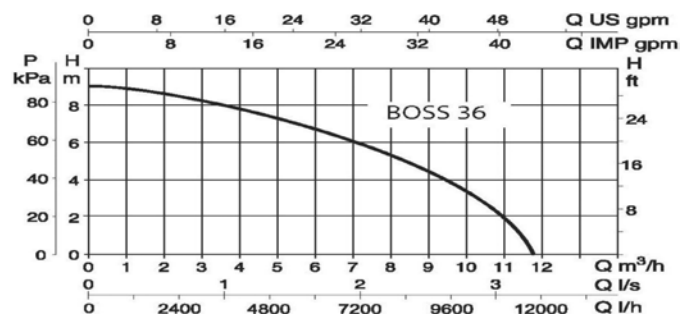
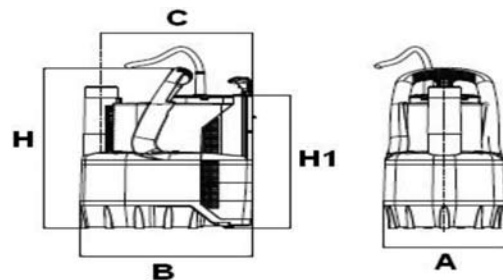

## DIMENSIONS

MODEL	A	B	C	H	H1	E	DIA / DNM	Packaging DIM			Weight Kg
								L/A	L/B	H	
BOSS 36	158	225	200	400	265	200	1¼" M BSP	190	220	330	5.1

# BOSS 31/51

## SUBMERSIBLE PUMP FOR DRAINAGE APPLICATIONS

All BOSS Products are supplied with the confidence of high quality and reliability as standard.

**Full service and technical back up.**

	Code	
BOSS 31 110V	80630032	
BOSS 31 230V	80630043	
BOSS 51	80630076	

	BOSS 31	BOSS 51
Head up to	6.3m	9.3m
Flow up to	2.5l/s	3.75l/s
Float Auto	YES	YES
Supply volts	110V / 230V	230V



**DURABILITY** - Full stainless steel construction materials

**OPERATION** - Automatic float switch control

**CAPABILITY** - Solids handling up to 10mm

**INSTALLATION** - Fitted with 10m of mains cable

## APPLICATIONS

Multi purpose submersible electric drainage pumps manufactured stainless steel material. Designed for pumping clean and waste water containing solids in suspension up to a maximum of 10mm in diameter. Ideal for cellar drainage and pumping out flooded areas.

## CONSTRUCTION FEATURES OF THE PUMP

Pump body and impeller made completely in stainless steel, motor casing and shaft made in stainless steel. Motor shaft mechanical seal arrangement.

## CONSTRUCTION FEATURES OF THE MOTOR

Dry asynchronous sealed motor type cooled by the pumped liquid. Rotor mounted on greased for life bearings, oversized and selected to guarantee greater noise reduction and durability. Thermal overload motor protection as standard with auto reset 230v / 110v 50hz 1PH only. Constructed in IEC 2-3 IEC61-69 (EN60335-2-41) standards.



## TECHNICAL SPECIFICATION

	BOSS 31	BOSS 51
Head up to	6.3m	9.3m
Flow up to	2.5l/s	3.75l/s
Closed valve	7m	10m
Min Sump Dimensions (mm)	H374 x W400 x D400	H374 x W400 x D400
Outlet size	1¼"F BSP	1¼"F BSP
Max immersion depth	10m	10m
Min water level	65mm	65mm
Solids handling	10mm	10mm
Max liquid temp*	50°C	50°C
Motor Size	0.25kW	0.45kW
Mains supply	110V/230V	230V
Running current	5.0A/1.8A	3.0A
Float switch	YES	YES
Supply cable	10m	10m

### Motor Protection Class

IP68

### Insulation Class

F

### Standard Voltage

110V/230V 1PH 50HZ

### Motor Rating\*

Continuous running with liquid at 35°C max and pump completely submerged

## MATERIALS

Parts in contact with the pumped liquid	Materials
Pump Body	Stainless Steel AISI 304
Support	Stainless Steel AISI 304
Impeller	Stainless Steel AISI 304
Motor Shaft	Stainless Steel AISI 416
Mechanical Seal	Silicon Carbide/Allumina
O Ring	NBR
Filter Grid	Stainless Steel AISI 304
Motor Casing	Stainless Steel AISI 305
Pump Liner	Stainless Steel AISI 306
Protection Cover	Technopolymer
Main Cable & Float Cable	HO7 RN-F (PCP Type EM2)

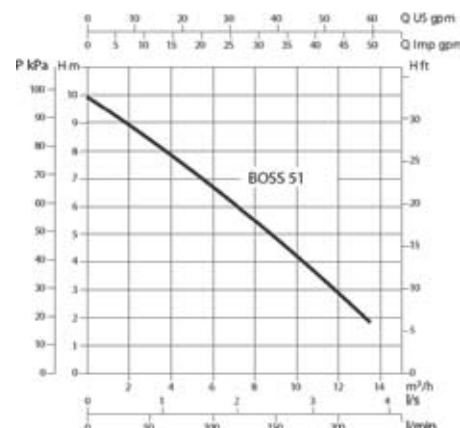
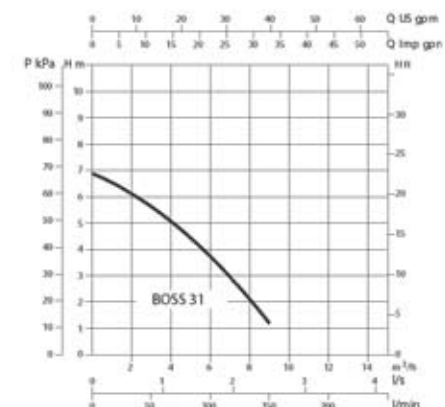
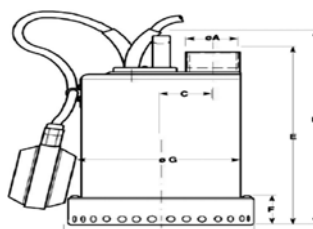

## DIMENSIONS

MODEL	B	C	D	E	F	G	DIA / DNM	Weight Kg
BOSS 31	150	50	90	220	210	200	1¼"F BSP	5.5
BOSS 51	154	43	234	214	35	132	1¼"F BSP	6.2

# BOSS 101

## SUBMERSIBLE PUMP FOR DRAINAGE APPLICATIONS

All BOSS Products are supplied with the confidence of high quality and reliability as standard.

**Full service and technical back up.**

	Code
BOSS 101 - 110V	80630120
BOSS 101 - 230V	80630098
BOSS 101 - 400V	80630109

	BOSS 101
Head up to	14.5m
Flow up to	6.6l/s
Float Auto	YES
Supply volts	see above

**DURABILITY** - Strong die-cast aluminium construction

**OPERATION** - Automatic float switch control

**CAPABILITY** - Solids handling up to 5mm

**INSTALLATION** - Fitted with 10m of mains cable

### APPLICATIONS

Multi purpose submersible electric drainage pumps manufactured in anodised die-cast aluminium. Designed for pumping clean and waste water containing solids in suspension up to a maximum of 5mm in diameter. Ideal for cellar drainage and pumping out flooded areas.

### CONSTRUCTION FEATURES OF THE PUMP

Pump body and impeller in anodised die-cast aluminium, impeller made in special reinforced nylon with corrosion-proof fibreglass. Motor shaft mechanical seal arrangement.



### CONSTRUCTION FEATURES OF THE MOTOR

Dry asynchronous sealed motor type cooled by the pumped liquid. Rotor mounted on greased for life bearings, oversized and selected to guarantee greater noise reduction and durability. Thermal overload motor protection as standard with auto reset 230v / 110v 50hz 1PH only (400v 50hz 3ph requires a panel). Constructed in IEC 2-3 IEC61-69 (EN60335-2-41) standards.

### EXTRAS

Single Phase Pumps fitted with Automatic Float Switch Control. Three Phase Models will require an additional control panel and float system.

## TECHNICAL SPECIFICATION

	BOSS 101
Head up to	14.5m
Flow up to	6.6l/s
Closed valve	15m
Min Sump Dimensions (mm)	H530 x W400 x D400
Outlet size	1½"F BSP
Max immersion depth	10m
Min water level	300mm (auto)
Solids handling	5mm
Max liquid temp*	50°C
Motor Size	0.75 kW
Mains supply	Select
Running current	110V - 17 / 230V - 7 / 400V - 2
Float switch	Yes
Supply cable	10m

### Motor Protection Class

IP68

### Insulation Class

F

### Standard Voltage

110V/230V 1PH 50Hz and 400V 3PH 50Hz

### Motor Rating\*

Continuous running with liquid at 35°C max and pump completely submerged

## MATERIALS

Parts in contact with the pumped liquid	Materials
Pump Body	Anodised Die Cast Aluminium
Support	Anodised Die Cast Aluminium
Impeller	Reinforced Nylon / Fibreglass
Motor Shaft	Stainless Steel AISI 416
Mechanical Seal	Silicon Carbide / Allumina
O Ring	NBR
Filter Grid	Technopolymer
Motor Casing	Stainless Steel AISI 304
Main Cable & Float Cable	HO7 RN-F (PCP Type EM2)

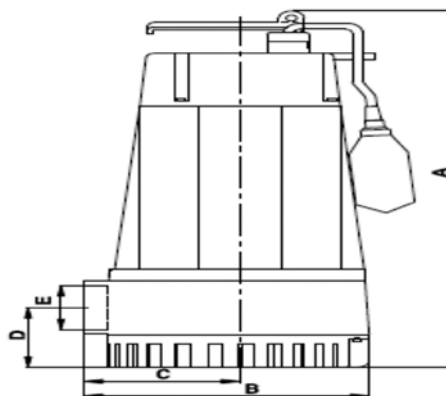

## DIMENSIONS

Model	A	B	C	D	E	Weight Kg
BOSS 101	416	169	92	62	1½"F BSP	11

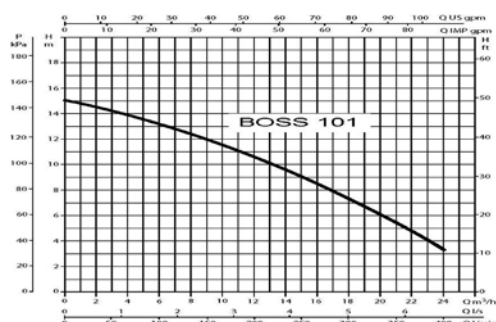

# BOSS 91

## SUBMERSIBLE PUMP FOR WASTE WATER APPLICATIONS

All BOSS Products are supplied with the confidence of high quality and reliability as standard.

**Full service and technical back up.**

	Code
BOSS 91	80630087
BOSS 91	
Head up to	11.4m
Flow up to	6.5l/s
Float Auto	YES
Supply volts	230V

**DURABILITY** - Anti-corrosive full rust proof materials

**OPERATION** - Automatic float switch control

**CAPABILITY** - Solids handling up to 38mm

**INSTALLATION** - Fitted with 10m of mains cable

### APPLICATIONS

Multi purpose submersible electric drainage pump manufactured in rust free anti-corrosion material. Designed for pumping clean and waste water containing solids in suspension up to a maximum of 38mm in diameter. Ideal for cellar drainage and pumping out flooded areas.

### CONSTRUCTION FEATURES OF THE PUMP

Pump body and impeller in technopolymer, motor casing and shaft in stainless steel. Motor shaft triple seal arrangement with Viton V Ring.



### CONSTRUCTION FEATURES OF THE MOTOR

Dry asynchronous sealed motor type cooled by the pumped liquid. Rotor mounted on greased for life bearings, oversized and selected to guarantee greater noise reduction and durability. Thermal overload motor protection as standard with auto reset 230v / 110v 50hz 1PH only. Constructed in IEC 2-3 IEC61-69 (EN60335-2-41) standards.

### EXTRAS

Supplied with a three level hose connection elbow.

## TECHNICAL SPECIFICATION

	BOSS 91
Head up to	11.4m
Flow up to	6.5l/s
Closed valve	12m
Min Sump Dimensions (mm)	H600 x W600 x D600
Outlet size	1½"F BSP
Max immersion depth	10m
Min water level	170mm (auto)
Solids handling	38mm
Max liquid temp	40°C
Motor Size	0.75kW
Mains supply	230V
Running current	5.6A
Float switch	Yes
Supply cable	10m

### Motor Protection Class

IP68

### Insulation Class

F

### Standard Voltage

220-240V 50Hz 1PH

### Motor Rating

Continuous running even with the motor partially submerged

## MATERIALS

Parts in contact with the pumped liquid	Materials
Pump Body	Technopolymer
Impeller	Technopolymer
Motor Shaft	Stainless Steel AISI 416
O-ring Gasket	NBR
O-ring Gasket	NBR
Top Body	Technopolymer
Ceramic Bush	Stainless Steel AISI 416
Upper Bearing Support	Cast Aluminium
Lower Bearing Support	Cast Aluminium
Main Cable & Float Cable	HO7 RN-F (PCP Type EM2)

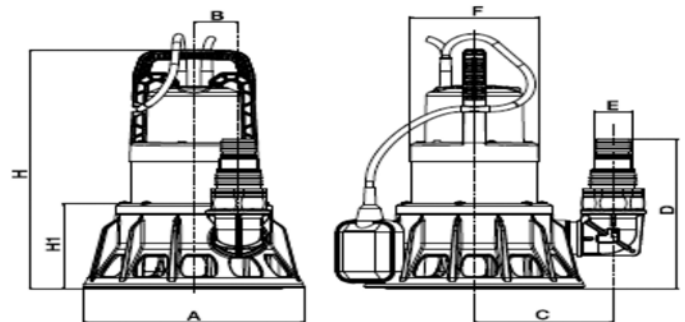

## DIMENSIONS

Model	A	B	C	D	E	F	H	H1	DIA / DNM	Weight Kg
BOSS 91	240	49	150	250	M40	140	400	142	1½"F BSP	5.1

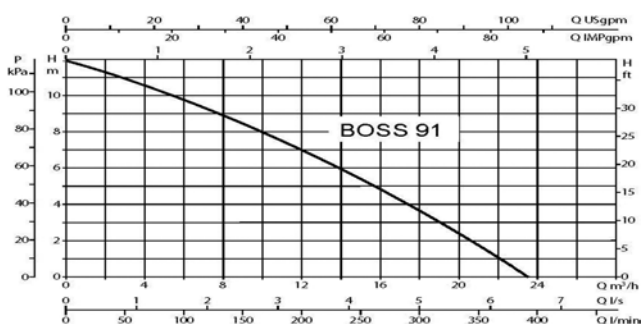

# BOSS 84/104

## SUBMERSIBLE PUMP FOR DIRTY WATER APPLICATIONS

All BOSS Products are supplied with the confidence of high quality and reliability as standard.

**Full service and technical back up.**

	Code
BOSS 84 VOX	80630131
BOSS 104 VOX 110V	80630153
BOSS 104 VOX 230V	80630142
BOSS 104 VOX 400V	80630164

	BOSS 84 VOX	BOSS 104 VOX
Head up to	7m	9m
Flow up to	5.5l/s	6.5l/s
Float Auto	YES	YES
Supply volts	230V	As Above

**DURABILITY** - Ultra strong cast stainless steel impeller

**OPERATION** - Automatic float switch control

**CAPABILITY** - Solids handling up to 50mm

**INSTALLATION** - Fitted with 10m of mains cable

### APPLICATIONS

Stainless steel submersible electric pump with precision cast vortex impeller. Designed for pumping waste water containing solids in suspension up to a maximum of 50mm in diameter.

### CONSTRUCTION FEATURES OF THE PUMP

Pump body, seal housing cover, motor casing and cap with handle made in stainless steel. Precision cast stainless steel impeller. AISI 304 Stainless steel motor shaft. Double mechanical seal arrangement with integral oil chamber (non toxic oil). Seal material in carbon/alumina on the motor end and highly durable carbide/silicon carbide on the pump end.



### CONSTRUCTION FEATURES OF THE MOTOR

Dry asynchronous sealed motor type cooled by the pumped liquid. Rotor mounted on greased for life bearings, oversized and selected to guarantee greater noise reduction and durability. Thermal overload motor protection as standard with auto reset 230v / 110v 50hz 1PH only (400v 50hz 3ph requires a panel). Constructed in IEC 2-3 IEC61-69 (EN60335-2-41) standards.

### EXTRAS

Single Phase Pumps fitted with Automatic Float Switch Control. Three Phase Models will require an additional control panel and float system.

## TECHNICAL SPECIFICATION

	BOSS 84 VOX	BOSS 104 VOX
Head up to	7m	9m
Flow up to	5.5l/s	6.5l/s
Closed valve	7.3m	9.5m
Min Sump Dimensions (mm)	H730 x W700 x D700	H730 x W700 x D700
Outlet size	2" F BSP	2" F BSP
Max immersion depth	10m	10m
Min water level	330mm (auto)	330mm (auto)
Solids handling	50mm	50mm
Max liquid temp*	50°C	50°C
Motor Size	0.55kW	0.75kW
Mains supply	230V	Select
Running current	4.2A	110V - 13 / 230V - 5.13 / 400V - 1.94
Float switch	Yes	Yes
Supply cable	10m	10m

### Motor Protection Class

IP68

### Insulation Class

F

### Standard Voltage

BOSS 84 = 220 -240V 50Hz 1PH

BOSS 104 = 230V / 110V 50Hz 1PH / 400V 50Hz 3PH

### Motor Rating\*

Continuous running even with liquid at 35°C and pump completely submerged

## MATERIALS

Parts in contact with the pumped liquid	Materials
Pump Body	Stainless Steel AISI 304
Impeller	Micro Cast Stainless Steel
Motor Shaft	Stainless Steel AISI 304
Mechanical Seal Pump End	Silicon Carbide / Silicon Carbide
Mechanical Seal Motor End	Carbon / Alumina
Seal Cover	Stainless Steel AISI 304
Motor Casing	Stainless Steel AISI 304
Handle	Stainless Steel AISI 304 With Insulated Rubber Grip
Cable (Mains & Float Switch)	HO7 RN-Fn (PCP Type EM2)

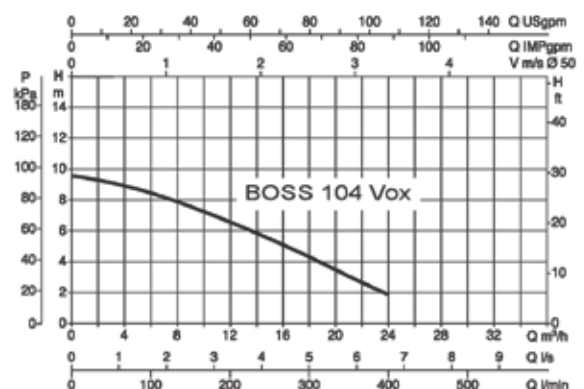
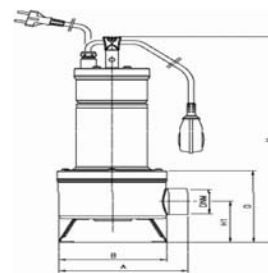

## DIMENSIONS

Model	A	B	D	H	H1	DIA / DNM	Packaging DIM			Weight Kg
							L/A	L/B	H	
BOSS 84 VOX	203	170	172	492	98	2" F BSP	240	600	240	16.3
BOSS 104 VOX	203	170	172	492	98	2" F BSP	240	600	240	17.5

# SPARES & ACCESSORIES



Multi stepped discharge connector 4-step  
1 1/4" BSP F fitting with O-ring x 1 1/4" BSP  
M x D.38 x 1" BSP M x D.25

PUMP MODELS  
**BOSS 36**

CODE  
83080010



Discharge connection elbow 90° 1 1/4"  
BSP M fitting with O-ring x 1 1/4" BSP  
M x with internal 1" BSP F

PUMP MODELS  
**BOSS 21  
BOSS 21V  
BOSS 31  
BOSS 51**

CODE  
83080065



Multi stepped discharge connector 3-step  
1 1/4" BSP M fitting with O-ring x D.38  
x D.32 x D.25

PUMP MODELS  
**BOSS 21  
BOSS 21V  
BOSS 31  
BOSS 51**

CODE  
83080021



Discharge connection elbow 90° 1 1/2" BSP  
M fitting with O-ring x 1 1/2" BSP F

PUMP MODELS  
**BOSS 91  
BOSS 101**

CODE  
83080076



Multi stepped discharge connector 3-step  
1 1/2" BSP M fitting with O-ring x D.50  
x 1 1/4" BSP M x D.40

PUMP MODELS  
**BOSS 91  
BOSS 101**

CODE  
83080032



Discharge connection nipple 1 1/4" BSP M  
fitting with O-ring x 1" BSP M

PUMP MODELS  
**BOSS 21  
BOSS 21V  
BOSS 31  
BOSS 51**

CODE  
83080087



Discharge connection elbow 90° 1 1/4"  
BSP M fitting with O-ring x D.25

PUMP MODELS  
**BOSS 21  
BOSS 21V  
BOSS 31  
BOSS 51**

CODE  
83080043



Discharge connection elbow 90° 1 1/4" BSP  
M fitting with O-ring x D.30

PUMP MODELS  
**BOSS 21  
BOSS 21V  
BOSS 31  
BOSS 51**

CODE  
83080054



# SPARES & ACCESSORIES

## FLEXIBLE GREEN REINFORCED HOSE

Size	Code
1"	83078900
1¼"	83078911
1½"	83078922
2"	83078977
2½"	83078988
3"	83078999



Float switch counter weight (300g) to aid the float switch operation. Made from shockproof polystyrene.

PUMP MODELS
BOSS 84 BOSS 101 BOSS 104 3 PHASE

CODE  
83080120

## BOSS LAYFLAT HOSE KITS

Comprising 10 metres of layflat hose, union tail and knit together with adapter and jubilee clip.

Size	Code
1¼"	83564387
1½"	83564398



BOSS Lifting kit - Footstall and guide rail bracket set.

PUMP MODELS
BOSS 84 BOSS 104

CODE  
83080131



PUMP MODELS
BOSS 84 BOSS 101 BOSS 104 3 PHASE

Float switch complete with 10m of HO7RN-F cable. Can be used to control 3 phase pumps via a suitable panel.

CODE  
83080109



PUMP MODELS
BOSS 21 BOSS 21V BOSS 31 BOSS 51

Float switch complete with 5m of HO7RN-F cable. Can be used to control 3 phase pumps via a suitable panel.

CODE  
83080098



Pipeline & Heating Solutions

## TECHNICAL TEAM

BSS Industrial has an established technical support team offering specialist advice by phone or in person for specific heating applications and solutions.

Tel: 0116 256 7052 Fax: 0116 256 7453 Email: [technicalteam@bssgroup.com](mailto:technicalteam@bssgroup.com)

# SPARES & ACCESSORIES

## UNIVERSAL NON RETURN VALVES

Size	Connections	Type	Weight	BSS Code
½"	Screwed Iron	F x F	0.10	82710286
¾"	Screwed Iron	F x F	0.15	82710297
1"	Screwed Iron	F x F	0.25	82710305
2"	Screwed Iron	F x F	0.71	82710338
2½"	Screwed Iron	F x F	1.26	82710349
3"	Screwed Iron	F x F	1.81	82710360



Spring loaded universal check valve with soft seating and stainless steel spring  
 Maximum working pressure ½" - 1": 16 bar, 1" - 2": 10 bar, 2½" - 3": 8 bar  
 Maximum working temperature: 110°C  
 Other models available on request

## JUBILEE CLIPS

Product Description	Product Code
8-16MM ST/STEEL HOSE CLIP	08701002
12-20MM ST/STEEL HOSE CLIP	08701013
16-25MM ST/STEEL HOSE CLIP	08701035
20-32MM ST/STEEL HOSE CLIP	08701057
25-40MM ST/STEEL HOSE CLIP	08701079
32-50MM ST/STEEL HOSE CLIP	08701109
40-60MM ST/STEEL HOSE CLIP	08701120
50-70MM ST/STEEL HOSE CLIP	08701131
60-80MM ST/STEEL HOSE CLIP	08701142
80-100MM ST/STEEL HOSE CLIP	08701164
110-130MM ST/STEEL HOSE CLIP	08701197
120-140MM ST/STEEL HOSE CLIP	08701205



## Also Available By Request...

### E BOX CONTROL PANEL

A unique control panel that can be used for many applications including draining, filling and boosting.



#### Uses include:

##### Submersible Pumps

- Ideal for filling/draining stations
- Designed for single-phase and three phase pumps
- Working with float switches (max. 5)
- Working with level probes (max. 5)
- Working with depth sensors (0-10V / 4...20mA)
- Amperometric protection
- Exchange of the pumps starting order (each start)

##### Pressure Pumps

- Ideal to drive two pumps booster sets
- Designed for single-phase and three-phase pumps
- Working with pressure switches (max. 4)
- Working with depths (0-10V / 4...20mA)
- Amperometric protection
- Exchange of the pumps starting order (each start)

#### Technical Information

Model	Voltage (50HZ)	Starting	P2 Nominal kW x 2	HP x 2	MAX Current A	No. Connectable Floats	No. Connectable Pumps
E-Box 2D M/T	1 x 230V 3 x 400V	Direct	2.2 5.5	3 7.5	12 + 12	2 - 3 - 4	1 / 2
E-Box 2D 40uF	1 x 230V	Direct	2.2	3	12 + 12	2 - 3 - 4	1 / 2

For more information, please contact AMS Technical Support on 0870 609 2101.

# RANGE SUMMARY

MODEL	Flow Up To	Head Up to	Closed Valve	Phase	Motor Size	Solids Handling	Max Fluid Temp (°C)*	Outlet Size	Supplied With
BOSS 21 Code 80630010	1.9l/s	5m	5.5m	1PH	0.22 KW	5mm	35°	1¼" BSP F	ELBOW D.25
BOSS 21 VOX Code 80630021	3l/s	6.5m	7m	1PH	0.44 KW	20mm	35°	1¼" BSP F	Elbow D.30
BOSS 36 110 V Code 80630054	3.1l/s	8.8m	9m	1PH	0.4 KW	5mm	40°	1¼" BSP F	4-Step Fitting
BOSS 36 Code 80630065	3.1l/s	8.8m	9m	1PH	0.4 KW	5mm	40°	1¼" BSP F	4-Step Fitting
BOSS 31 110 V Code 80630032	2.5l/s	6.3m	7m	1PH	0.25 KW	10mm	50°	1¼" BSP F	3-Step Fitting
BOSS 31 Code 80630043	2.5l/s	6.3m	7m	1PH	0.25 KW	10mm	50°	1¼" BSP F	3-Step Fitting
BOSS 51 Code 80630076	3.75l/s	9.3m	10m	1PH	0.45 KW	10mm	50°	1¼" BSP F	3-Step Fitting
BOSS 101 110V Code 80630120	6.6l/s	14.5m	15m	1PH	0.75 KW	5mm	50°	1½" BSP F	Bare
BOSS 101 Code 80630098	6.6l/s	14.5m	15m	1PH	0.75 KW	5mm	50°	1½" BSP F	Bare
BOSS 101 3PH Code 80630109	6.6l/s	14.5m	15m	3PH	0.75 KW	5mm	50°	1½" BSP F	Bare
BOSS 91 Code 80630087	6.5l/s	11.4m	12m	1PH	0.75 KW	38mm	40°	1½" BSP F	Elbow 1 1/2"
BOSS 84 VOX Code 80630131	5.5l/s	7m	7.3m	1PH	0.75 KW	50mm	50°	2" BSP F	Bare
BOSS 104 110 V Code 80630153	6.5l/s	9m	9.5m	1PH	0.75 KW	50mm	50°	2" BSP F	Bare
BOSS 104 1PH Code 80630142	6.5l/s	9m	9.5m	1PH	0.75 KW	50mm	50°	2" BSP F	Bare
BOSS 104 3PH Code 80630164	6.5l/s	9m	9.5m	3PH	0.75 KW	50mm	50°	2" BSP F	Bare

\*Continuous running at 35°C

## PUMPS CURVES

### CLEAR WATER PLASTIC PUMPS

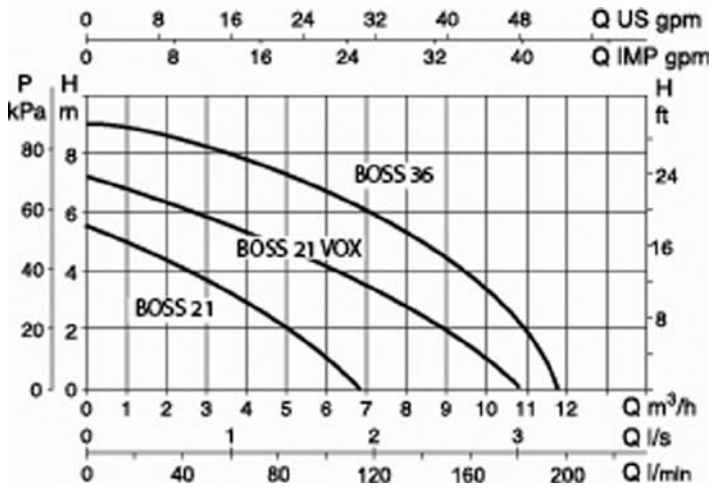

### CLEAR WATER METAL PUMPS

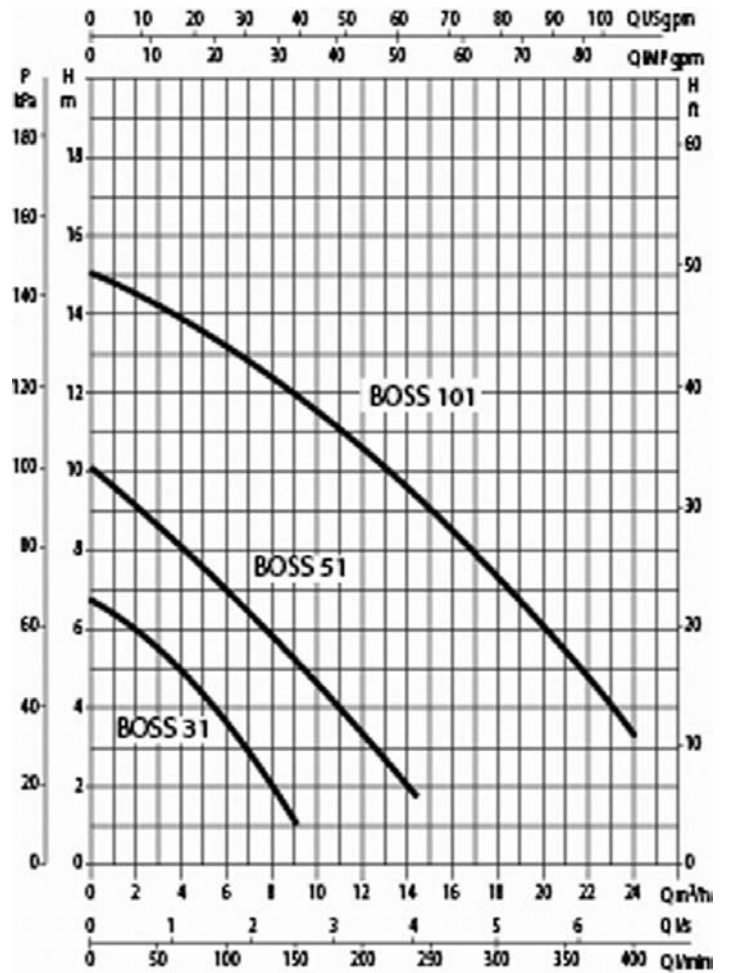

### DIRTY WATER PUMPS

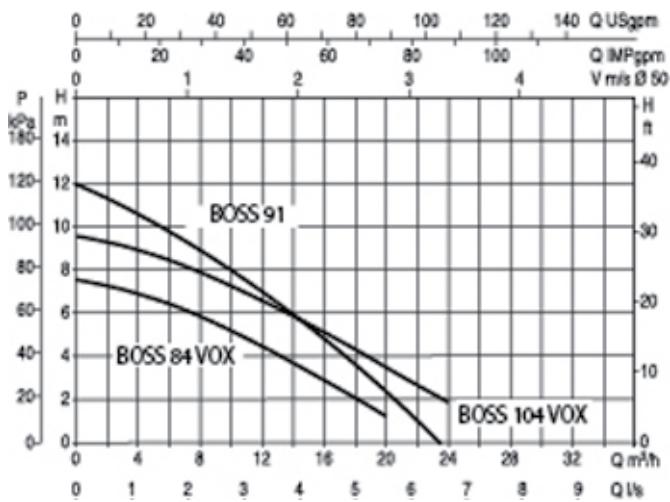

If you require any more information regarding the BOSS Sump Pump Range, please contact BSS TECHNICAL on 0116 256 7052 or AMS PUMPS TECHNICAL SUPPORT on 0870 609 2101.

# AMS Pumps

**BSS** | Specialist in Pumping Systems

**A specialist brand within BSS Industrial, AMS Pumps have nearly 50 years of experience in providing pump products and aftersales services for a multitude of applications including hygienic food processing.**

**With a comprehensive range of products available from leading manufacturers, AMS are committed to offering professional technical advice on any aspect of pump sizing and suitability for proposed applications.**

**Staffed by a dedicated team of experts, AMS Aftersales offer a complete range of services to customers including:**

- Spares
- Repairs
- Commissioning
- Servicing and Service Contracts

**More information can be found out by contacting AMS directly on the details below:**

**AMS National Technical Sales Centre**  
(new pumps and technical enquiries)

**T: 0870 609 2101 | E: [amspumps@bssgroup.com](mailto:amspumps@bssgroup.com)**

**AMS Aftersales (pump repairs, commissioning, spares)**

**T: 0870 850 3886 | E: [amsse@bssgroup.com](mailto:amsse@bssgroup.com)**



**AMS Pumps**  
Specialist in Pumping Systems

**AMS Aftersales**  
Specialists in Pump Aftersales & Spares

# Other literature available from BSS Industrial...

All BSS literature is available to download from our website,  
and selected brochures can be ordered online.



BSS Industrial Pumps



BOSS Heating & Hot Water Services Guide



BSS Site Support Binder



BSS Rainwater Product Guide



BSS Drainage Product Guide



BOSS Valves Binder

## Grab your copy now!

Available to order online at [www.bssindustrial.co.uk](http://www.bssindustrial.co.uk) or from your local branch.

## BSS Branches

### SCOTLAND, IRELAND & NORTH REGION

**BSS Aberdeen**  
Unit 5a, South Middleton Base  
Greenwell Road, East Tullos  
Aberdeen AB12 3AX  
Tel: 01224 292929  
E: 1550.sales@bssgroup.com

**BSS Belfast**  
36-38 Duncrue Road  
Duncrue Industrial Estate  
Belfast, Northern Ireland BT3 9BP  
Tel: 028 9078 4000  
E: 1910.sales@bssgroup.com

**BSS Drainage Bellshill**  
Unit 4, 8 Melford Road  
Righead Industrial Estate  
Bellshill ML4 3LR  
Tel: 01698 740440  
E: drainage1510@bssgroup.com

**BSS Carlisle**  
Unit 2A, Port Road Business Park  
Carlisle CA2 7AJ  
Tel: 01228 517600  
E: 1780.sales@bssgroup.com

**BSS Dublin**  
White Heather Industrial Estate  
301 South Circular Road  
Dublin 8  
Tel: 00 353 14 165100  
E: 1930.sales@bssgroup.com

**BSS Dundee**  
Unit 1-3, Rutherford Road  
Dryburgh Industrial Estate  
Dundee DD2 3XH  
Tel: 01382 823700  
E: 1580.sales@bssgroup.com

**BSS Edinburgh**  
Unit 2A, Pentland Industrial Estate  
Loanhead, Midlothian  
EH20 9QH  
Tel: 0131 440 5900  
E: 1560.sales@bssgroup.com

**BSS Glasgow**  
Unit A, 91 Vermont Street  
Kinning Park Glasgow G41 1LU  
Tel: 0141 418 4444  
E: 1540.sales@bssgroup.com

**BSS Hull**  
Copenhagen Road  
Sutton Fields Industrial Estate  
Hull, East Yorkshire HU7 0YH  
Tel: 01482 625800  
E: 1610.sales@bssgroup.com

**BSS Leeds**  
Turnkey Park Estate  
Royds Lane  
Leeds LS12 6AD  
Tel: 0113 203 2203  
E: 1350.sales@bssgroup.com

**BSS Newcastle**  
Sanderson Street  
Newcastle-upon-Tyne NE4 7PJ  
Tel: 0191 256 5100  
E: 1650.sales@bssgroup.com

**BSS Sheffield**  
Unit 15, Oakham Drive  
Parkwood Industrial Estate  
Sheffield S3 9QX  
Tel: 0114 289 3900  
E: 1460.sales@bssgroup.com

**BSS Stockton**  
Teesway, North Tees  
Industrial Estate  
Stockton on Tees  
TS18 2RS  
Tel: 01642 665500  
E: 1660.sales@bssgroup.com

**Warrens Leeds**  
Unit 4B, Olympia Industrial Estate,  
Gelder Lane  
Leeds LS12 6AL  
Tel: 0113 224 6500  
E: salesleeds@awarrens.co.uk

### CENTRAL REGION

**BSS Birmingham Central**  
Unit 49, Gravelly Industrial Park  
Tyburn Road, Erdington  
Birmingham B24 8TG  
Tel: 0121 322 0370  
E: 1810.sales@bssgroup.com

**BSS Birmingham Oldbury**  
Unit 1a, Junction Two Industrial  
Estate  
Demuth Way, Oldbury  
West Midlands B69 4LT  
Tel: 0121 541 1666  
E: 1670.sales@bssgroup.com

**BSS Birmingham Smethwick**  
Units 2 & 4 Crystal Drive  
Sandwell Business Park  
Smethwick  
West Midlands B66 1QG  
Tel: 0121 552 6000  
E: 1220.sales@bssgroup.com

**BSS Cambridge**  
Unit 3, Rosemary Lane  
Cambridge CB1 3LQ  
Tel: 01223 404040  
E: 1840.sales@bssgroup.com

**BSS Colchester**  
Unit 6, Smeaton Close  
Severalls Industrial Park  
Colchester, Essex CO4 9QY  
Tel: 01206 754720  
E: 1200.sales@bssgroup.com

**BSS Coventry**  
Unit 17, 219 Torrington Avenue  
Coventry, West Midlands  
CV4 9HN  
Tel: 024 7669 4744  
E: 1490.sales@bssgroup.com

**BSS Derby**  
Riverside Road,  
Pride Park  
Derby DE24 8HH  
Tel: 01332 685600  
E: 1450.sales@bssgroup.com

**BSS Grimsby**  
Appian Way, Europa Park  
Grimsby DN31 2FD  
Tel: 01472 265100  
E: 1680.sales@bssgroup.com

**BSS Leicester**  
66 Cobden Street  
Leicester LE1 2LB  
Tel: 0116 242 7800  
E: 1440.sales@bssgroup.com

**BSS Lincoln**  
Units 3/4 Crofton Drive  
Allenby Industrial Estate  
Lincoln LN3 4NR  
Tel: 01522 565700  
E: 1480.sales@bssgroup.com

**BSS Liverpool**  
82/94 Great Howard Street  
Liverpool L3 7AX  
Tel: 0151 482 2500  
E: 1330.sales@bssgroup.com

**BSS Manchester**  
Unit 1, Columbus Way,  
off Broadway  
Salford, Manchester M50 1UU  
Tel: 0161 888 6464  
E: 1340.sales@bssgroup.com

**BSS Northampton**  
Riverside Way  
Bedford Road  
Northampton NN1 5NX  
Tel: 01604 251400  
E: 1410.sales@bssgroup.com

**BSS Norwich**  
Unit 13, Alston Road  
Hellesdon Park Industrial Estate  
Norwich, Norfolk NR6 5DS  
Tel: 01603 253200  
E: 1710.sales@bssgroup.com

**BSS Nottingham**  
Unit 3, Longwall Avenue  
Queens Drive Industrial Estate  
Nottingham NG2 1NA  
Tel: 0115 943 5900  
E: 1430.sales@bssgroup.com

**BSS Oldham**  
Constantine Street, Oldham  
Lancashire OL4 3AD  
Tel: 0161 624 4621  
E: 1640.sales@bssgroup.com

**BSS Peterborough**  
Unit 2a, Centurion Business Centre  
Sturrock Way, Bretton  
Peterborough PE3 8YB  
Tel: 01733 336000  
E: 1470.sales@bssgroup.com

**BSS Preston**  
Unit 1 & 2, Brookfield Street  
Preston PR1 1NR  
Tel: 01772 557800  
E: 1310.sales@bssgroup.com

**BSS Stoke-on-Trent**  
Unit 6 & 7 Etruria Trading Estate  
Etruria Way, Basford,  
Stoke-on-Trent ST4 6JQ  
Tel: 01782 382382  
E: 1360.sales@bssgroup.com

**BSS Wigan**  
Unit 2, Lockflight Buildings  
Wheatlea Industrial Estate  
Wheatlea Road,  
Wigan WN3 6XP  
Tel: 01942 405540  
E: 1720.sales@bssgroup.com

**BSS Wirral**  
Rossmore Road East  
Rossmore Industrial Estate  
Ellesmere Port, Wirral  
Cheshire CH65 3DD  
Tel: 0151 348 5400  
E: 1320.sales@bssgroup.com

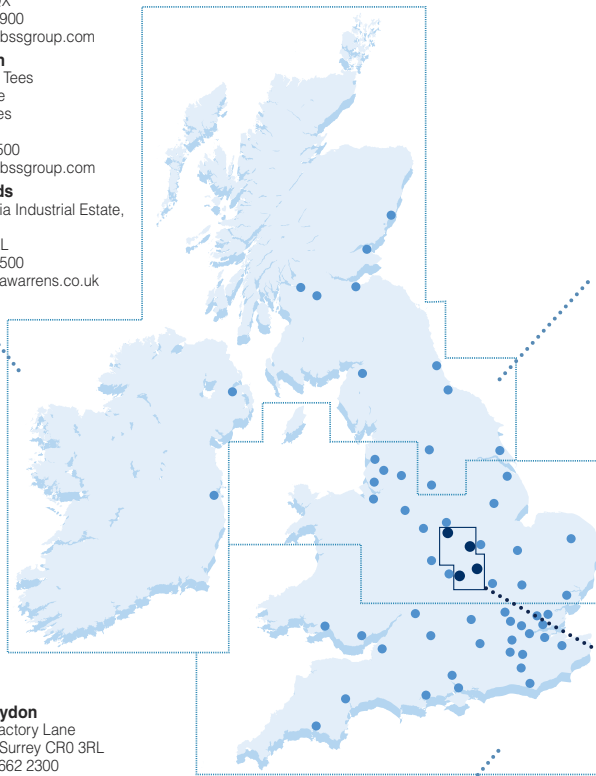

### SOUTHERN REGION

**BSS Borehamwood**  
Chester Road, Borehamwood  
Hertfordshire WD6 1LT  
Tel: 020 8327 4100  
E: 1500.sales@bssgroup.com

**BSS Bournemouth**  
Unit 3B, Broom Road Business Park  
Broom Road  
Poole BH12 4PA  
Tel: 01202 711300  
E: 1400.sales@bssgroup.com

**BSS Brentford**  
Transport Avenue  
Brentford, Middlesex TW8 9HF  
Tel: 020 8232 2727  
E: 1110.sales@bssgroup.com

**BSS Bristol**  
Albert Road, St Philips  
Bristol BS2 0BS  
Tel: 0117 972 7900  
E: 1250.sales@bssgroup.com

**BSS Drainage Canning Town**  
Unit 1 Pylon Industrial Estate  
Cody Road, Canning Town  
London E16 4SP  
Tel: 020 7540 5260  
E: drainage1370@bssgroup.com

**BSS Cardiff**  
Unit 1 Trident Trade Park  
Glass Avenue  
Cardiff CF24 5EP  
Tel: 029 2043 2400  
E: 1280.sales@bssgroup.com

**BSS Chessington**  
Oakcroft Road  
Chessington Industrial Estate  
Chessington, Surrey KT9 1RH  
Tel: 020 8974 3800  
E: 1950.sales@bssgroup.com

**BSS Crawley**  
12A Demvale Trade Park  
Haslett Avenue East  
Crawley RH10 1SS  
Tel: 01293 610170  
E: 1390.sales@bssgroup.com

**BSS Croydon**  
Unit 34, Factory Lane  
Croydon, Surrey CR0 3RL  
Tel: 020 8662 2300  
E: 1120.sales@bssgroup.com

**BSS Dartford**  
Unit 11, Orbital One  
Green Street, Green Road  
Dartford, Kent DA1 1QG  
Tel: 01322 289039  
E: 1570.sales@bssgroup.com

**BSS Exeter**  
Unit 6 Otter Court  
Manaton Close  
Matford Business Park  
Exeter EX2 8PF  
Tel: 01392 457500  
E: 1240.sales@bssgroup.com

**BSS Gloucester**  
Unit C1, Eastbrook Road  
Gloucester GL4 3DB  
Tel: 01452 872200  
E: 1230.sales@bssgroup.com

**BSS Kings Cross**  
Unit 2, 1 Brewery Road Islington  
London N7 9JQ  
Tel: 020 7619 7600  
E: 1160.sales@bssgroup.com

**BSS Lewes**  
Unit 5, Southdown  
Business Park, Brooks Road  
Lewes, East Sussex BN7 2FB  
Tel: 01273 485000  
E: 1190.sales@bssgroup.com

**BSS London Docklands**  
Units 6 & 7,  
Thomas Road Industrial Estate,  
Limehouse, London E14 7BN  
Tel: 020 7531 3900  
E: 1920.sales@bssgroup.com

**BSS Luton**  
1 Trojan Court, Laporte Way  
Luton, Bedfordshire LU4 8RJ  
Tel: 01582 875600  
E: 1420.sales@bssgroup.com

**BSS Maidstone**  
Unit 5, Wood Close  
Quarry Wood Industrial Estate  
Aylesford, Kent ME20 7UB  
Tel: 01622 713600  
E: 1850.sales@bssgroup.com

**BSS Oxford**  
Unit C Taurus, Peterley Road  
Horspath Industrial Estate  
Cowley, Oxford OX4 2TZ  
Tel: 01865 398870  
E: 1630.sales@bssgroup.com

**BSS Plymouth**  
Block G, St. Modwen Road  
Parkway Industrial Estate  
Plymouth, Devon PL6 8LH  
Tel: 01752 675300  
E: 1260.sales@bssgroup.com

**BSS Portsmouth**  
Unit D4 Discovery  
Voyager Park, Portfield Road  
Airport Industrial Estate  
Hilsea, Portsmouth PO3 5FL  
Tel: 02392 658740  
E: 1820.sales@bssgroup.com

**BSS Reading**  
Units A2 & A3, Worton Drive  
Worton Grange  
Industrial Estate  
Reading RG2 0TG  
Tel: 0118 923 8900  
E: 1180.sales@bssgroup.com

**BSS Romford**  
King George Close  
Eastern Avenue West  
Romford, Essex RM7 7PS  
Tel: 01708 771800  
E: 1130.sales@bssgroup.com

**BSS Southampton**  
Unit 1a, Parham Drive  
Boyatt Wood Trading Estate  
Eastleigh, Hampshire SO50 4NU  
Tel: 023 8068 3700  
E: 1140.sales@bssgroup.com

**BSS Swansea**  
Unit 2, Century Park  
Swansea Enterprise Park  
Swansea SA6 8RP  
Tel: 01792 762300  
E: 1290.sales@bssgroup.com

**BSS Swindon**  
Unit 4A, Euroway Industrial Estate  
Blagrove  
Swindon SN5 8YW  
Tel: 01793 601500  
E: 1210.sales@bssgroup.com

**BSS Wandsworth**  
Unit 5, 307-309 Merton Road  
Wandsworth  
London SW18 5JS  
Tel: 020 8877 9191  
E: 1760.sales@bssgroup.com

**Warrens London**  
Unit 5, New England Trading Estate  
Gascoigne Road  
Barking IG11 7NZ  
Tel: 020 8477 8888  
E: saleslondon@awarrens.co.uk

### HEAD OFFICE

Fleet House, Lee Circle, Leicester LE1 3QQ  
Tel: 0116 262 3232 Fax: 0116 253 1343  
Email: reception@bssgroup.com

### NATIONAL DISTRIBUTION CENTRE

Buccaneer Way, Magna Park,  
Lutterworth LE17 4YZ  
Tel: 01455 551000 Fax: 01455 556 079

### NATIONAL TUBE DISTRIBUTION CENTRE

Ashcroft Way, Cross Point Business Park,  
Coventry CV2 2TU  
Tel: 024 7662 5700 Fax: 024 7662 5701

### BULWELL NATIONAL DISTRIBUTION CENTRE

Martin Close, Blenheim Industrial Estate,  
Bulwell, Nottingham NG6 8UW  
Tel: 0115 927 8288 Fax: 0115 973 9543