



BOSS Mini Mechanical Pressurisation Equipment

Mini Models (MX1-3HL, MX2-3HL)

Operation & Maintenance Manual

Rev 2.1



Customer Details

Please fill in information future reference:

Company:	<input type="text"/>	Contact:	<input type="text"/>
Address:	<input type="text"/>	Tel No:	<input type="text"/>
		Fax No:	<input type="text"/>
Post Code:	<input type="text"/>	E-mail:	<input type="text"/>

Equipment Details

Details of model and serial number may be found on the label

Model:	<input type="text"/>	Serial No:	<input type="text"/>
Purchase date:	<input type="text"/>	Purchase From:	<input type="text"/>

Note:

It is highly recommended to have this equipment commissioned by a BOSS approved engineer. Any damage or loss incurred through incorrect commissioning by an unapproved engineer will not be covered by the warranty. If you wish for BOSS to arrange this please contact us. (See contact details)

Please see the warranty section for details.

Remember to fill in details for future use for re-commission unit.

Do not use this equipment to fill a system, use a WRAS approved filling loop for initial filling. Mechanical equipment does not have the required electrical monitoring for ethical system filling operations. Under no circumstances must mini units be used to fill a system of any size. A suitable safety relief valve must be fitted to the system.

Commissioning Record

FILL IN RECORD TO VALIDATE WARRANTY OF PRESSURISATION UNIT

Site Reference:

PU Reference: Date Commissioned: / /

Engineer Name:

Company:

PUMP CONTROL PRESSURE SWITCH

RANGE:
DIFFERENTIAL:

PUMPS NUMBER: 1 / 2 Delete as appropriate

HIGH/LOW PRESSURE SWITCH

HIGH PRESSURE - CUT OUT
LOW PRESSURE - CUST IN
LOW PRESSURE - DIFF

NOTES:

Engineer Signature: Date: / /

Customer Signature: Date: / /

Commissioning certificate can be obtained please contact BSSrepresentative

Contents

Customer & Equipment details	2
Commission Record	3
About this Manual	
Where to find more Information	5
Equipment Overview	
Principal of Operation	6
Important Information	
Environment	7
Safety	7
Application	7
Cold Pressures	7
Installation	
Pipe Connections	8
Typical Installation Diagram	8 - 9
Flow Restrictors	9 - 10
Mini Clearance and Connection Requirements	11
Electrical Power Supply	12
Commissioning	
Pre-Commissioning Checklist	13
Commissioning	14 - 16
Hydraulic Commissioning	17 - 18
Maintenance	
Maintenance information	19
Wiring	
Wiring Diagram	20
Spares	
Mini Models (MX1-3HL, MX2-3HL)	21 - 22
Troubleshooting	
Service Log	24 - 25
Warranty Information	26

About this Manual

This Operation and Maintenance Manual contains all the necessary information to install, commission, operate and maintain Flexfiller pressurisation equipment.

It is recommended to read all parts of this manual before undertaking any work on the equipment.

Conventions used in this Manual

This manual makes use of symbols to identify key pieces of information. Please take note of the following symbols and their meaning:



DANGER – Important safety related information intended to prevent injury and/or damage to the equipment, system or property.



CAUTION - Important information intended to prevent damage to the equipment, system or property.



IMPORTANT - Important information intended to ensure that the equipment functions correctly.



USEFUL – Useful information which may be helpful, but is not necessarily required for the unit to function correctly.

Typography

This manual makes use of different typography to identify different types of information.

<i>Italics</i>	Key words and phrases
(Round Brackets)	Used to identify a button on the digital controller
[Square Brackets]	A parameter on the digital controller
<Inequality Symbols>	A message/fault code displayed on the digital controller

Where to find more Information

For further information please visit the BSS Website at the following URL:

www.bssindustrial.co.uk

Alternatively, please contact the BSS technical team using the details below:

Phone: 0116 262 3232
Fax: 0116 253 1343
Email: equiries@bssgroup.com

Equipment Overview

The function of this pressurisation unit is to provide a means of automated water top-up to sealed heating and cooling systems. The equipment is designed to provide periodic water top-up to compensate for minor losses in system pressure (e.g. slow leaks, air venting, etc.).



This equipment is not designed to cope with sudden losses of system pressure (e.g. manual draining) or major water losses (e.g. large leaks). The equipment is also not intended to be used for water boosting applications.

Principal of Operation

The following schematic shows the internal arrangement of a pressurisation unit:

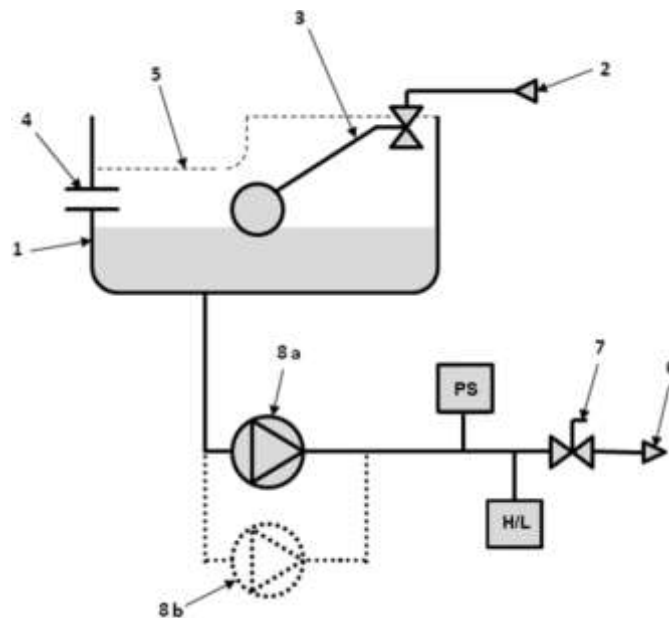

The pressurisation unit is fitted with a break tank (1) which is filled from the mains water supply (2) via a float operated valve (3). The break tank is fitted with an overflow (4) in case the break tank overfills, and a weir overflow (5) in case the primary overflow fails.

The pressurisation unit is connected into the heating system (6) via an isolation valve (7).

The pressure switch (PS) monitors the system pressure. High/Low Switch (H/L) is connected to the boiler to control the cut in and cut out of boiler pressure

If the pressure sensor detects a drop in pressure, the pump (8a or 8b) will pump water from the break tank into the system. Once the required pressure has been reached, the pump will stop.

On twin pump models, a second pump (8b) is provided. On mechanical unit you can select either pump with a pump selection switch

IMPORTANT INFORMATION

Environment

- It is not anticipated that this equipment will be exposed to adverse environmental conditions without additional protection.
- Site the equipment in a frost free area.
- Ensure that 100 mm of clear access is available around the equipment with 500 mm clear access at the front.
- Flush the mains water supply pipe before connection to this equipment.
- An inline filter must be fitted to the inlet of the equipment if the mains water supply is suspected to contain debris.
- Please refer to BS 7074 for the installation code of practice.
- Do not use this equipment to fill a system unless otherwise stated; it is designed to 'top-up' a system in the event of pressure loss due to deaerating and minor system leakage.

Safety

- Electrical installation must be carried out by a competent person
- WARNING – LIVE TERMINALS WITHIN THIS EQUIPMENT
- Isolate the equipment before removing any covers
- **Do Not** make any electrical adjustments to the equipment unless it is isolated from the mains electrical supply
- **Do Not** operate with the electrical covers removed
- **Do Not** alter any internal pipe-work, this equipment is tested prior to Dispatch.
- **Do Not** obstruct and ventilation fans or apertures
- **Check** supply voltage and overload protection is correct

Application

Automatic make up and pressurisation unit for sealed heating and cooling systems.
This equipment is designed to work in conjunction with an appropriately sized expansion vessel.

Cold Pressures

The unit is fully adjustable to provide a minimum static pressure of 0.7 bar(g) the maximum static pressure is dependent on the pump set fitted. If in any doubt please contact your product supplier.

Installation



This pressurisation unit is not designed to be installed in an outdoor environment. The unit must be installed in a frost free environment, away from precipitation and water sprays/jets. If there is a risk of flooding, the unit must be installed on a raised plinth.



Please refer to the appropriate datasheet for the maximum working pressure and temperature of the pressurisation unit. The conditions at the point of connection to the system must not exceed these values.

Pipe Connections



To avoid damaging the float valve, the mains water supply pipe must be flushed before connection to the pressurisation unit.



All pipe connections must be made with appropriate jointing compound/PTFE tape. If PTFE tape is used, care must be taken to ensure that the tape does not obstruct the orifice of the fitting.



Non-return valves, pressure reducing valves and RPZ valves must not be installed between the pressurisation unit and the heating/cooling system. These devices will prevent the pressure sensor from reading the system pressure.



The pressurisation unit and expansion vessel should be connected to the system at the same point, to provide a neutral pressure reading. This point of connection should be in the system return, on the suction side of the circulation pump.

Typical Installation Diagram

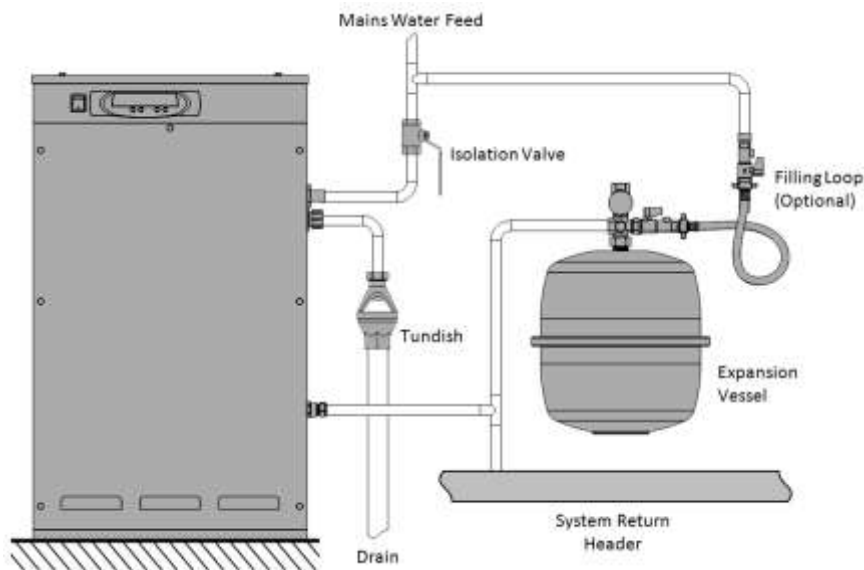

Installation of mini mechanical units

- Remove the appropriate coverings.
- Ensure that the float valve is set to its lowest position.
- All pipework connections are to be made with appropriate proprietary jointing compound. PTFE is not permitted.
- Connect the overflow pipework.
- Connect the mains water pipework.
- Connect the system pipework.
- Open the system isolation valve.
- Check the break tank internal pump suction filter is present and clear.
- Connect the electrical supply to the fused connection block / fused spur as appropriate.
- Set the range and Diff on the pressure control switch.
- Connect the boiler to the boiler interlock connection block, High / Low Switches

Flow Restrictors



Pressurisation equipment fitted with a plastic, side-entry torbeck valve must be fitted with a filter and – depending on the mains water pressure – a flow restrictor. Failure to do this may result in damage to the equipment.

Two different flow restrictors are supplied with the equipment, both of which include an integral filter. The selection of the appropriate flow restrictor is based on the maximum mains water pressure at the point of installation. Please refer to the following table for selection.

Mains Water Pressure	Requirement
Below 1 Bar	No Restrictor. Install Filter Only
1 – 4 Bar	Low Pressure Restrictor (coloured)
Above 4 Bar	High Pressure Restrictor (white)

If no restrictor is required, the filter must be removed from one of the restrictors and installed on its own. The following diagram shows how to remove the filter:

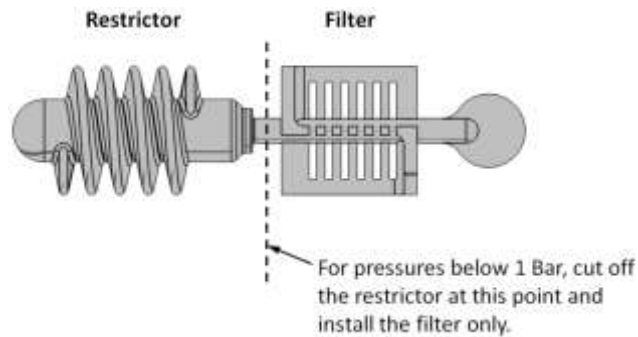

To install the flow restrictor/filter, hold it by the tab and push it into the opening of the float valve connection, as shown in the diagram below:

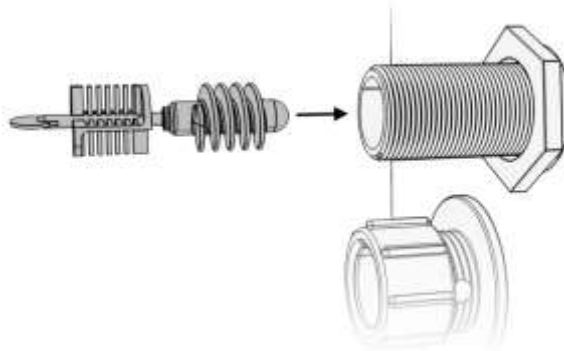

Mini MX-HL Clearance and Connection Requirements

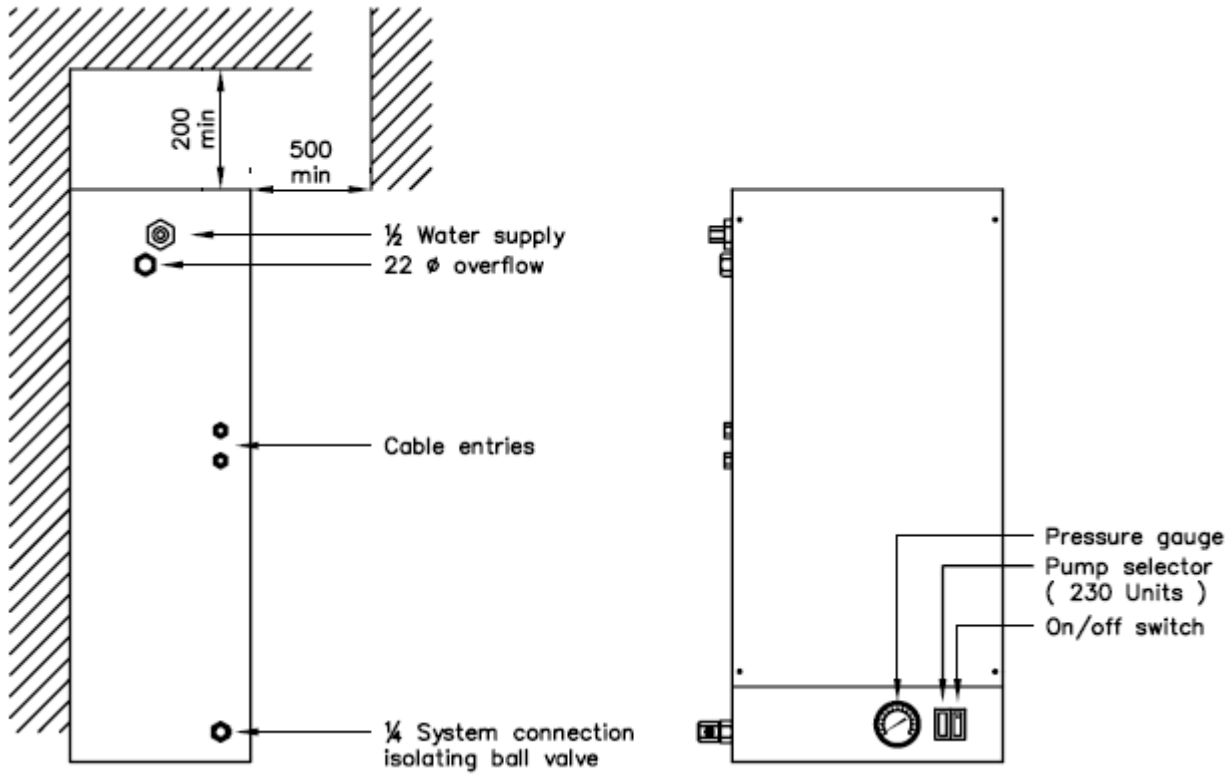

Connection	Size	Notes
Mains Water Feed	1/2" BSP M	An isolation valve must be installed on the mains water feed for servicing.
Break Tank Overflow	22 mm	Guidance on drainage requirements should be obtained from the local water authority.
System Connection	1/4" BSP F	The pressurisation unit and expansion vessel should be connected to the system at the same point. The point of connection should be in the system return, on the suction side of the circulation pump. Non-return valves, pressure reducing valves and RPZ valves must not be used.

Electrical Power Supply



This equipment must be electrically isolated before removing the covers. Cables connected to the volt free contacts may be supplied from another source and may remain live after the unit is isolated. These must be isolated elsewhere.



All electrical connections must be carried out by a suitably qualified and competent person.

The mains power supply to the pressurisation unit must be connected into the fused terminal block as shown below:

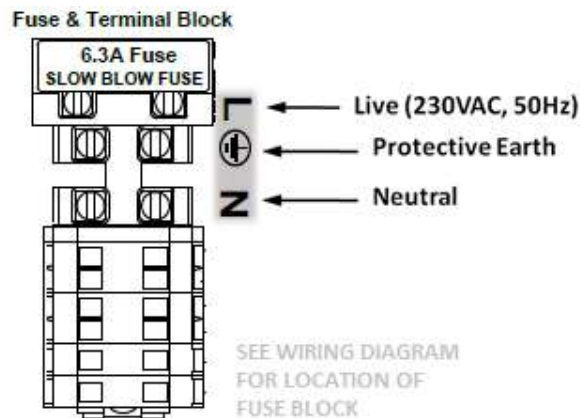

On some larger models, the fused terminal block is replaced by a fused spur. If this is the case, the power supply must be connected into the fused spur, as shown below:

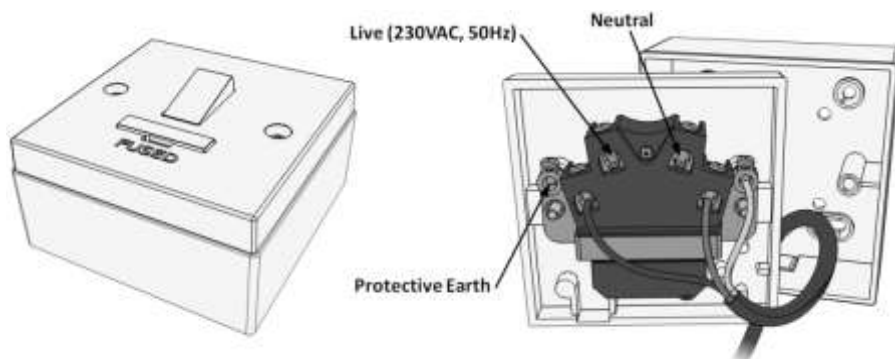

It is recommended to supply power to the pressurisation unit via a lockable isolator. This should be installed within 2m of the equipment.



This equipment can be damaged by the high voltages produced by electrical installation testing equipment. When performing electrical installation tests, the equipment must be isolated from the supply.

Commissioning



It is highly recommended to have this equipment commissioned by a BOSS approved engineer. Any damage or loss incurred through incorrect commissioning by an unapproved engineer will not be covered by the warranty.

Pre-Commissioning Checklist



The following conditions must be met before starting the commissioning process. Failure to meet these conditions may result in injury or damage to the equipment, system and property.

Equipment is sited in a frost free area, away from precipitation and water sprays/jets

All necessary pipe/electrical connections have been made to a satisfactory standard

The temperature and pressure at the point of connection are within the operating limits of the pressurisation unit.

The heating/cooling system is fitted with a safety valve and expansion vessel



The following conditions must be met for the pressurisation unit and heating/cooling system to function correctly. If these conditions have not been met, it is not advisable to proceed with the commissioning process.

The system connection has been made into the system return header/pump suction

There are no non-return valves, pressure reducing valves or RPZ valves installed between the pressurisation unit and the heating/cooling system

The expansion vessel is pre-charged to the correct pressure (equal to fill pressure)

Do not use this equipment to fill a system, use a WRAS approved filling loop for initial filling. Mechanical equipment does not have the required electrical monitoring for ethical system filling operations. Under no circumstances must mini units be used to fill a system of any size. A suitable safety relief valve must be fitted to the system.

The heating/cooling system is filled and pressurised to the required cold fill pressure, with the water at ambient temperature (approximately).

Commissioning

- Commissioning must be carried out by a trained and competent person.
- Close the system connection valve. (isolation valve)
- Turn on the unit, the current pump pressure is shown on the mounted gauge.
- Adjust the pressure (Cold fill pressure) using the pressure switch (black screw)
- When the pressure shown on the mounted gauge is to the desired cold fill pressure open the system connection valve.
- Once open to the system minor further adjustment may be required.
- If possible, bleed any residual air from the pumps. Caution do not attempt this operation unless you are trained to do so.
- Note - The cold pressure of the system should be set to at least 0.2 bar(g) above the static height of the system, with a minimum permissible set pressure of 0.7 bar(g).
- Note - The high and low pressure switches are pre-set for systems with an anticipated cold fill pressure of 1.0 bar(g), for other system pressures adjustment of the high and low switches may be required.

Pressure Switch Settings (Pressurisation control)

The Pressure switch has two settings:

- Range setting

The pressure range within which the unit will give a signal (contact changeover).

- Differential

The difference between contact changeover on rising and falling pressure.

The differential is a condition for stable automatic plant operation.



To change the pressure gauges turn the screw slightly.

Black screw for Range setting

Silver screw for Differential (Diff)

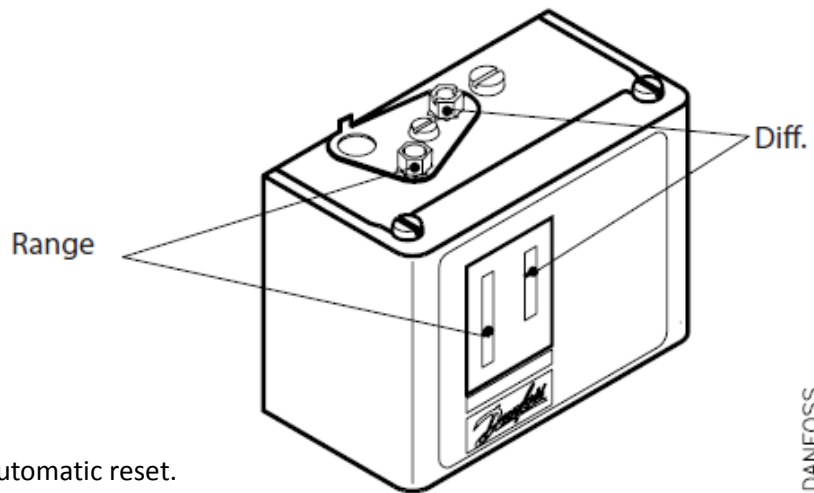

DANFOSS
A60-876.12

Pressure setting for switches with automatic reset.

1. Set the cut-in pressure on the "CUT-IN" scale (range scale),
2. Set the differential on the "DIFF" scale.

High and Low Pressure Settings (Boiler control)

The high pressure switch is pre-set to cut out at 3.0 bar(g) and will not re-set until the system pressure has dropped to 2.0 bar(g).

The low pressure switch is pre-set to cut out at 0.5 bar(g) and will not re-set until the system pressure has increased to 0.9 bar(g).

These switches can be adjusted using the appropriate nut on top of the switch housing. Note this switch is for boiler cut out



Low pressure (LP) side setting

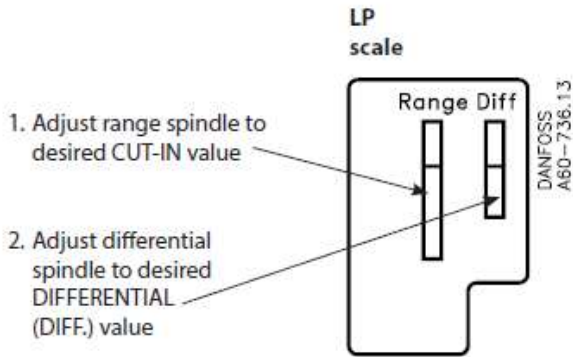

CUT-IN minus DIFFERENTIAL equals CUT-OUT

High pressure (HP) side setting

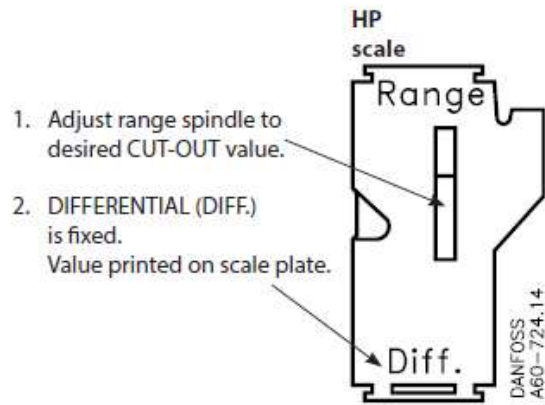

CUT-OUT minus DIFFERENTIAL equals CUT-IN

To change the pressure gauges see below how to

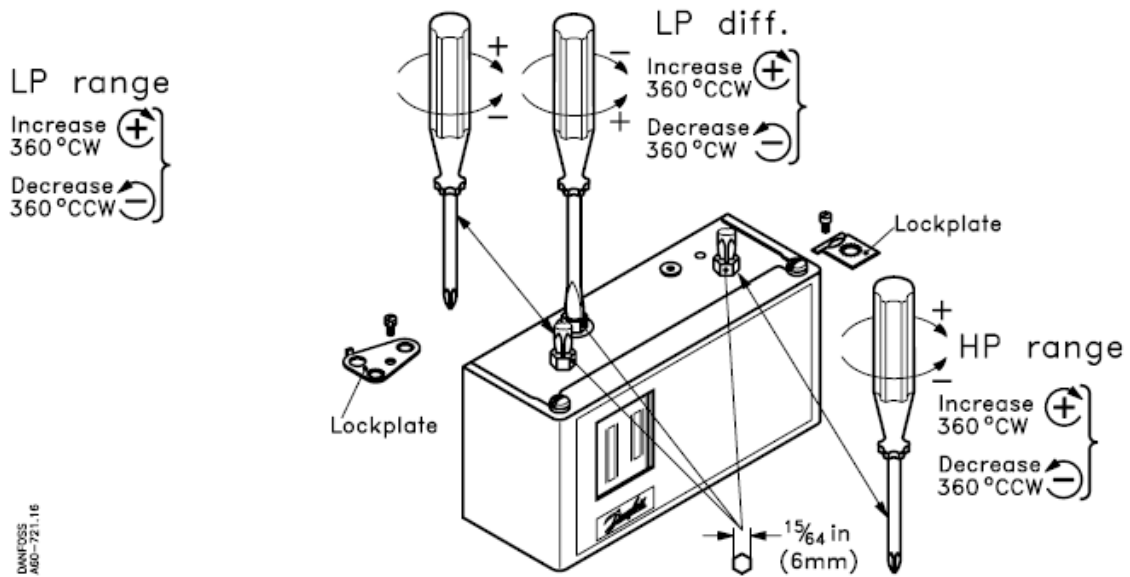

Hydraulic Commissioning

1 – Float Valve Setting

Ensure that the break tank float valve is set to its lowest position:

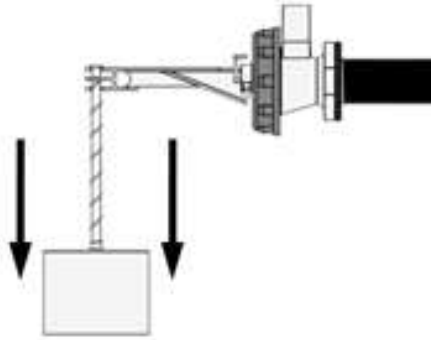

Mini Units

If a drain valve is fitted to the break tank, ensure that it is closed. Then, turn on the mains water supply and allow the break tank to fill.



When the float valve operates for the first time, it may not close immediately, causing the break tank to overfill. Once the internals of the valve have been fully wetted this should not occur again.

2 – Initial Start-up

Open the internal isolation valve within the pressurisation unit by following the steps below:

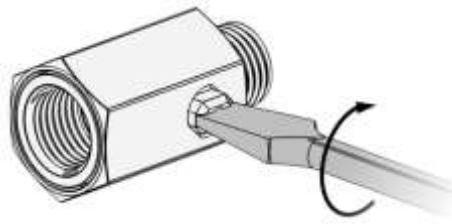

Mini Units

Once the isolation valve is open, the pressure sensor will be able to read the system pressure.

Turn on the power supply to the pressurisation unit. Depending on the current system pressure, the unit will respond in one of the following ways:



If the system pressure is below the low pressure adjust the pressure switch by turning the black screw clockwise.



If the system pressure is above the high pressure adjust the pressure switch by turning the black screw anti-clockwise.



If the system pressure is above the low pressure alarm setting, but below the cold fill setting (by an amount equal to the differential setting), the pumps will start. Once the system pressure has reached the cold fill pressure, the pump will stop.

Make sure that the cut-in and cut-out pressure is set correctly from your boiler, this can be adjusted (see the H/L pressure switch section)

Once the required system pressure has been reached, the controller will display the current system pressure. The unit is now in normal operation.

3 – Testing

To test the operation of the pressurisation unit while connected to the system, the system pressure must be lowered slowly to simulate a minor leak.

This can be achieved by using a drain point on the system, the drain point on the pressurisation unit, or by manually opening the safety relief valve.



Care must be taken not to let the pressure drop too quickly. If the system pressure falls below the low pressure set point, a low pressure fault will be displayed and the pumps will not run. The pressurisation unit is not designed to cope with a sudden loss of system pressure, which would be symptomatic of a catastrophic failure such as a burst pipe.

Once the system pressure has fallen below the cold fill setting (by an amount equal to the differential setting), the pump should start refilling the system. The pump will continue to run until the cold fill pressure has been reached.

This test demonstrates the primary function of the pressurisation unit. This test may be repeated at any time to confirm the operation of the pressurisation unit.

Maintenance

Before carrying out any maintenance please remember to first electrically isolate the equipment and then hydraulically isolate the equipment.

Please ensure that competent trained engineers are used to carry out any service or maintenance work.

It is recommended that the system as a whole is serviced and inspected annually. At that time the gas charge within the system expansion vessel (if appropriate) should be checked and verified as equal to the cold fill pressure set on this pressurisation unit.

The cold fill pressure should be equal to the static height of the system +0.3 bar, to ensure air is capable of being purged from the uppermost points of the system.

The pump, float valve (ball cock) and high / Low switches should also be checked at this interval as a minimum.

Check the internal filters within the break tank are present and clear.

A visual check of the equipment for corrosion or damage should also be carried out and noted. All settings should be recorded and compared to the previous service or commissioning for analysis of the system as a whole.

This equipment is designed to provide periodic water top up in the event of minor losses from a sealed heating or chilled system. Please consider the environment and report / rectify any significant water losses.

Maintenance Timeline

Commissioning by trained engineers	Day 1
Check alarms and counters	First 6 months
Service and Inspection	Annually thereafter



If any faults are identified during these checks, please refer to the Troubleshooting section of this manual. If replacement parts are required, please refer to the Spares section for part codes.

Wiring diagram

Mains Power Switch



Pump Selector Switch



Pump



Pump Pressure Switch

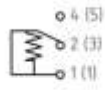

Break On Rise
1&2 (1&3)

Combined High/Low Switch

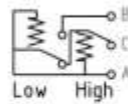

Normally Closed A&C
Normally Open A&B

Separate High/Low Arrangement

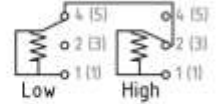

Make On Rise 1&4 (1&5)
Break On Rise 1&2 (1&3)

Live
Neutral
Earth (Ground)

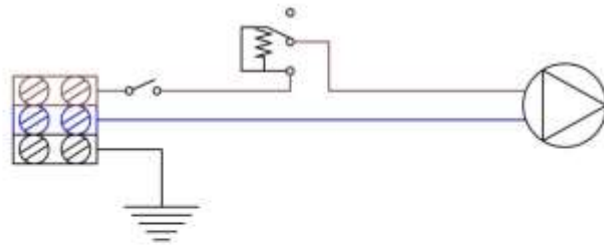

Single Pump Units

Live
Neutral
Earth (Ground)

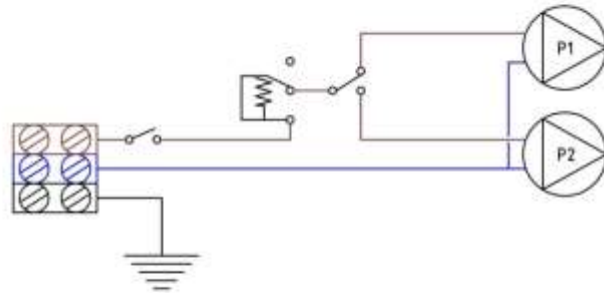

Twin Pump Units

Combined High/Low

Boiler Control IN
Boiler Control OUT

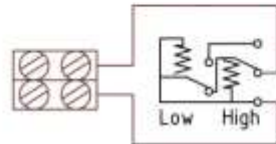

Boiler Control IN
Boiler Control OUT

Separate High/Low

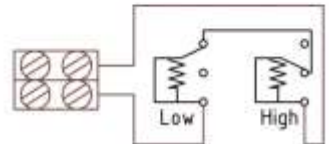

Spare Parts



The drawings on the following pages show the internal components for the pressurisation equipment. Due to continuing development and minor design changes, some components may be changed without notice. Therefore, the drawings may not accurately reflect the current production design. If in any doubt about the compatibility of replacement parts, please contact BOSS.

Mini Models (MX1-3HL, MX2-3HL)

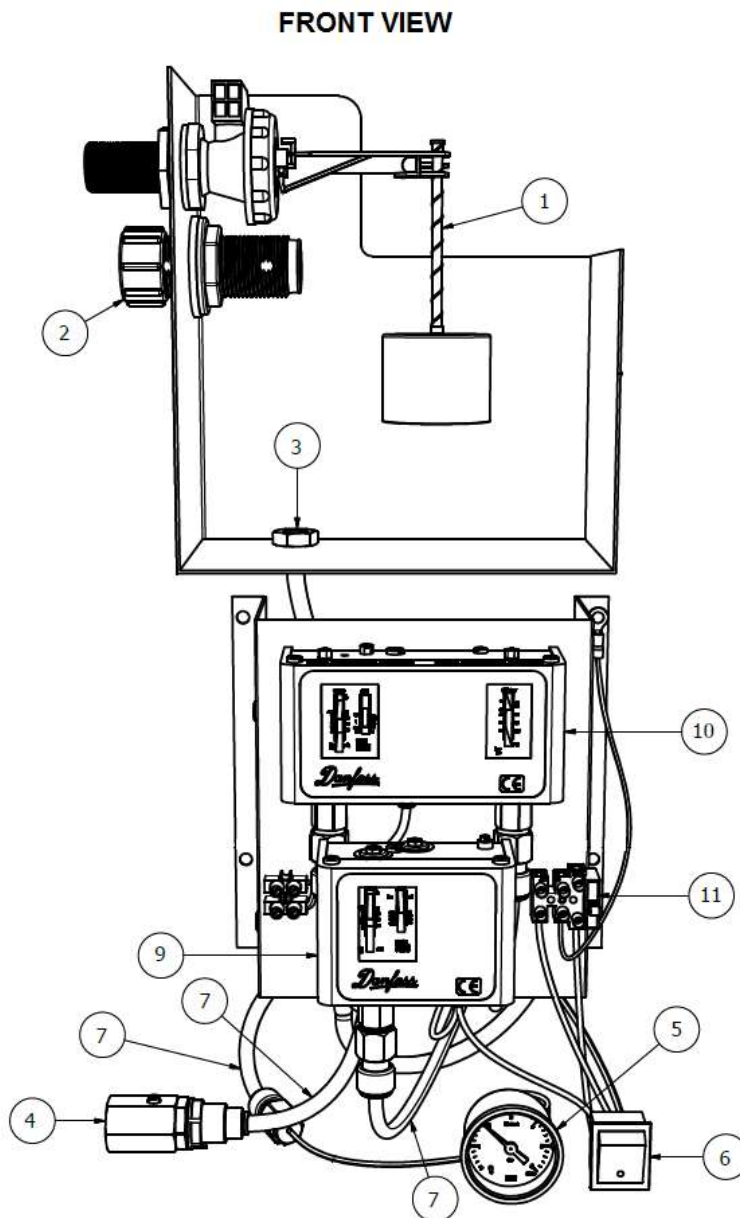

*Image for indication only

BACK VIEW

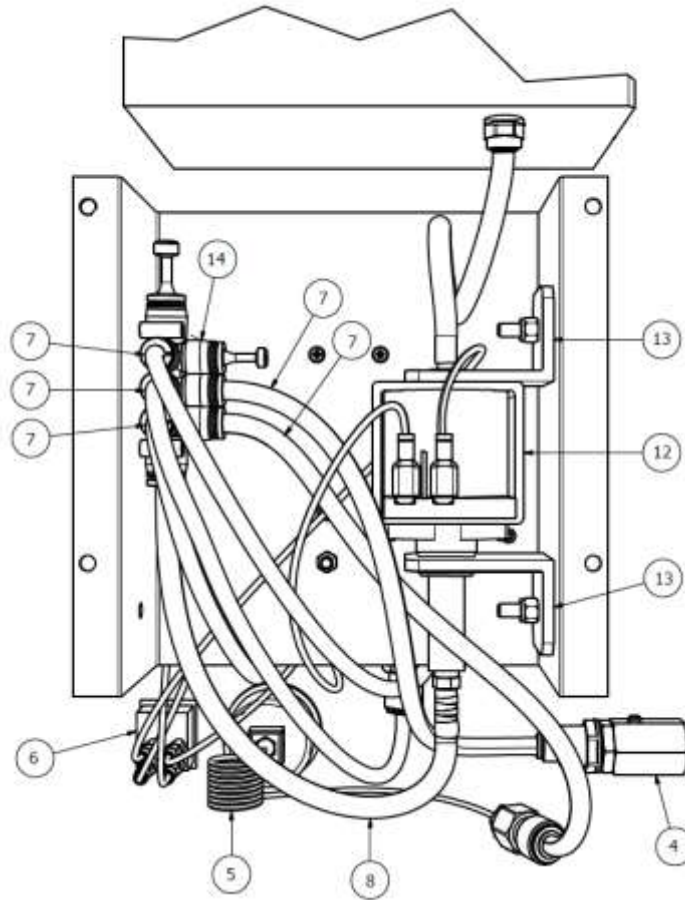

#	Description	Part Code
1	Mini Float Valve	BSS M003
2	22 mm Overflow Connection	BSS M021
3	¼" Brass Nut	BSS M006
4	¼" Ball Valve	BSS M005
5	40 mm Pressure Gauge c/w Capillary	BSS M004
6	Rocker switch	BSS F014
7	6 mm Poly-tube	BSS M014
8	8 mm Poly-tube	BSS M015
9	Pump Control Pressure Switch	FC TBV BOSS
10	High/Low Pressure Switch	FC TBV TWIN
11	Fused Terminal Block	BSS R002
12	Pump – All Models (Model E EP77)	BSS M024
13	Flexible Pump Support Bracket	BSS M022
14	6mm x 8mm Push-Fit Manifold	FC MANIFOLD 8X6

Troubleshooting

If for any reason the pressurisation unit does not seem to be functioning correctly, please refer to the table below for a list of solutions to known problems.



If the pressurisation unit is showing a fault code on the display, holding down the [SET] button will cause the current system pressure to be temporarily shown on the display.

Fault Finding

- Check electrical supply.
- Check for external controls affecting the unit.
- If the pump is running continuously:
 - Either the system is not full (possibly a leak)
 - Check the pump pressure switch operation
 - Check the Pressure Reducing Valve operation
- If the pump does not run:
 - Check the pump pressure switch operation
 - Check the pump operation
 - Check the internal filter within the break tank is present and clear
- If the unit fails to pressurise the system:
 - Check the system connection valve is open
 - The operation of the break tank float valve that there is water available in the break tank
 - Check the internal filter within the break tank is clear
 - Check for system leaks
- For intermittent running, but normal when pressurising, check for system leaks
- If the system over-pressurises:
 - Check the operation of the pump pressure switch
 - Check the operation of the Pressure Reducing Valve (if fitted)

Service Logs

This service log should be completed by the service engineer after each annual service.

Date		Range	
Engineers Name		Differential	
Company			
Contact Number			
Comments			

Date		Range	
Engineers Name		Differential	
Company			
Contact Number			
Comments			

Date		Range	
Engineers Name		Differential	
Company			
Contact Number			
Comments			

Date		Range	
Engineers Name		Differential	
Company			
Contact Number			
Comments			

Date		Range	
Engineers Name		Differential	
Company			
Contact Number			
Comments			

Date		Range	
Engineers Name		Differential	
Company			
Contact Number			
Comments			

Date		Range	
Engineers Name		Differential	
Company			
Contact Number			
Comments			

Date		Range	
Engineers Name		Differential	
Company			
Contact Number			
Comments			

Warranty Details

Warranty - What Is Covered?

The BOSS warranty on equipment supplied to distribution and OEM covers manufacturing defects, under our standard terms and conditions of sale.

If the unit is identified with a manufacturing defect then no charge is made for correcting the defect.

The BOSS equipment is manufactured to order and is clearly marked, where applicable, with a unique serial number, allowing traceability to both individual model configuration and the engineer or site responsible for the build and test.

Warranty - What Is Not Covered?

If a defect or problem has arisen as a direct result of the connected system, misuse, incorrect handling, incorrect installation or incorrect commissioning then any service visit is chargeable.

If a defect is identified as a manufacturing defect it will be addressed as described above, additional remedial works as a result of misuse, incorrect handling, incorrect installation or incorrect commissioning then the additional work is chargeable.

Installation costs and/or consequential losses are not covered by this agreement.

Conditions of warranty

DOS - Date Of Supply

DOC - Date Of Commissioning

Equipment	Conditions	Timescale
BOSS Pressurisation Equipment	That there is an appropriate safety valve on the system protecting the equipment. That the equipment is undamaged at the time of installation. That the equipment is not exposed to adverse environmental conditions. That the equipment is stored and installed in a frost free area. That the operating and maintenance instructions are followed. That the equipment is used for the purpose for which it was designed.	18 months DOS 24 months DOC

Contact Details

For further information please visit the BOSS Website at the following URL:

www.bssindustrial.co.uk

Alternatively, please contact the BSS technical team using the details below:

Phone: 0116 262 3232
Fax: 0116 253 1343
Email: enquiries@bssgroup.com

BSS Industrial

Fleet House
Lee Circle
Leicester LE1 3QQ
United Kingdom

T +44 116 256 7052

F +44 116 253 1343

E technicalteam@bssgroup.com

