



## **contecSEAL 150**

New generation metal waterstop

# 02 contecSEAL 150

## NEW GENERATION METAL WATERSTOP All the advantages of the traditional systems have been technologically combined into one single product

contecSEAL 150 is a metal waterstop made of galvanized sheet steel with a special elastic coating on both sides.

contecSEAL 150 is intended for the use as a permanent internal seal against pressurised water for construction and control joints in walls and floors and base slabs in impermeable to water concrete constructions ("White tanking") in building constructions and civil engineering without additional concrete upturn.

The product is mainly installed in the middle of the construction or control joint (base slab to wall, wall to wall, base slab to base slab, wall to floor slab) in the construction part to be waterproofed in in-situ concrete and precast construction. Suitable for horizontal and vertical applications.

Many variations of contecSEAL 150 combined with RECASTAL® Shuttering Units are possible.

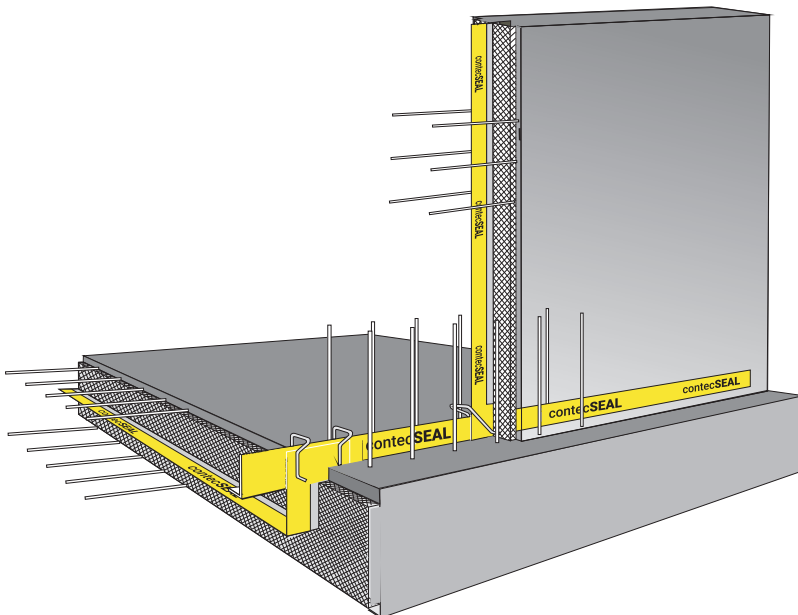

## The Benefits

- Extremely strong adhesive bond to concrete
- Increased leak path
- Fresh concrete and labyrinth seals
- Elastic, non-rigid mineral coating
- Safe application due to a special doubled sided elastic coating
- Pressure sensitive adhesive bond
- Non-stick surface
- Fast, effective installation (no protective film required, no additional concrete upstand in base slab to wall joint required)
- Embedment depth in concrete at least 3 cm
- Water pressure resistance up to 5 bar joint expansion of up to 0.5 mm and embedment depth 3 cm
- Tested for joint expansion of up to 1.0 mm at 2 bar water pressure
- Suitable for the use in changing water levels
- General building authority (abP) test certificate



# Technology

contecSEAL 150 is a metal waterstop made of galvanized sheet steel with a special elastic coating on both sides.

The special coating consists of a pressure-sensitive special adhesive which is coated with a special granulate. This creates a permanently adhesive composite system for fresh concrete with a very strong bond to concrete.

The surface-enlarging coating results in an extreme increase in the leak path and thus offers a high degree of safety.

contecSEAL 150 has been tested with up to 50 m (5 bar) hydrostatic head and, in accordance with the abP (German approval regulations), is approved for up to 20 m (2 bar) hydrostatic head in case of joint expansions of up to 0.5 mm. For joint expansions greater than 0.5 mm up to 1.0 mm, contecSEAL 150 has been tested for up to 2 bar with an embedment depth of the metal waterstop of only 3 cm. The use of contecSEAL 150 metal waterstops is also approved for control joints in in-situ and precast concrete constructions. contecSEAL 150 is also suitable and has been tested for the use in changing water levels. To achieve the highest functional reliability of the joints, the metal waterstop overlaps are preinstalled with 5 cm wide contaflexactiv active strips.

There is no need for a protective film. This ensures a high level of installation security and less installation effort.

## Increased leak path for the following surfaces

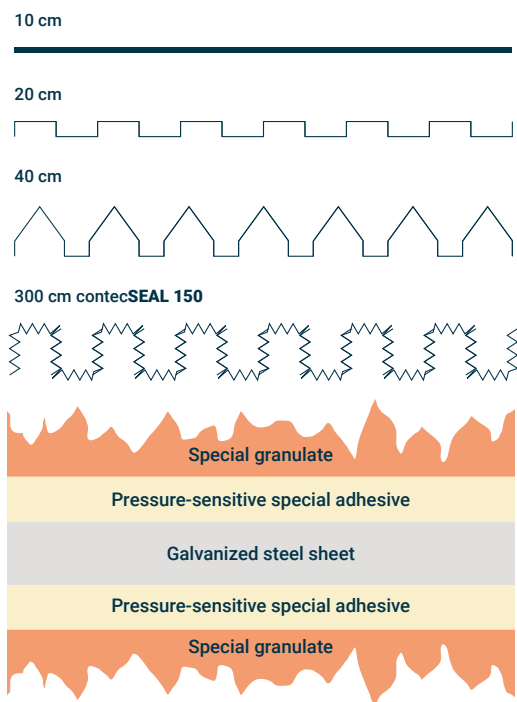

1 sq. m. of contecSEAL 150 corresponds to more than 1000 sq. m. of smooth surface

# Installation

contecSEAL 150 metal waterstops are mainly installed in the middle of the construction or control joint (base slab to wall, wall to wall, base slab to base slab, wall to floor slab) in the construction part to be waterproofed. contecSEAL 150 metal waterstop lap joints are installed with a 5 cm overlap between the individual contecSEAL 150 metal waterstops.

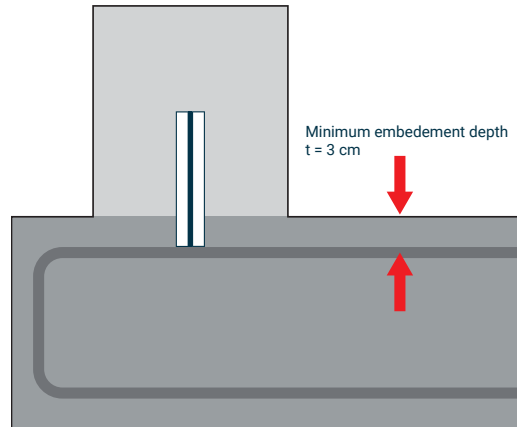

All joints between the metal waterstops are to be fixed with the separate formbraces type K23 or Fixing Clips type K23.

In base slab to wall construction joint applications, contecSEAL 150 metal waterstops are fixed to the top layer of the base slab reinforcement using the corresponding formbrace type K23 (min. 1 formbrace / m). The fixing must ensure that the installation position of the contecSEAL 150 metal waterstops does not change during concreting. The minimum embedment depth in the floor slab or in the first pour area is  $t = 3 \text{ cm}$ . The maximum embedment depth in the first pour area must not exceed half of the sheet height. Corners and diversions can be created on site by simply bending the contecSEAL 150 metal waterstops by hand. When using contecSEAL 150 metal waterstops in wall to wall or base slab to base slab construction and control joints, it is recommended to use RECOSTAL® shuttering units type AFB (to be ordered separately) in order to secure the contecSEAL 150 metal waterstops firmly in place.

contecSEAL 150 with a missing or damaged coating must not be used.





## 04 Technical data

- Basic metal waterstop: galvanized sheet steel
- Unit length: 2000 mm
- Unit height: 150 mm
- Sheet metal thickness: approx. 0.65 mm
- Total thickness: approx. 1.1 mm
- Special coating: double-sided special adhesive + granulated quartz with silicon dioxide components
- Special contact adhesive: APEO-free contact coating
- Colour: beige with white quartz inclusions
- Surface: non-adhesive

## Packaging unit

- Sturdy wooden box with 50 contecSEAL 150 metal waterstops (l = 2 m)
- 50 pc. Fixing Clips type 100/95
- 4 pc. contaflexactiv VAS 50/150 active

## Storage

Store in a dry and frost-free place in the original packaging, shelf-life max. 24 months

