

Galen's Tag Service, LLC.  
P. O. Box 516  
Prairie du Chien, WI 53821-0516  
Friday April 10, 2026

Re: WS27U0G188336

Dear Sir,

Thanks for using my services for your **1970 DODGE Coronet R/T 440 Convertible**.

**ALL**

Every CHRYSLER assembly plant has their own way of leaving **inspector stamps** into or attached to the body code plate. If your inner fender is unrestored/original paint you may notice that one of the 2 or 3 metal screws are unpainted and there is a crease near the painted screw, this is because the inspector's stamp was done into the body code plate, then an unpainted screw was installed.

**WS**

The **Coronet R/T Package** came about in 1967. The R/T was short for Road and Track, available in both a Hardtop and a Convertible.

In 1967 it was a "Package Car", meaning there were items that came standard on the car that were out of the ordinary, like the Simulated Hood Air scoop and Chrome Valve Covers on the 440. The "Package" carried over to the Charger with the standard 26" Radiator when it was ordered with the optional 440 MAGNUM engine.

The Hardtop was built at all 3 of the Assembly Plants, Lynch Road in Detroit, Los Angeles and St. Louis, the Hemi was only built at the Lynch Road & St. Louis plants. The R/T Convertible was only built at the St. Louis plant. All Coronet R/T Hardtop's shipped to CANADA and Export ordered were built at the Lynch Road plant. The body side paint stripes were standard, and were available in multiple colors.

In 1968 the Coronet R/T body went from box style to Coke bottle design, and received standard paint stripes on the upper body. A Bumblebee tape stripe was available at no extra charge.

In 1969 the R/T came standard with a Bumblebee tape stripe in Black, Red or White, the stripe could also be deleted and you would receive an R/T nameplate where it would have been if it had the stripe.

In 1970, the R/T came standard with a simulated Quarter mounted air scoop with the R/T designation on the side of the scoop and a Bumblebee tape stripe.

In 1971, the R/T received a facelift, not everyone was happy with its new look. It was the last year for the R/T as a model.

From 1972-74 the Rallye Package was available with the 340, 360, 400 & 440 engine. The most recognized item on the 1972-74 Rallye Package was the Power Bulge hood with the CID callout.

# 1970 DODGE Coronet R/T Convertible

**B** Broadcast Copy: Station #-St. Louis  
**060204** Sequence Number: Broadcast Print  
**210** Tuesday - February 10, 1970  
 Scheduled Production Date  
**222116** Vehicle Order Number  
**WS** Car Line: DODGE Coronet R/T  
**27** Body Type: Convertible  
**U** Engine: 440 CID 1-4BBL 375hp **V8** DUAL EXHAUST  
**0** Model Year: 1970 F-SERIES  
**G** Assembly Plant: St. Louis, MO  
**183336** Assembly Plant Sequential Number  
**Y05** Build to Spec's for: U.S.A.  
**Y16** Order Type: Sales Bank  
**E86** Engine: 440 CID 1-4BBL 375hp **V8** MAGNUM  
**D32** Transmission: A727 Torqueflite  
**D53** Axle Ratio: 3.23 w/8.75" DIA.  
**NO** Axle: Sure-Grip  
**T86** Tires: F70 x 14" WSW POLYGLAS 2-4 PLY  
**D** Trim Grade: Deluxe STD WS  
**6** Front Seat: Vinyl Bucket  
**X9** Interior: Black  
**TX9** Upper Door Frame Color: Black  
**V01** Paint Style: Mono-Tone  
**EK2** Body Paint: Go Mango HI IMPACT  
**V3X** Roof/Color: Convertible/Black  
**355** B-Body - A.T. - Floor Shift  
**X9** Steering Column: Black  
**7000** Steering: Power - N88: No L65: No  
**08 X9** Steering Wheel Type/Color: 3-Spoke/Black  
**43 X9** Type/Color: Partial Horn Ring/Black  
**2998960** Radiator Width: 22" STD COOL AT  
**3462114** Radiator Inlet Hose: 22" 383/440  
**3438172** Alternator: 37 Amp MONO PULLEY H11  
**2863224** Fan: 7-Blade/18.0" Dia.  
**1851959** Fan Spacer: 1.06" Length  
**2642969** Battery-Amp/Series/Caps: 70/27/Red  
**V8X** Stripes: Black Bumblebee Sport TAPE  
**1859127** Vac. Fitting: Intake "Plug"  
**115** Engine Assy.: 440 4BBL w/A.T. & Heater  
**3438554** Carb.: Carter AVS 4BBL #4738 U-AUTO-ALL  
**3410670** Trans.: A727 Torqueflite/440 4BBL HP  
**2538932** Speedo. Pinion: 32 Teeth/Black (T86+D53)  
**2996162** Prop/Shaft: #7290/3.25" x 52.07"  
**3432054** Axle Assy: 3.23:1 S/A 8.75"-11" Drums  
**17** Road Wheels: 14 x 6.0" Stamped  
**TX9** Color: Black Painted Wheels (5)  
**17** Spare: 14 x 6.0" Stamped Steel  
**2944435** Wheel Cover: Deluxe DODGE DIVISION W11  
**3466479** K-Frame: B Body 440 with Skid  
**2835862** Ft. Sway Bar: .88" Diameter  
**3400556** Ft. Shocks: Firm Ride EARLY  
**3400592** Rr. Shocks: Firm Ride  
**23** Front Brake: H.D. Drum-11"  
**1857781** LT Torsion Bar: .92 x 41" HEMI  
**1857780** RT Torsion Bar: .92 x 41" HEMI  
**2539794** LT Rear Spring: 6 Leaf HEMI  
**2539964** RT Rear Spring: 5½½ Leaf HEMI  
**57 01** Clutch Brake Pedal: M/B-A.T.-With J41  
**3462552** Idle Label: 800RPM in Neut. 2½  
**3402068** Tire Label: F70 x 14" Load Range B 30 30 26 26  
**00** Lt. Exhaust: [Engine H-Pipe]  
**3404802** Rt. Exhaust: W-440 Engine H-Pipe  
**3404003** Lt. Tailpipe: Less Chrome Tip  
**3404810** Rt. Tailpipe: Less Chrome Tip  
**BP 5** Car Height: B Body-POWER STEERING-6"  
**51** Master Cylinder: B-Body/Drum  
**11** 11:00AM Broadcast Print Hour  
**69** #69 Broadcast Print Seq./Hour

**NO** Light Package  
**A04** Basic Group  
**NO** Performance Axle Package  
**NO** Front Bumper Guard Package  
**NO** Rallye Instrument Cluster STD WS  
**B11** Front Brakes: HD Drum STD WS  
**NO** Brakes: Power  
**C16** Woodgrain Console  
**C23** Rear Armrests  
**C55** Front Seat: Buckets  
**NO** LH 6-Way Adjustable Seat  
**C93** Carpets  
**STD** Alternator: 37 Amp  
**F25** Battery: HD 70 Amp/Red Caps  
**NO** Gauge: Oil Pressure  
**G15** Glass: Tinted Windshield only  
**G33** Mirror: Outside LH Remote Chrome  
**NO** Mirror: Outside RH Manual Chrome  
**G41** Mirror: Inside Day/Nite R/View  
**H11** Heater: With Defroster  
**NO** Defogger: Rear Window  
**J11** Glove Box Lock  
**J15** Cigar Lighter  
**NO** Electric Clock  
**J25** Wipers: 3-Speed w/Electric Washers  
**J31** Horns: Dual  
**J41** Pedals Dress Up STD WP-S  
**NO** Hood Pins  
**J55** Undercoating WITH HOOD INSULATION PAD  
**L05** Lite: Map/Courtesy STD WS+A01  
**L11** Lite: Glove Box STD WS+A01  
**L15** Lite: Ash Receiver STD WS+A01  
**NO** Lite: Cargo/Trunk  
**NO** Fender Mounted Turn Indicators  
**NO** Headlamp Time Delay w/Timer  
**NO** Lamp: Ign. Switch w/Time Delay  
**NO** Headlamp-On Signal  
**L76** Lamp: Heater Controls  
**NO** Moldings: Door Edge WS  
**NO** Moldings: Body Sill  
**M26** Moldings: Wheel Lip STD  
**M31** Moldings: Body Belt  
**M42** Moldings: Front End  
**M46** Wheelhouse Air Scoop STD WS  
**M81** Bumper Guards-Front  
**N41** Dual Exhaust System  
**NO** Chrome Exhaust Tips  
**NO** Torque Drive Fan  
**NO** Maximum Cooling Pkg-Less fan  
**NO** Tachometer w/Clock  
**NO** Auto Speed Control  
**NO** Carb Fresh Air Pkg  
**NO** Noise Reduction Package  
**P37** Power Convertible Top WP-S27  
**R11** Radio: AM Antenna/Telescopic  
**NO** Rear Speaker  
**S15** Ft. Suspension: HEMI  
**S25** Shock Absorbers: Firm Ride-Ft/Rr  
**S31** Front Sway Bar  
**S79** Horn Ring: Lower ½  
**S77** Power Steering  
**NO** Steering Wheel: Woodgrain  
**W11** Wheel Covers: Deluxe  
**STD** Road Wheels: Stamped

REMARKS: None

**Note: This vehicle has not been inspected in person by Galen's Tag Service, LLC.**

**The above information is to the best of my knowledge at the time of printing.**

Decoded for:



Decoded by:

Galen's Tag Service, LLC.  
 P.O. Box 516  
 Prairie du Chien, WI 53821-0516

## 1970 DODGE Coronet R/T Convertible



THE BODY CODE PLATE IS READ FROM LEFT TO RIGHT AND FROM BOTTOM TO TOP

E86	ENGINE: 440 CID 1-4BBL 375hp <b>V8</b> DUAL EXHAUST		
D32	TRANSMISSION: A727 Torqueflite Automatic		
WS	CAR LINE: DODGE Coronet R/T	<u>US SHIPMENTS</u>	<u>SHPG WT</u>
27	Body Type: Convertible ST. LOUIS PLANT ONLY	236	3610#
U	ENGINE: 440 CID 1-4BBL 375hp <b>V8</b> DUAL EXHAUST		
0	MODEL YEAR: 1970 F-SERIES		
G	ASSEMBLY PLANT: St. Louis, MO		
<u>188336</u>	<u>ASSEMBLY PLANT SEQUENCE NUMBER</u>		
EK2	BODY PAINT: Go Mango HI IMPACT		
D	TRIM GRADE: Deluxe		
6	FRONT SEATS: Vinyl Buckets		
X9	INTERIOR: Black		
TX9	UPPER DOOR FRAME COLOR: Black		
210	SCHEDULED PRODUCTION DATE: Tuesday - February 10, 1970		
<u>222116</u>	<u>VEHICLE ORDER NUMBER Y16-SALES BANK</u>		
V3X	ROOF/COLOR: Convertible/Black		
A04	Basic Group		
C16	Woodgrain Console FLOOR SHIFTER		
C55	Bucket Seats		
G33	Outside LH Remote Mirror-Chrome Conventional		
J25	3-Speed Wipers w/Electric Washers		
M31	Body Belt Moldings		
R11	Radio: Music Master AM		
V8X	STRIPE/COLOR: Transverse Sport/ Black Tape		
Y16	Sales Bank		
END	The end of Body Plate Codes		

41L Inspector's Stamp TYPICAL OF ST. LOUIS PLANT

Decoded for:

Decoded by:

Galen's Tag Service, LLC.  
 P.O. Box 516  
 Prairie du Chien, WI 53821-0516

**Note: This vehicle has not been inspected in person by Galen's Tag Service, LLC.  
 The above information is to the best of my knowledge at the time of printing.**

# 1970 DODGE Coronet R/T Convertible

+	+
M31 R11 V8X Y16 END	
V3X A04 C16 C55 G33 J25	
EK2 D6X9 TX9 210 222116	
E86 D32 WS27 U0G 188336	

THE BODY CODE PLATE IS READ FROM LEFT TO RIGHT AND FROM BOTTOM TO TOP

E86	ENGINE: 440 CID 1-4BBL 375hp V8 DUAL EXHAUST		
D32	TRANSMISSION: A727 Torqueflite Automatic		
WS	CAR LINE: DODGE Coronet R/T	US SHIPMENTS	SHPG WT
27	Body Type: Convertible ST. LOUIS PLANT ONLY	236	3610#
U	ENGINE: 440 CID 1-4BBL 375hp V8 DUAL EXHAUST		
0	MODEL YEAR: 1970 F-SERIES		
G	ASSEMBLY PLANT: St. Louis, MO		
188336	ASSEMBLY PLANT SEQUENCE NUMBER		
EK2	BODY PAINT: Go Mango HI IMPACT		
D	TRIM GRADE: Deluxe		
6	FRONT SEATS: Vinyl Buckets		
X9	INTERIOR: Black		
TX9	UPPER DOOR FRAME COLOR: Black		
210	SCHEDULED PRODUCTION DATE: Tuesday - February 10, 1970		
222116	VEHICLE ORDER NUMBER Y16-SALES BANK		
V3X	ROOF/COLOR: Convertible/Black		
A04	Basic Group		
C16	Woodgrain Console FLOOR SHIFTER		
C55	Bucket Seats		
G33	Outside LH Remote Mirror-Chrome Conventional		
J25	3-Speed Wipers w/Electric Washers		
M31	Body Belt Moldings		
R11	Radio: Music Master AM		
V8X	STRIPE/COLOR: Transverse Sport/ Black Tape		
Y16	Sales Bank		
END	The end of Body Plate Codes		
41L	Inspector's Stamp TYPICAL OF ST. LOUIS PLANT		

Decoded for:



Decoded by:

Galen's Tag Service, LLC.  
P.O. Box 516  
Prairie du Chien, WI 53821-0516

**Note: This vehicle has not been inspected in person by Galen's Tag Service, LLC.**

**The above information is to the best of my knowledge at the time of printing.**



Body Code Plate “Decoded” by Galen’s Tag Service, LLC.



Public Vehicle Identification Number

**WS27U0G188336**



Decoded for:

**DISCLAIMER: This vehicle has not been inspected in person by Galen’s Tag Service. This decoding by Galen’s Tag Service, LLC was conducted by mail. This decoding in no way verifies the accuracy or correctness of the Vehicle, Body, Engine or Transmission. The above information is to the best of my knowledge at time of printing.**

Galen’s Tag Service, LLC.

Galen V. Govier, Managing Member

04-10-2026

Date of Decoding

**No. 2627029**

G.T.S., LLC.  
P. O. Box 516  
Prairie du Chien, WI 53821-0516  
(608) 326-6346 Office  
**Invoice 2627029**

# Galen's Registry

04/10/2026

This 1970 440 4BBL DODGE Coronet R/T Convertible VIN **WS27U0G188336** is now in the Registry.

There were 219 - 1970 440 4BBL DODGE Coronet R/T Convertible's built to Spec's for U.S.A. 16-4 Speeds and 203-Autos. CANADIAN & EXPORT shipments are unknown.

## VEHICLES CURRENTLY REGISTERED IN GALEN'S REGISTRY

As of the above date, it is # **49 of 68** in VIN sequence of all 1970 440 4BBL DODGE Coronet R/T Convertible's accounted for at the St. Louis, MO plant and built to spec's for: **the U.S.A.**

1970 440 4BBL DODGE Coronet R/T Convertibles were only built at the St. Louis, MO assembly plant.

**Note: This vehicle has not been inspected in person by Galen's Tag Service, LLC.**

**The above information is to the best of my knowledge at the time of printing.**

If there is anything else I can do for you, do not hesitate to write.

Galen's Tag Service, LLC.

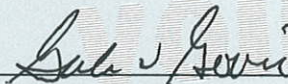

Galen V. Govier  
Managing Member

Registered  
068-WS27U0G-USA  
009-WS27U0G-CANADA  
000-WS27U0G-EXPORT

GVG/gg

*Keep the Faith*

# Galen's Registry

Page 2

04/10/2026

In reference to your inquiry, I have completed the following additional research for **WS27U0G188336**.

These are only numbers of vehicles that are accounted for, these are not complete amounts. The amounts below include all **U.S.A., CANADIAN & EXPORT** ordered **WS27U0's** accounted for to date.

	Plant "G"			
To date: yours is	# 56	of	77 - WS27U0's	registered in VIN sequence.
and yours is	# 39	of	53 - WS27U0's"	w/D32-Transmission.
and yours is	# 32	of	47 - WS27U0's"	w/C16-Console.
and yours is	# 27	of	37 - WS27U0's"	w/V3X-Black Convertible Top.
and yours is	# 24	of	37 - WS27U0's"	w/R11-Radio.
and yours is	# 26	of	33 - WS27U0's"	w/o A62-Rallye Instruments.
and yours is	# 20	of	28 - WS27U0's"	w/D6X9-Trim.
and yours is	# 13	of	17 - WS27U0's"	w/V8X-Black Bumblebee Stripe.
and yours is	# 2	of	2 - WS27U0's "	w/EK2-Body Paint.
and yours is	# 1	of	1 - WS27U0's "	w/Above Combination.

**Note: This vehicle has not been inspected in person by Galen's Tag Service, LLC.**

**The above information is to the best of my knowledge at the time of printing.**

If there is anything else I can do for you, do not hesitate to write.

Galen's Tag Service, LLC.

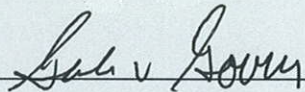

Galen V. Govier  
Managing Member

GVG/gg

# Galen's Registry

03/31/2026

In reference to your inquiry, I have completed the following additional research for **WS27U0G188336**.

The amounts below include all **U.S.A.** ordered **1970 DODGE Coronet R/T 2 Door Hardtop's** built. Detailed production numbers are not available for **CANADIAN** or **Export** ordered vehicles.

There were	236 - <b>WS27*0</b>	Shipments to the U.S.A.	
<b>THE ABOVE NUMBERS ARE ACCURATE; THE NUMBERS BELOW ARE A PERCENTAGE OF THE U.S.A. SHIPMENTS.</b>			
And there were	219 - <b>WS27*0's</b>	"	w/ <b>E86</b> -Engine 440 4V.
And there were	203 - <b>WS27*0's</b>	"	w/ <b>D34</b> + <b>E86</b> -Transmission.
And there were	200 - <b>WS27*0's</b>	"	w/ <b>C16</b> -Console.
And there were	176 - <b>WS27*0's</b>	"	w/ <b>V80</b> -Tape Stripe-Bee.
And there were	146 - <b>WS27*0's</b>	"	w/ <b>S79</b> -Steering Wheel-Partial H/Ring.
And there were	132 - <b>WS27*0's</b>	"	w/ <b>STD</b> Instruments.
And there were	128 - <b>WS27*0's</b>	"	w/ <b>V3X</b> -Convertible Top-Black.
And there were	112 - <b>WS27*0's</b>	"	w/ <b>D6X9</b> -Vinyl Buckets-Black
And there were	100 - <b>WS27*0's</b>	"	w/ <b>T86</b> -Tires: F70x14" WSW.
And there were	82 - <b>WS27*0's</b>	"	w/ <b>G15</b> -Solex-Windshield.
And there were	64 - <b>WS27*0's</b>	"	w/ <b>A04</b> -Basic Radio Group.
And there were	8 - <b>WS27*0's</b>	"	w/ <b>EK2</b> -Go Mango *                      3 exist
And there were	4 - <b>WS27*0's</b>	"	w/ <b>D34</b> + <b>D53</b> + <b>E86</b> -Combo.
COMBINATIONS LIKE PAINT AND TRIM AND/OR ENGINE AND PAINT CANNOT BE DETERMINED!			

If there is anything else I can do for you, do not hesitate to write.

Galen's Tag Service, LLC.

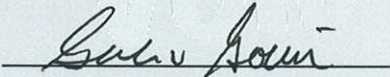

Galen V. Govier  
Managing Member

GVG/gg

**F Series 1970 Basic Car Prices & Standard Equipment**

**WS27 DODGE CORONET R/T -8- CONVERTIBLE** 1970 \$ 3,643.00

THE FOLLOWING ITEMS OF EQUIPMENT  
ARE STANDARD ON THIS MODEL-REAR ARM  
RESTS, VINYL TRIM, DUAL HORNS,  
FRONT AIR FOAM SEAT, CUSHION, BUCKET  
SEATS, MAGNUM 440 CID 4 BBL. ENGINE,  
TORQUEFLITE TRANSMISSION, WIDE OVAL  
RWL TIRES, H.D. DRUM BRAKES, H.D.  
SUSPENSION, 3 SPEED WINDSHIELD  
WIPERS, BUMBLEBEE STRIPE.  
SIMULATED QUARTER SCOOPS.

\* S15.  
FUEL INLET: Behind rear license plate.  
FUEL TANK CAPACITY: 19 Gallons  
OVERALL LENGTH: 209.2"  
OVERALL WIDTH: 76.7"  
OVERALL HEIGHT: 53.0"  
**SHIPPING WEIGHT: 3610#**  
TRACK-FT: 59.7"  
TRACK-RR: 59.2"  
TURNING DIAMETER (curb-to-curb): 40.9'  
WHEELBASE: 117.0"

**F Series 1970 Accessories, Drivetrain & Options**

**A04** CORONET BASIC GROUP 1970 WS2\*U  
**G33** Outside LH Remote Chrome Mirror,  
**J25** 3-Speed Wipers w/Electric Washers-Std 383 4bbl,  
**R11** Music Master AM Radio,  
**S77** Power Steering,  
**W11** Deluxe Wheel Covers.  
Optional on Coronet R/T.

**STD** CORONET R/T INSTRUMENT PANEL 1970 WS2\*U  
**J21** Clock OPTIONAL-N/A with N85  
**N85** Tachometer OPTIONAL-N/A with J21  
Oil Pressure Light  
Rocker type Switch for headlights  
Thumbwheel dimmer for instrument panel lights  
Windshield washer button  
Rocker type switch for windshield wipers  
Woodgrain Instrument Appliqué  
Standard on Coronet R/T

**Note: This vehicle has not been inspected in person by Galen's Tag Service, LLC.**

**The above information is to the best of my knowledge at the time of printing.**

WS27U0G188336

<b>B11</b>	<b>HD DRUM BRAKES</b>	<b>1970 WS2*U</b>		
	11x3.0"-Drum Brakes-Front,			
	11x2.5"-Drum Brakes-Rear,			
	Eff. lining area: 234.1 sq. in.			
	Total swept area: 380.1 sq. in.			
	Coiled spring around drum perimeter (Anti-squeak)			
	Standard on Coronet R/T.			
<b>D32</b>	<b>TORQUEFLITE AUTOMATIC TRANSMISSION</b>	<b>1970 WS2*U</b>		
<b>D53</b>	3.23:1 Gear Ratio 8.75" STD Axle (Std w/4bbl),			
<b>D91</b>	Sure-Grip Differential OPTIONAL			
<b>D56</b>	3.55:1 Gear Ratio 8.75" S/G Axle (Opt w/4bbl),		A36 PKG	
<b>D58</b>	4.10:1 Gear Ratio 9.75" S/G Axle (Opt w/4bbl),		A32 PKG	
<b>D91</b>	Sure-Grip Differential STANDARD WITH OPTIONAL GEAR RATIO			
	440 1-4bbl A727-B - Stall Speed = 2000-2300rpm u			3410670
	Steering Wheel Anti-Theft Lock/Park,			
<b>STD</b>	Column Shift less Console			
<b>C16</b>	Woodgrain Shift Knob with Console.			
	Standard on Coronet R/T.			
<b>E86</b>	<b>440 CID 1-4BBL MAGNUM V8 ENGINE:</b>	<b>1970 WS2*U</b>		
<b>STD</b>	Engine Package: A134.			440
<b>STD</b>	Engine Type: Overhead Valve V8,			All V8
<b>STD</b>	Piston Displacement: 440 cu. In.			440
<b>STD</b>	Air Cleaner: Unsilenced, Dual Snorkel,			
<b>STD</b>	Alternator w/HTR: 37 Amp MONO GROOVE PULLEY		3438172	All V8 exc
<b>F25</b>	Battery: 70 Amp/Hr-Series 27 - Red Caps,		2642969	426/440
<b>STD</b>	Bore & Stroke: 4.32" x 3.75",			440
<b>STD</b>	Camshaft: High-lift, High performance,			E86
<b>STD</b>	Carburetor w/A.T.: Carter AVS 4BBL #4738S		3418554	E86
<b>STD</b>	Compression Ratio: 9.7:1,			E86
<b>STD</b>	Distributor: Single Point,		3438222	E86
<b>STD</b>	Engine color: HEMI ORANGE,			E86
<b>STD</b>	Engine ID: F440 HP or HP2,			E86
<b>STD</b>	Engine ID location: Top front of block,		RB	E80
<b>N41</b>	Exhaust: Dual System-Low Restriction Mufflers,		E80	
<b>STD</b>	Firing Order: 1-8-4-3-6-5-7-2,			All V8
<b>STD</b>	Fuel Recommended: Premium-Leaded,			E80
<b>STD</b>	Horsepower/RPM: 375@4600,			E86
<b>STD</b>	Lifters/Tappets: Hydraulic,			All V8 exc:
<b>STD</b>	Oil Capacity: 6 Quarts plus Filter,			440HP
<b>STD</b>	Radiator w/A.T.: 22" Width.	B/E-Body	2998960	440
	-Fan Shroud One piece/Plastic		2998326	426
<b>STD</b>	Radiator cap: 16 psi pressure-vent w/safety cap stops,	ALL		
<b>STD</b>	Solenoid Throttle Stop,		DR1114429	All HP
<b>STD</b>	Spark Plugs: Champion J11-Y,			E86
<b>STD</b>	Starter: Reduction gear, high torque,		2875553	ALL
<b>STD</b>	Thermostat: 195 degree on 8-Cylinder,			All V8
<b>STD</b>	Torque/Ft Lbs: 480@3200,			E86
<b>STD</b>	Voltage Regulator: 12 Volt, moisture-protected,	3438150	All	
	Standard on Coronet R/T.			

**Note: This vehicle has not been inspected in person by Galen's Tag Service, LLC.**

**The above information is to the best of my knowledge at the time of printing.**

<b>R11</b>	<p>AM RADIO WITH FRONT SPEAKER 2 WATT Textured Black KNOBS on left of dial, BUTTONS: 5-Chrome, WORDING: Chrysler Solid State. Includes 1 front 4X10" oval speaker w/2.55-oz. magnet. Telescopic antenna installed on right front fender. Optional on Coronet R/T.</p>	1970 WS2*U
<b>S15</b>	<p>HEMI SUSPENSION W/SWAY BAR Front Sway Bar, -.94" Diameter, Firm Ride Shock Absorbers, -FT ALL YEAR @ ST. LOUIS -RR HEMI Torsion Bars, -RH PAINT MARKINGS: BROWN (1) -LH PAINT MARKINGS: BROWN (2) -.92" Diameter, -41" Length, H.D. Rear Springs. -5½½ Leaf-RH SIDE (½½ to Ft) -6 Leaf-LH SIDE Standard on all Axle Packages. Includes Torque boxes on: -1970 Coronet R/T Convertible. Optional on Coronet R/T.</p>	<p>1970 WS2*U  3835862  3400556 3400592  1857780 1857781    2539964 2539794</p>
<b>V8- V8X</b>	<p>STRIPE/COLOR: TRANSVERSE SPORT TAPE Black Bumblebee Stripe Not available with any other Stripe or Body Side Moulding. Standard on Coronet R/T.</p>	1970 WS2*U
<b>Y16</b>	<p>SALES BANK ORDER The Sales Bank is to maintain production of vehicles during the model year. They are ordered by Chrysler to maintain constant production at the assembly plants and to fill dealer quotas. Sales Bank cars are built throughout the model year.</p>	1970 WS2*U

**Note: This vehicle has not been inspected in person by Galen's Tag Service, LLC.**

**The above information is to the best of my knowledge at the time of printing.**

WS27U0G188336

<b>STD</b>	<b>TIRES</b>	<b>1970 WS2*U</b>	
T87	F 70 X 14" RWL Good-Year Polyglas		Coronet R/T
T86	F 70 X 14" WSW Good-Year Polyglas		OPTIONAL
U84	F 60 X 15" RWL Good-Year Polyglas		OPTIONAL
<b>STD</b>	<b>"ROAD WHEELS"</b>	<b>1970 WS2*U</b>	
	14 x 6.0" Stamped Steel		
	-Painted Body Color w/Hubcaps		Coronet R/T
W11	-Painted Black w/Deluxe Wheel Covers		A04
W13	-Painted Black w/Deep Dish Covers		OPTIONAL
W15	-Painted Black w/Wire Wheel Covers		OPTIONAL
W21	14 x 5.5" Rallye Wheels-With Trim Rings		OPTIONAL
W23	14 x 5.5" Road Wheels-With Trim Rings		OPTIONAL
	15 x 7.0" Stamped Steel		
	-Painted Body Color w/Hubcaps		OPTIONAL
W21	15 x 7.0" Rallye Wheels-With Trim Rings		OPTIONAL
<b>STD</b>	<b>SPARE TIRE/WHEEL</b>	<b>1970 WS2*U</b>	
	Spare Tire identical to 4 on "Road",		STANDARD
	Spare Wheel identical dimensions as 4 on "Road",		STANDARD
	14 x 5.5" - Stamped Steel Spare Wheel w/W21 & W23,		STANDARD
	14 x 6.0" - Stamped Steel Spare Wheel,		STANDARD
	15 x 7.0" - Stamped Steel Spare Wheel,		OPTIONAL
	Spare Wheel Painted Black,		

**Note: This vehicle has not been inspected in person by Galen's Tag Service, LLC.**

**The above information is to the best of my knowledge at the time of printing.**

WS27U0G188336

1970 DODGE  
YEAR MAKE

CORONET R/T  
MODEL

CONVERTIBLE  
BODY STYLE

440-4BBL  
ENGINE

AUTO  
TRANS.

[These are 95% Examples/File photos]

**EXTERIOR**



SCAT PACK-WINDOW BEES.



DEALER IDENTIFICATION.  
Frame, Nameplate or Decal.

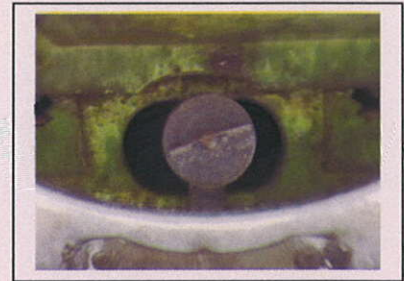

FUEL CAP.  
Location: Behind license plate.

[Examples/File Photos]

**INTERIOR**



TIRE PLACARD.  
(# 3402068)



CAUTION-CONVERTIBLE TOP.  
(#2879900)

[Examples/File Photos]



STRG COLUMN LOCK INST.  
(#2947898)

**ENGINE**



DO NOT WASH OR OIL.  
(#2863349)



C.I.D. IDENTIFICATION.  
(ORANGE BACKGROUND)

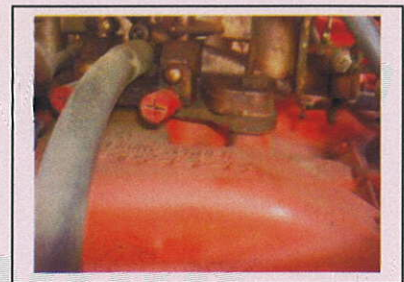

RED AIR FUEL LIMITER CAPS.  
(TYPICALLY MISSING)

[Examples/File Photos]

**Note: This vehicle has not been inspected in person by Galen's Tag Service, LLC.**

**The above information is to the best of my knowledge at the time of printing.**

**COMPARTMENT**



IDLE LABEL.  
(3462552-E86+D32=EARLY)



CHRYSLER ANTI-FREEZE DECAL.



SERIES 27/70 AMP/RED CAP.  
(#2642969)

[Examples/File Photos]

**TRUNK**



JACKING INSTRUCTIONS.  
(# 2931182)



JACK BASE DECAL.  
PLANT G=TUBE JACK



BODY HARNESS DECAL.  
(# 2983349=FW27)  
(CONVERTIBLE)

[Examples/File Photos]

**CHASSIS**



NO SURE-GRIP MARKINGS.



8.75" GEAR RATIO TAG.



UNDERCOAT TAPE PATTERN.  
TYPICAL OF ST. LOUIS PLANT.

[Examples/File Photos]

USED ONLY FOR REFERENCE OF DECAL PLACEMENT ON THIS YEAR & MODEL OF VEHICLE.

**Note: This vehicle has not been inspected in person by Galen's Tag Service, LLC.**

**The above information is to the best of my knowledge at the time of printing.**

1970 DODGE CORONET WHEELS, WHEEL COVERS & STEERING WHEELS



STD HUBCAP, exc 500.  
No sales code.  
PN: 2944089.

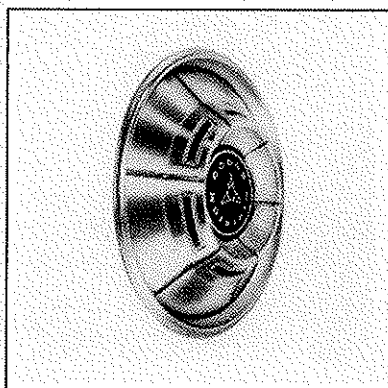

OPTIONAL WHEEL COVER.  
S/C: W11.  
PN: 2944435.

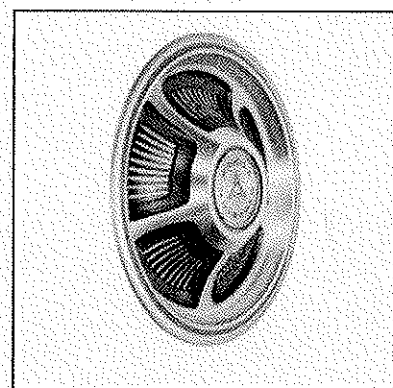

OPTIONAL WHEEL COVER.  
S/C: W13.  
PN: 2944441.

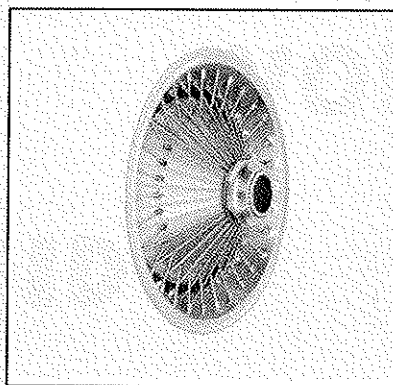

OPTIONAL WHEEL COVER.  
S/C: W15.  
PN: 2944400.

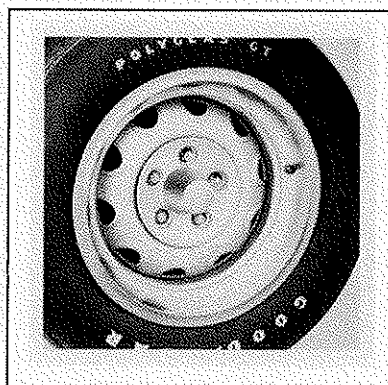

OPTIONAL WHEEL.  
S/C: W21.  
14 or 15"

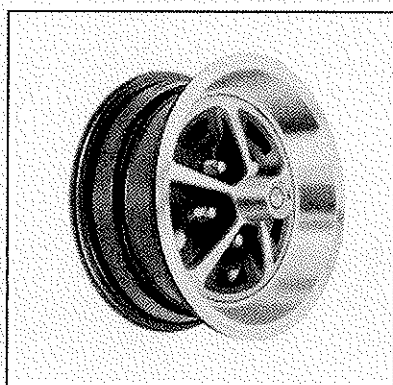

OPTIONAL WHEEL.  
S/C: W23.  
14" only.

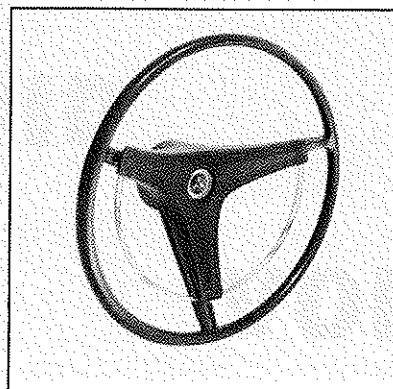

STD STEERING WHEEL, exc DLX.  
S/C: S79.  
PARTIAL HORN RING

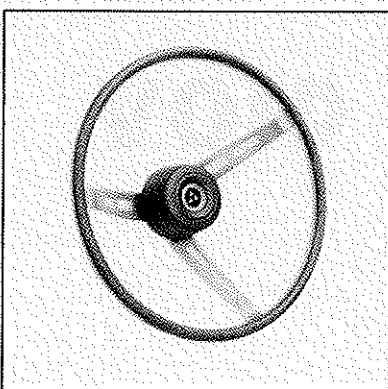

OPTIONAL STEERING WHEEL.  
S/C: S81.  
PREMIUM WOODGRAIN.

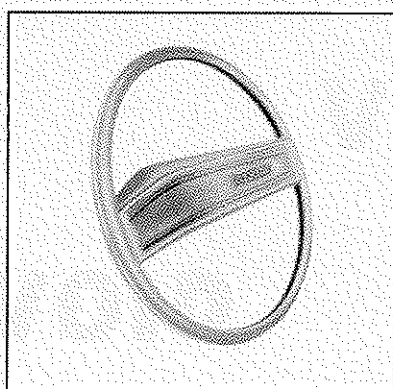

OPTIONAL STEERING WHEEL.  
S/C: S83.  
RIM BLOW.

Note: This vehicle has not been inspected in person by Galen's Tag Service, LLC.

The above information is to the best of my knowledge at the time of printing.

WS27U0G188336

**STANDARD EQUIPMENT ON A 1970 Coronet R/T Convertible**  
IF YOU WERE TO ORDER THE ABOVE VEHICLE WITHOUT A SINGLE OPTION

1<sup>st</sup> 4 digits of VIN: WS27.  
B31 Brakes, Manual 11" Drum,  
C23 Rear Armrests,  
C55 Vinyl Front Bucket Seats,  
C93 Carpeting, less-dimmer switch grommet,  
D32 Automatic Transmission w/Column Mounted Shifter,  
E86 Engine, 440 1-4BBL 375hp 440 MAGNUM,  
F25 Battery, 70 Amp, Red Cap, Series 27,  
G41 Inside Day/Night Rear View Mirror,  
H11 Front Heater w/Defroster,  
J11 Glove Box Lock,  
J15 Cigar Lighter,  
J25 Wipers, 3-Speed w/Electric Washers,  
J31 Dual Horns,  
J41 Pedals Dress Up,  
J64 Instrument Panel Woodgrain,  
L05 Lite: Map/Courtesy,  
L11 Lite: Glove Box,  
L15 Lite: Ash Receiver,  
L76 Heater controls lamp,  
M26 Wheel Lip Mouldings,  
M31 Body Belt Mouldings on Convertible,  
M46 Wheelhouse Air scoop,  
N41 Dual Exhaust w/H-Pipe,  
S15 Hemi Suspension with Front Sway Bar,  
S25 Shock Absorbers, Firm Ride,  
S79 Steering Wheel w/Partial Horn Ring,  
T86 Tires, F70-14 WSW Good-Year Polyglas (Set of 5),  
V80 Bumblebee Tape Stripes,  
W25 Wheels-Painted Body Color (Set of 4),  
22" Radiator Width,  
STD Grille with Black Paint Treatment,  
STD Rear deck applique w/Black Paint fill,  
STD Glass, All clear,  
STD Tempered Glass Backlight on Convertible,  
STD Outside LH Manual Chrome Mirror,  
STD Pentastar Insignia on Passenger lower rear front fender,  
STD Performance Hood w/CID callout & R/T nameplate,  
STD Acrylic Enamel Paint,  
STD Horizontal dash with 150MPH Speedometer,  
STD Front & Rear Seat Belts,  
STD Manual Windows,  
STD Convertible Top, Power,  
STD No Radio or Antenna,  
STD Unsilenced, Dual Snorkel Air Cleaner-Dry Element,  
STD 37 Amp Alternator w/Single groove pulley,  
STD Manual Steering,  
STD No hood insulation pad,  
STD Wheel, Spare-14x6.0"-Painted Black,  
STD Spare Tire (Full size),  
STD Front and rear wheel wells are undercoated,  
STD No Exhaust Tips,  
STD Lugnuts, LH thread on driver's side only,  
STD Hubcaps,

**NEW FOR 1970** - Column mounted Ignition Switch.

**Note: This vehicle has not been inspected in person by Galen's Tag Service, LLC.**

**The above information is to the best of my knowledge at the time of printing.**

Enclosed are the detailed registries I have compiled for your vehicle. Galen's Registry shows how many cars like yours are accounted for at the same plant that built your car. Page 2 shows the major options and how many are accounted for at the plant that built cars like yours. When I say cars like yours, I mean a: **1970 DODGE Coronet R/T 440 Convertible.**

In August of 2024 I have added another page to the paperwork you receive from us, the number of vehicles accounted for in your make, model and body style (But not engine) in the colors available including the two-tone and special-order colors if available.

Also enclosed is my latest Parts & Services Menu, I highly recommend the Pocket Size White Books, (also available in Large Print) especially the ones related to your vehicle;

- 1962-1974 Part & Casting Numbers Book Volume I,**
- 1962-1974 Part & Casting Numbers Book Volume II,**
- 1966-1968 Production Option Code Book.**
- 1969-1971 Production Option Code Book.**
- 1972-1974 Production Option Code Book.**

If there is anything else I can do for you, don't hesitate to write.

Keep the Faith,

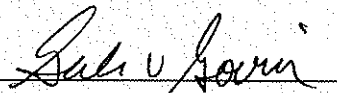

Galen V. Govier  
Managing Member  
GTS. LLC.

ENCLOSURES

GVG/gg