

# Vibration Sensor

## Product Manual

This document applies to products of batch **AA** and onwards (LD 01 20 **AA** 00001). See chapter 2.

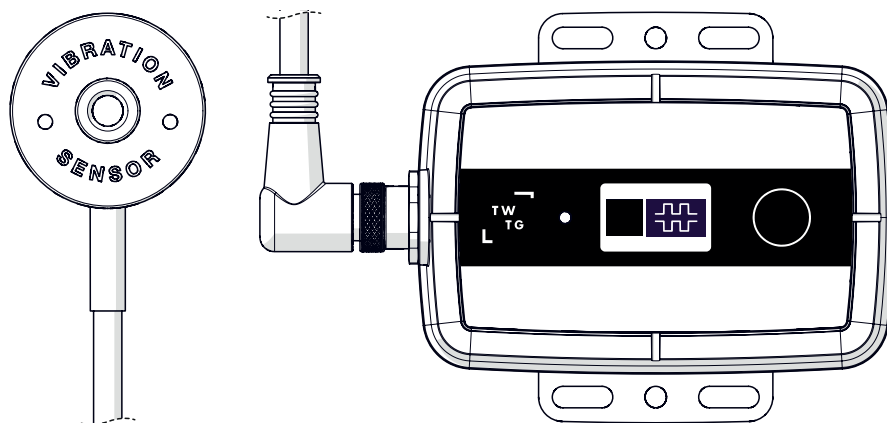

# Contents

|          |   |           |
|----------|---|-----------|
| <b>1</b> | <b>TWTG NEON</b>                                      | <b>4</b>  |
| 1.1      | NEON Product Introduction . . . . .                   | 4         |
| 1.2      | Related Documents . . . . .                           | 4         |
| <b>2</b> | <b>Getting Started</b>                                | <b>5</b>  |
| 2.1      | Compatibility of this manual . . . . .                | 5         |
| 2.2      | What you will need . . . . .                          | 5         |
| 2.3      | What is in the box . . . . .                          | 5         |
| 2.4      | Product Specifications . . . . .                      | 6         |
| 2.5      | Product Type Identification . . . . .                 | 8         |
| 2.6      | Component Names . . . . .                             | 9         |
| 2.7      | Product Dimensions . . . . .                          | 10        |
| 2.7.1    | Transmitter . . . . .                                 | 10        |
| 2.7.2    | Sensor . . . . .                                      | 10        |
| <b>3</b> | <b>Warnings</b>                                       | <b>11</b> |
| 3.1      | ATEX / IECEx . . . . .                                | 11        |
| 3.1.1    | Specific Conditions of Use . . . . .                  | 11        |
| 3.1.2    | Installation . . . . .                                | 11        |
| 3.1.3    | Operation . . . . .                                   | 11        |
| 3.1.4    | Service . . . . .                                     | 11        |
| 3.2      | General . . . . .                                     | 12        |
| 3.2.1    | Transport and Storage . . . . .                       | 12        |
| 3.2.2    | Warranty . . . . .                                    | 12        |
| 3.2.3    | Warranty will be void in case of . . . . .            | 12        |
| <b>4</b> | <b>Provisioning</b>                                   | <b>13</b> |
| 4.1      | User Interface . . . . .                              | 13        |
| 4.2      | Operating the Device . . . . .                        | 13        |
| 4.2.1    | Read device status . . . . .                          | 14        |
| 4.2.2    | Device Activation . . . . .                           | 15        |
| 4.2.3    | Device Deactivation . . . . .                         | 16        |
| 4.3      | Product Identification . . . . .                      | 17        |
| 4.3.1    | NFC . . . . .   | 17        |
| 4.3.2    | Data Matrix Code . . . . .                            | 17        |
| <b>5</b> | <b>Installation of the Transmitter</b>                | <b>18</b> |
| 5.1      | Precautions . . . . .                                 | 18        |
| 5.2      | Mounting Bracket Dimensions . . . . .                 | 18        |
| 5.3      | Installation Methods . . . . .                        | 19        |
| 5.3.1    | Installation using mounting holes . . . . .           | 19        |
| 5.3.2    | Installation using threaded holes . . . . .           | 19        |
| 5.3.3    | Installation using bandclamp . . . . .                | 20        |
| <b>6</b> | <b>Installation of the Vibration Sensor</b>           | <b>21</b> |
| 6.1      | General installation requirements . . . . .           | 21        |
| 6.2      | Vibration Sensor Orientation . . . . .                | 21        |
| 6.3      | Direct installation using the mounting hole . . . . . | 22        |
| 6.3.1    | Dimensions . . . . .                                  | 22        |
| 6.4      | Using Chemically Bonded Adapter . . . . .             | 23        |
| 6.4.1    | Dimensions . . . . .                                  | 23        |
| 6.5      | Using Magnet Adapter (Flat) . . . . .                 | 24        |

---

|           |  |           |
|-----------|--|-----------|
| 6.5.1     | Dimensions . . . . .   | 24        |
| 6.6       | Using Magnet Adapter (Curved) . . . . .                      | 25        |
| 6.6.1     | Dimensions . . . . .   | 25        |
| 6.7       | Connecting the Vibration Sensor to the Transmitter . . . . . | 26        |
| <b>7</b>  | <b>Product Functionalities</b>                               | <b>27</b> |
| 7.1       | Application Event Message . . . . .                          | 27        |
| 7.1.1     | Event-triggers . . . . .                                     | 27        |
| 7.1.2     | Content application event message . . . . .                  | 27        |
| 7.2       | Sensor data message . . . . .                                | 28        |
| 7.3       | Device Status . . . . .                                      | 28        |
| 7.4       | Default Configuration . . . . .                              | 29        |
| <b>8</b>  | <b>Maintenance</b>   | <b>30</b> |
| 8.1       | Battery Specifications . . . . .                             | 30        |
| 8.1.1     | Replacement Interval . . . . .                               | 30        |
| 8.2       | Battery Replacement . . . . .                                | 30        |
| 8.2.1     | Required tools . . . . .                                     | 30        |
| 8.2.2     | Disassembly of device . . . . .                              | 31        |
| 8.2.3     | Built in Self-Test Procedure . . . . .                       | 32        |
| 8.2.4     | Assembly of device . . . . .                                 | 33        |
| <b>9</b>  | <b>Accessories and Spare Parts</b>                           | <b>35</b> |
| <b>10</b> | <b>Declaration of Conformity</b>                             | <b>36</b> |

# 1 TWTG NEON

## 1.1 NEON Product Introduction

NEON stands for a standardised approach to collecting data points from the operational environment and in doing so, creates a general approach to integrated solutions within existing IT ecosystems.

The TWTG NEON product range supports all industrial customers moving towards LoRaWAN as the Industrial IoT network of the future.

The LoRaWAN network gives industrial operations a secure solution, which scales-up to tens of thousands of sensors, covers complete sites with only a small amount of gateways and best of all – the low-power approach means that the lifetime of the NEON products can be extended dramatically.

## 1.2 Related Documents

| Document Name                  | Document Number   |
|--------------------------------|---|
| NEON Data Sheet                | 6016_P20-002_Data-Sheet-NEON-Vibration-Sensor             |
| NEON Communication Protocol    | 6013_P20-002_Communication-Protocol-NEON-Vibration-Sensor |
| 3M Scotch Weld Epoxy Datasheet | DP8405NS Green  |

Table 1: Related Documents

## 2 Getting Started

### 2.1 Compatibility of this manual

This manual is meant to be used with products of from a specific production batch. See [Product Type Identification](#) for an explanation on how to retrieve the production batch code from the serial number.

This manual is applicable to:

- Production Batch: **AA** only
  - Example serial number: LD0120**AA**00001

### 2.2 What you will need

In order to deploy the NEON Transmitter, a compatible and operational LoRa-WAN network architecture is required. This manual does not contain any instructions of how-to set-up and install LoRa-WAN networks.

TWTG offers radio network planning and IT architecture design services to fully integrate the products in the NEON product line.

### 2.3 What is in the box

When the product is delivered check the components for damage and if all box items mentioned below are included.

| Box Items                 |  |
|---------------------------|--|
| NEON Transmitter          | 2 batteries, included in the product<br>1 mounting bracket, mounted on the product<br>M12 connector O-ring, mounted on the product |
| NEON Vibration Sensor     | M6 Bolt  |
| Declaration of Conformity | Declaration of Conformity, containing a link to the latest version of this product manual and other relevant product documentation |

**Table 2:** Box Items

## 2.4 Product Specifications

| <b>Product</b>                      |  |
|-------------------------------------|--|
| Product name                        | TWTG NEON Vibration Sensor                 |
| Type identification Transmitter     | DS-LD-01-01                                |
| Type identification Sensor          | DS-VB-01-01                                |
| <b>Environmental conditions</b>     |  |
| Ambient temperature range           | -40 °C - 80 °C                             |
| Storage temperature range           | 10 °C - 30 °C                              |
| Water & dust resistance             | IP65                                       |
| <b>Mechanical (Transmitter)</b>     |  |
| Material                            | Molded plastic                             |
| Weight (including mounting bracket) | 245 g                                      |
| Dimensions                          | 100x70x45 mm                               |
| <b>Mechanical (Sensor)</b>          |  |
| Material                            | Stainless steel and polyurethane           |
| Weight                              | 560 g                                      |
| Dimensions                          | ∅40x21 mm                                  |
| Cable length                        | 3 m  |
| <b>Installation</b>                 |  |
| Transmitter                         | Band clamp or bolts (not included)         |
| Sensor                              | Bolt                                       |
|                                     | Chemically bonded adapter (not included)   |
|                                     | Magnet for curved surfaces (not included)  |
|                                     | Magnet for flat surfaces (not included)    |
| <b>Certifications</b>               |  |
| ATEX certificate number             | DEKRA 20ATEX0098 X                         |
| IECEX certificate number            | IECEX DEK 20.0056X                         |
| Ex marking                          | Ex II 2G Ex ib IIC T4 Gb                   |
| Applicable ATEX/IECEX standards     | EN 60079-0<br>EN 60079-11                  |
| IMDA Dealer License                 | DA108442                                   |
| CE                                  | EN 300 220-1<br>EN 300 220-2<br>EN 300 330 |
| Safety                              | EN 62368-1<br>EN 62311<br>EN 60529         |
| EMC                                 | EN 301 489-1<br>EN 301 489-3               |

**Table 3:** Product specifications. See also "NEON datasheet" in [Related Documents](#) for a detailed overview of specifications.

| Connectivity            |                           |
|-------------------------|---------------------------|
| Protocol                | LoRa-WAN                  |
| Frequency band          | 863-870 MHz               |
|                         | 902-928 MHz (compatible)  |
| Maximum RF output power | +13 dBm                   |
| Provisioning            |                           |
| QR / Serial number      | Serial number (read only) |
| NFC                     | Serial number (read only) |

**Table 4:** Product specifications. See also "NEON datasheet" in [Related Documents](#) for a detailed overview of specifications.

## 2.5 Product Type Identification

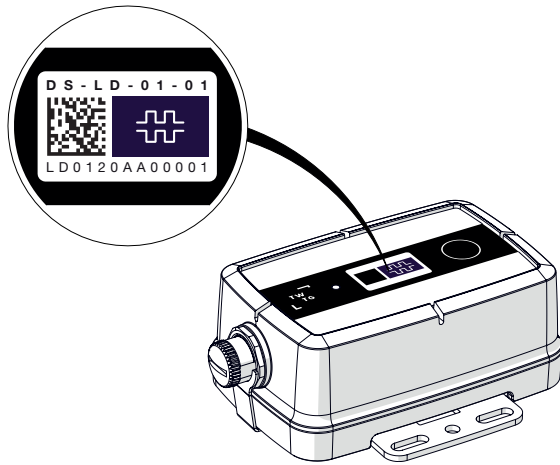

### AA-BB-CC-DD

|                      |                  |
|----------------------|------------------|
| AA - Product Family  | DS               |
| BB - Product Variant | LD = Transmitter |
| CC - Main Revision   | Eg. 01           |
| DD - Region          | 01 = Europe, 868 |

Product Nomenclature

### AA-BB-CC-DD-EEEE

|                       |                  |
|-----------------------|------------------|
| AA - Product Variant  | LD = Transmitter |
| BB - Product Revision | Eg. 01           |
| CC - Production Year  | Eg. 20 = 2020    |
| DD - Production Batch | Eg. AA           |
| EEEE - Serial Number  | Eg. 00001        |

Serial Number

Figure 1: Transmitter product identification

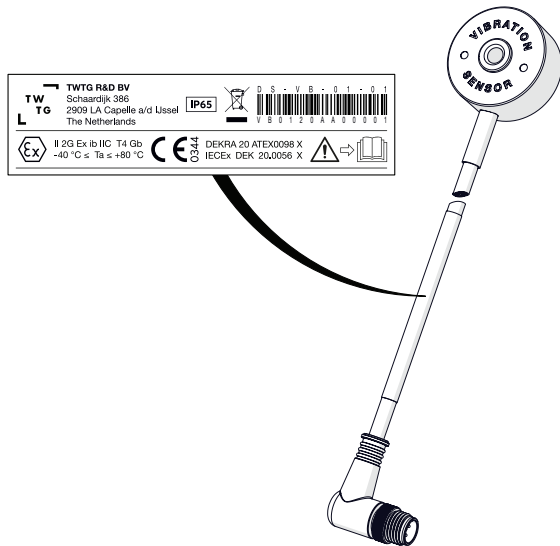

### AA-BB-CC-DD

|                      |                       |
|----------------------|-----------------------|
| AA - Product Family  | DS                    |
| BB - Product Variant | VB = Vibration Sensor |
| CC - Main Revision   | Eg. 01                |
| DD - Region          | 01 = Europe, 868      |

Product Nomenclature

### AA-BB-CC-DD-EEEE

|                       |                       |
|-----------------------|-----------------------|
| AA - Product Variant  | VB = Vibration Sensor |
| BB - Product Revision | Eg. 01                |
| CC - Production Year  | Eg. 20 = 2020         |
| DD - Production Batch | Eg. AA                |
| EEEE - Serial Number  | Eg. 00001             |

Serial Number

Figure 2: Vibration Sensor product identification

## 2.6 Component Names

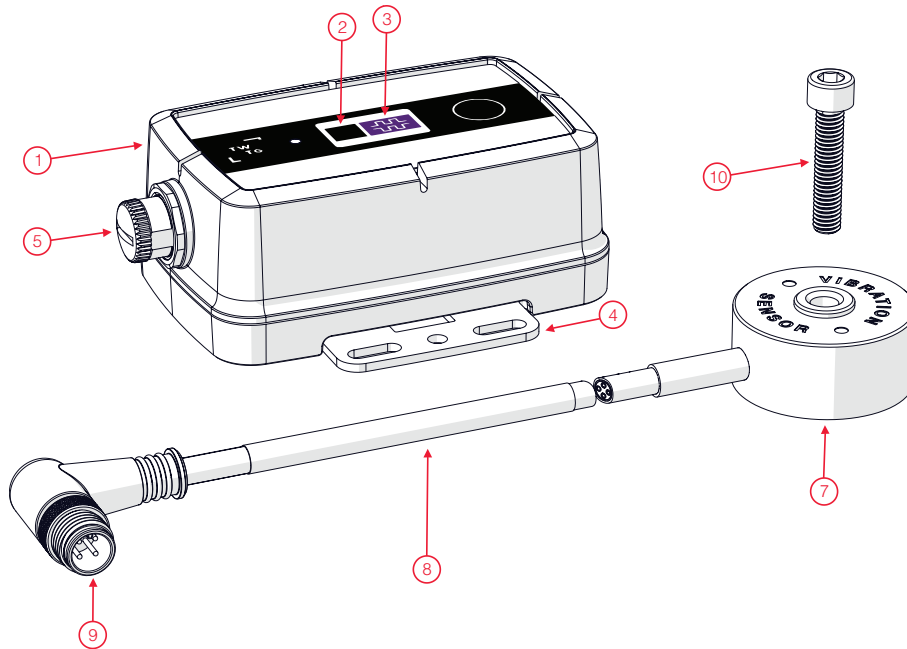

Figure 3: Component Names

| Number | Description            |
|--------|------------------------|
| 1      | Neon Transmitter       |
| 2      | Data Matrix Code       |
| 3      | NFC Tag                |
| 4      | Mounting Bracket       |
| 5      | Earthing Bracket       |
| 6      | M12 Connector Dust Cap |
| 7      | Vibration Sensor       |
| 8      | Sensor Label           |
| 9      | Sensor (M12) Connector |
| 10     | M6 Bolt                |

Table 5: Component Names

## 2.7 Product Dimensions

### 2.7.1 Transmitter

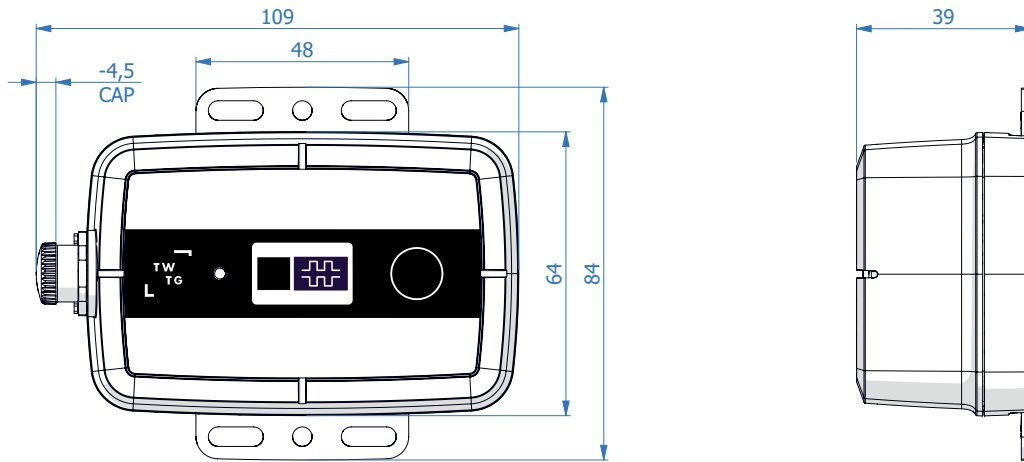

Figure 4: Neon Transmitter Dimensions (mm)

### 2.7.2 Sensor

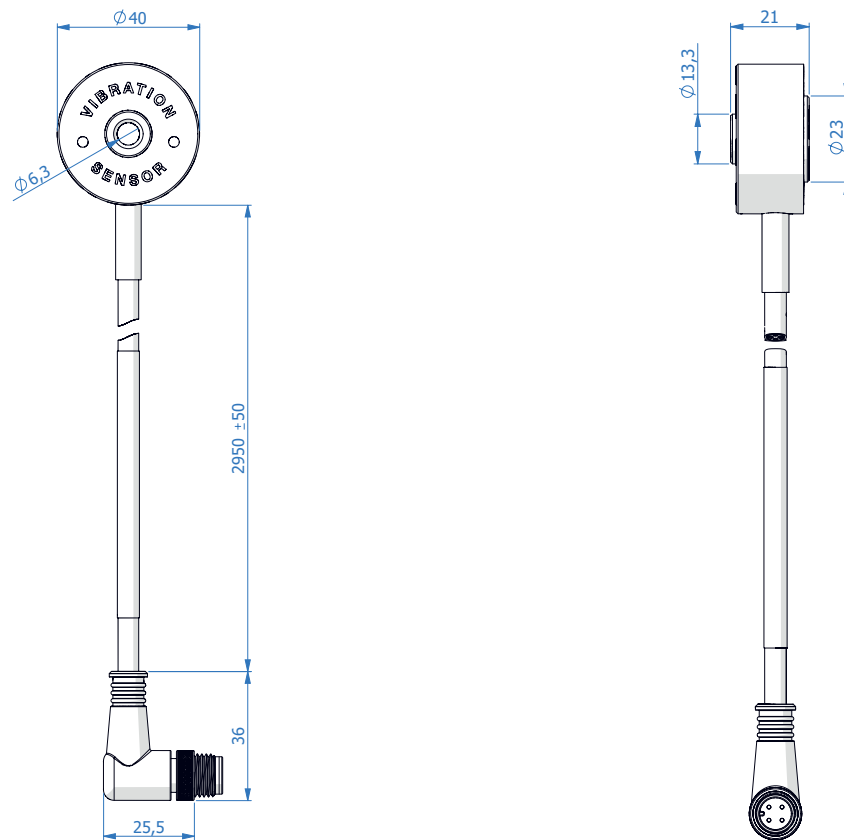

Figure 5: Neon Vibration Sensor Dimensions (mm)

## 3 Warnings

### 3.1 ATEX / IECEx

#### 3.1.1 Specific Conditions of Use



#### **WARNING - POTENTIAL ELECTROSTATIC CHARGING HAZARD**

---

- The product shall be installed in such a way that the risk for electrostatic discharges is minimised;
  - When the equipment is used in hazardous locations, avoid any actions which generate electrostatic discharge;
    - Cleaning: The equipment shall only be cleaned using a wet cloth;
    - Installation: Touch non-metallic parts with an insulating object;
    - Environment: Do not use the product in environments with powerful charge generating processes.
- 

#### 3.1.2 Installation

- This equipment shall be installed according to NEN-EN-IEC 60079-14 and the installation instructions;
- This equipment is intended for fixed installations only;
- This equipment is intended for use in restricted access areas only .



#### **WARNING - DO NOT OPEN WHEN AN EXPLOSIVE ATMOSPHERE IS PRESENT**

---

- Under no circumstances shall the equipment enclosure be opened within a hazardous area
- 

#### 3.1.3 Operation

The connector of this equipment may only be used with external equipment as listed in the “Product Matrix”;

- The connector of this equipment shall not be connected when an explosive atmosphere is present;
- This equipment shall only be used in environments where electromagnetic field strength is limited according to EN 60079-14;
- This equipment is only intended for use in combination with NFC Forum Tag 2 Type technical specification compatible readers;
- This equipment shall only be used within ambient temperatures between -40 °C and 80 °C.

#### 3.1.4 Service

- This equipment shall only be opened by TWTG or by a competent instructed person;
  - The battery is serviceable by said persons;
  - Only replace the battery in a non-hazardous location;
  - Only use SAFT LS17500 batteries;
- If damage to the enclosure is evident, a trained and competent person shall be immediately informed, who shall remove the device from service as soon as possible;
- If the equipment is or has been in contact with chemical materials, clean it appropriately.

## 3.2 General

### 3.2.1 Transport and Storage

- The product must be kept in its original packaging until it reaches the installation site to prevent damage while in transit;
- The storage location must be dry;
- The product must not be exposed to vibrations or impact during transit and storage.

### 3.2.2 Warranty

- The warranty covers the period noted on the quotation;
- If the device doesn't function as documented, the customer should contact TWTG and provide the following information:
  - Model specification;
  - Serial number;
  - Circumstances under which the problems developed;
  - Any previously generated data;
- The party responsible for the costs of solving the problem shall be determined by TWTG on the basis of an investigation conducted by TWTG.

### 3.2.3 Warranty will be void in case of

- Malfunction due to ignoring the design specifications;
- Malfunction due to modification of the product carried out by the user;
- Deferred maintenance of the product or the installation location.

## 4 Provisioning

### 4.1 User Interface

The product contains one Light Emitting Diode (LED) to communicate with the user. In order to interact with the device a button is present on the right side of the NFC label.

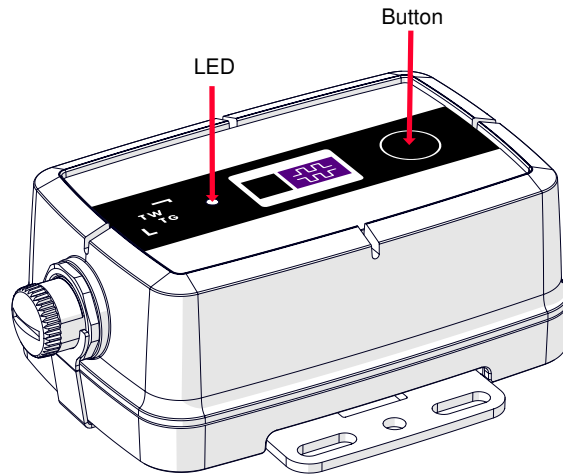

Figure 6: NEON Transmitter Interface

### 4.2 Operating the Device



Press and Release



Press and Hold



Release



Red (Blink 2x)  
Deactivated

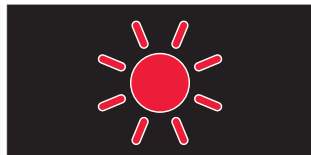

Red (Illuminated)  
Failed



Green (Blink 2x)  
Activated



Green (Illuminated)  
Passed



White (Blinking)  
Connecting



White (Illuminated)  
Calibrating

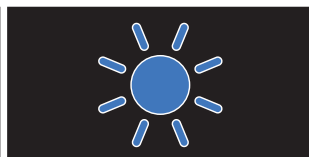

Blue (Illuminated)  
Action / Handling Required



Blue (Flashing each second)  
Button is being hold

### 4.2.1 Read device status

1. Press & release the button and the device will immediately show its status:

- 2.1 Green (Illuminated): Device is activated
- 2.2 Red (Illuminated): Device is deactivated

If the device is activated it will try to send the Device Status message over LoRa (using default configuration):

- 3. White (Blinking): Connecting to network

Within a typical maximum of 3 minutes\*, the device will show:

- 4.1 Green (Blink 2x): Message sent, or
- 4.2 Red (Blink 2x): Failed to connect to send message / connect to network

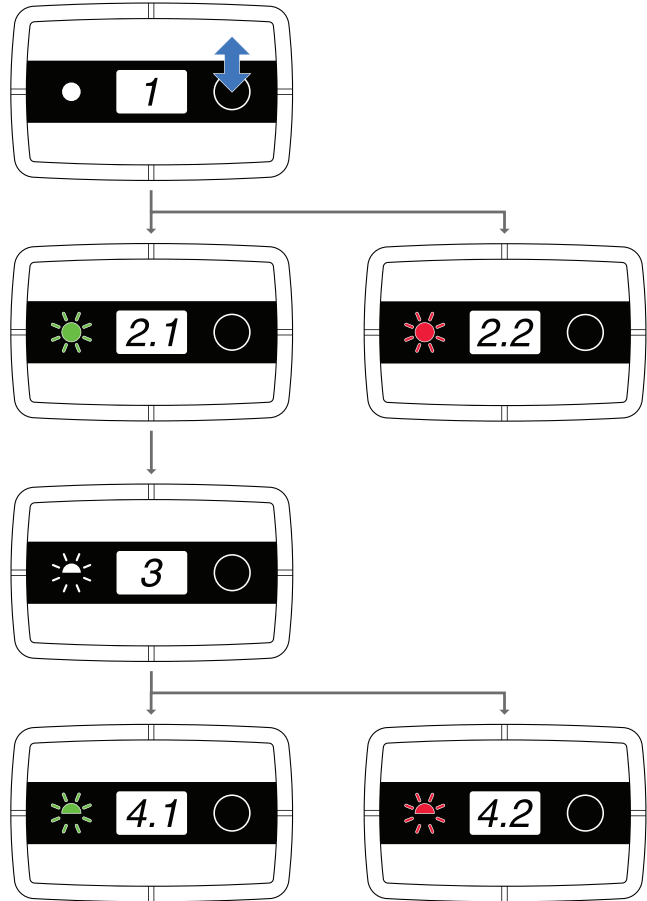

Notes:

- The NEON Transmitter can be configured to send a Sensor Data message upon a button press. In this configuration the Sensor Data message will be sent after the Sensor Event message;
- \*All timeout and retry values are valid for the default configuration, the maximum timeout might be longer when process is performed repeatedly due to RF duty cycle limitations.

### 4.2.2 Device Activation

**1. Press & hold the button for 5 seconds**

During the button hold the LED will blink Blue each second.

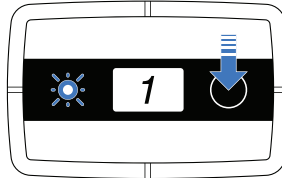

**2. After holding the button for 5 seconds the device will first check the LoRa network:**

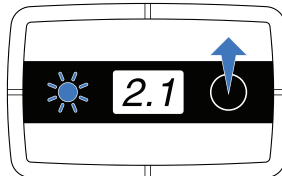

- **3.1 White (Blinking):** Checking LoRa network

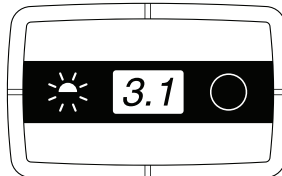

**4. Within a typical maximum of 3 minutes\* the device will show:**

- **4.1 White (Illuminated):** Checking sensor communication
- **4.2 Red (Blink 2x):** Check network

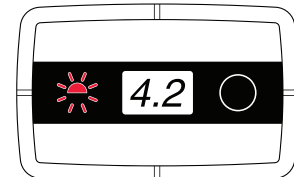
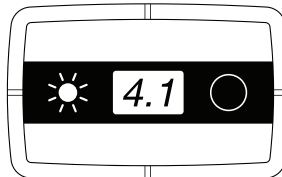

**5. Within 30 seconds max. the device will show:**

- **5.1 White (Blinking):** Sending activation over LoRa
- **5.2 Red (Blink 2x):** Check sensor

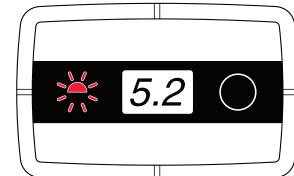
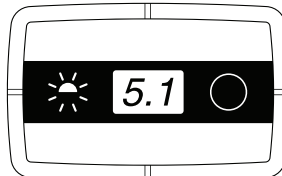

**6. After communicating over LoRa, within a typical maximum of 3 minutes\*, the device will show:**

- **6.1 Green (Illuminated):** Activated, or
- **6.2 Red (Blink 2x):** Check network

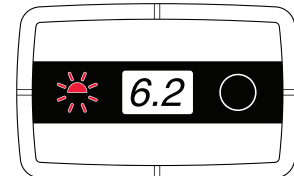
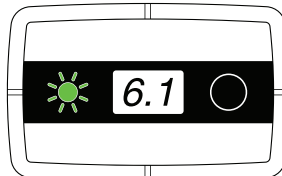

*Notes:*

- *\*All timeout and retry values are valid for the default configuration, the maximum timeout might be longer when process is performed repeatedly due to RF duty cycle limitations.*

### 4.2.3 Device Deactivation

#### 1. Normal Configuration

During the button hold the LED will blink Blue each second.

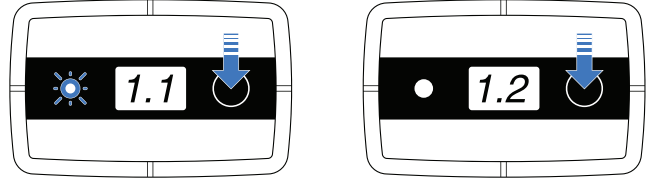

2. After holding the button for 5 seconds the device will show:

- 2.1 Blue (Illuminated): Action required

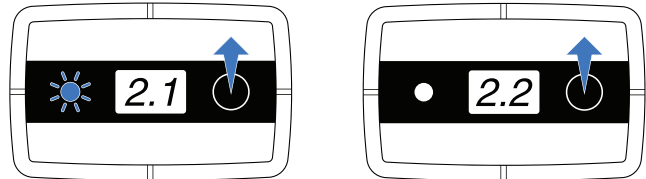

3. The user can now release the button and press and release within 5 seconds:

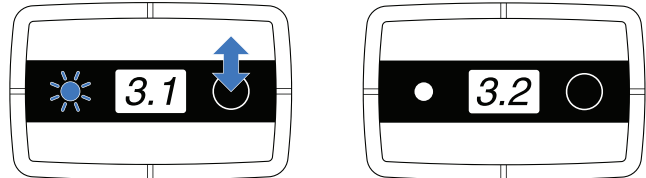

4. If the button isn't pressed & released within these 5 seconds:

- Red (Illuminated): Deactivated
- No LED: Deactivation canceled

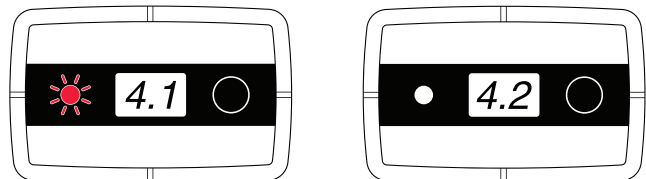

#### Notes:

- Secured Configuration
  - If the device is in Secured Configuration it is not possible to deactivate the device using the button. The device will not react to a press and hold of the button and the LED will stay off. See diagram 1.2, 2.2 and 3.2 and "Communication Protocol" in [Related Documents](#).

### 4.3 Product Identification

#### 4.3.1 NFC

The NFC label is located in the identification sticker and programmed with the serial number of the device. The serial number read from the NFC can be used as unique identifier for provisioning and registration.

#### 4.3.2 Data Matrix Code

The Data Matrix Code label also represents the serial number of the device. The serial number read from the Data Matrix Code code can be used as unique identifier for provisioning and registration. See [Product Type Identification](#) for the a detailed label description.

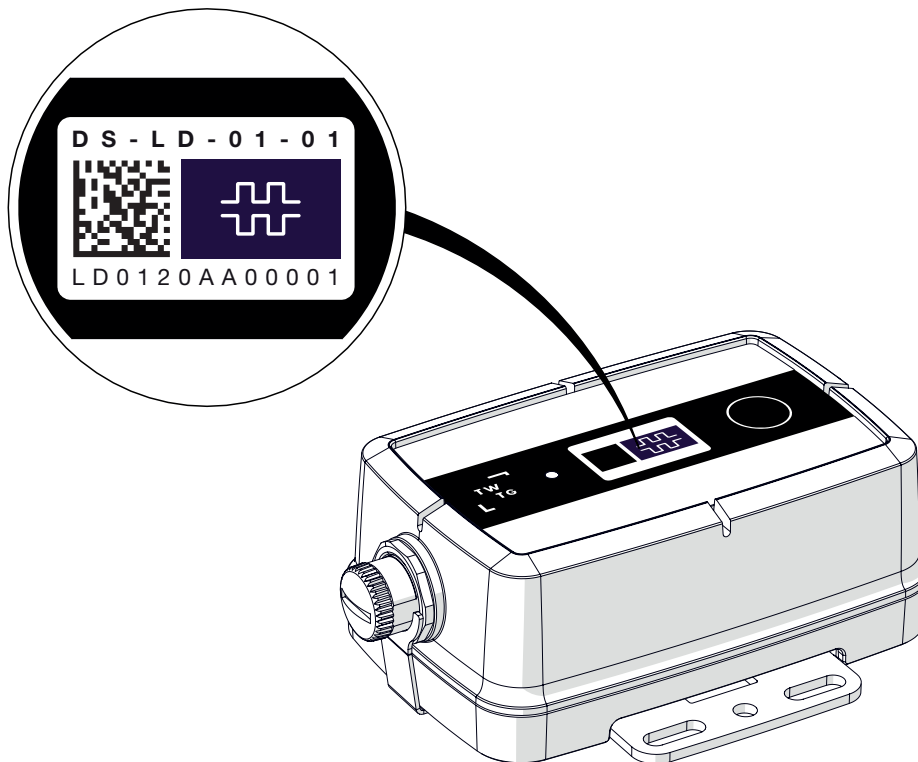

**Figure 7:** NFC and Data Matrix Code code Location

## 5 Installation of the Transmitter

### 5.1 Precautions

#### WARNING

- Avoid placing wiring close to noise sources such as large motors or power supplies;
- Only connect the M12 connector to the Transmitter when there is no explosive atmosphere present;
- The equipment must be installed in accordance with EN 60079-14.

### 5.2 Mounting Bracket Dimensions

git add .

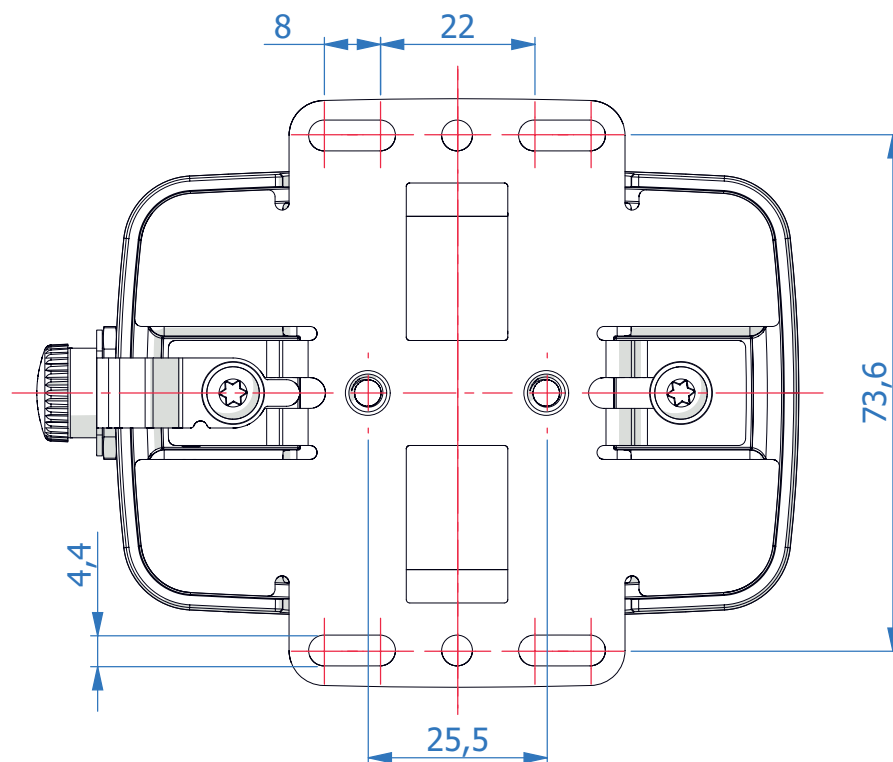

Figure 8: Mounting Bracket Dimensions (in mm)

### 5.3 Installation Methods

#### 5.3.1 Installation using mounting holes

Place the bracket against the (flat) desired surface and use the screw holes or slots to fix in place.

*Note: Slots and screw holes are designed for M4 fasteners.*

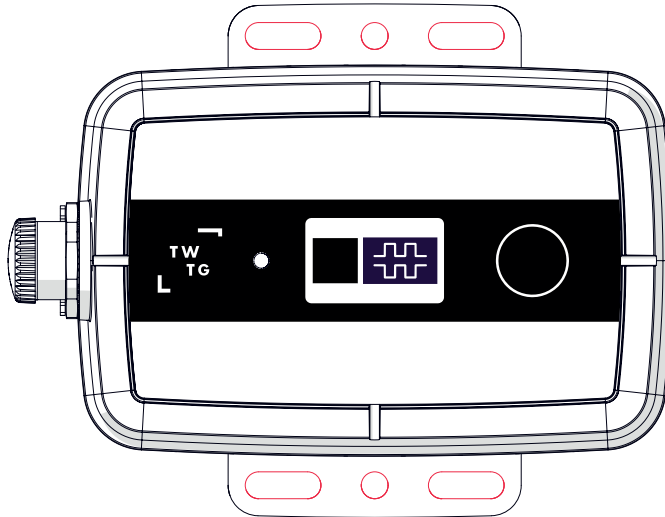

**Figure 9:** Product Mounting Holes

#### 5.3.2 Installation using threaded holes

*Note: Threaded hole accepts M5 bolts.*

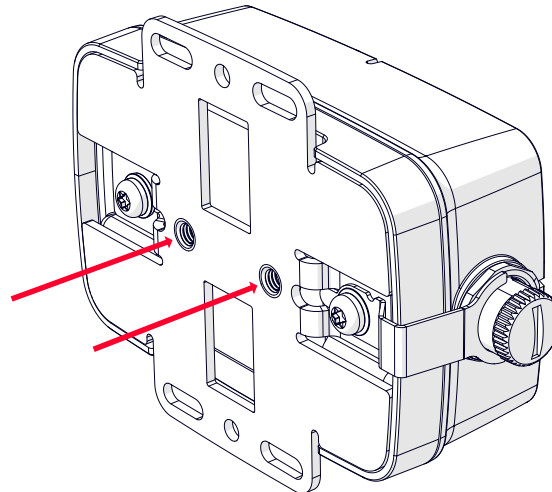

**Figure 10:** Product Threaded Mounting Holes

### 5.3.3 Installation using bandclamp

The Neon Transmitter can be mounted to a pole using a 14 mm wide band clamp, other sizes are not recommended.

**Procedure:**

1. Place the band clamp through the bracket;
2. Place the band clamp around the pole and cut to size;
3. Place the band clamp through the adjustable tightener and fold around the bottom with a plier;
4. Place the band clamp around the pole with the (adjustable) tightener and fix it in place.

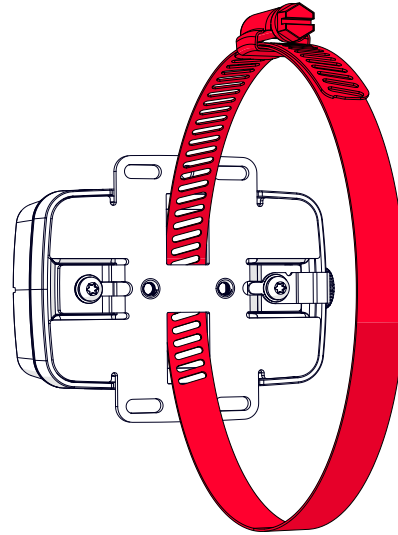

**Figure 11:** Installation using Bandclamp

## 6 Installation of the Vibration Sensor

### 6.1 General installation requirements

#### IMPORTANT

- Always use a torque wrench set to the listed torque to tighten the mounting screw;
- The mounting surface should be flat and always be cleaned before mounting the sensor;
  - Failure to do so may affect measurements;
- Install according to EN 60079-14.

### 6.2 Vibration Sensor Orientation

For correct operation the Vibration Sensor needs to be mounted in the correct orientation. Use the cable as a reference for the Y-axis direction.

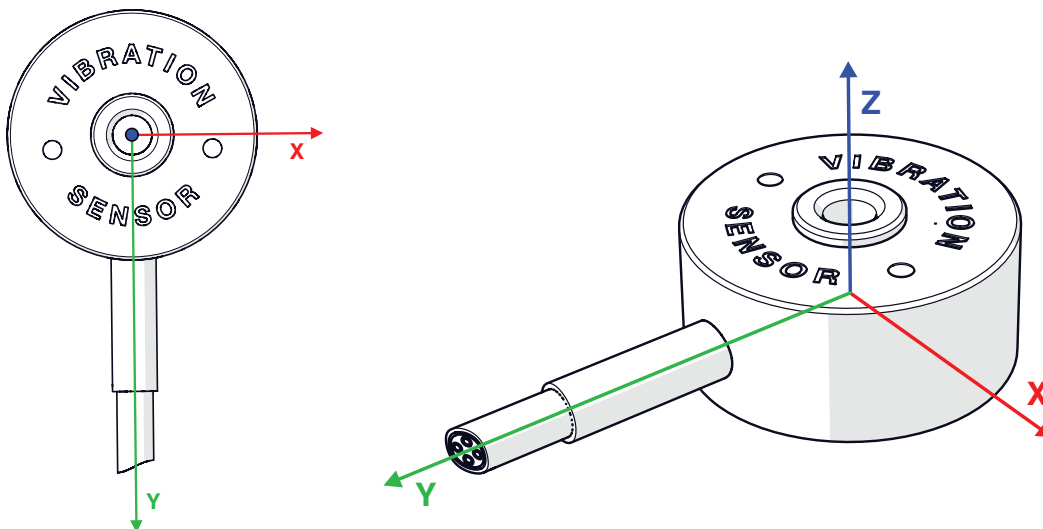

Figure 12: Mounting Orientation

### 6.3 Direct installation using the mounting hole

#### Procedure:

1. Find a flat surface of at least 40 mm in diameter;
2. The surface should be flat, undamaged and clean;
3. Create a threaded hole, size M6 with a thread depth of at least 8 mm;
4. Attach the Vibration Sensor using the supplied M6 bolt and washer, according to [Direct Mounting Assembly](#);
5. Ensure proper orientation according to [Vibration Sensor Orientation](#);
6. Tighten the screw using a torque wrench:
  - Minimum torque: 14 Nm;
  - Maximum torque: 16,3 Nm.

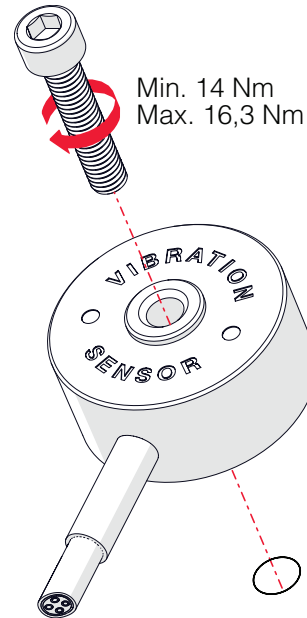

Figure 13: Direct Mounting Assembly

#### 6.3.1 Dimensions

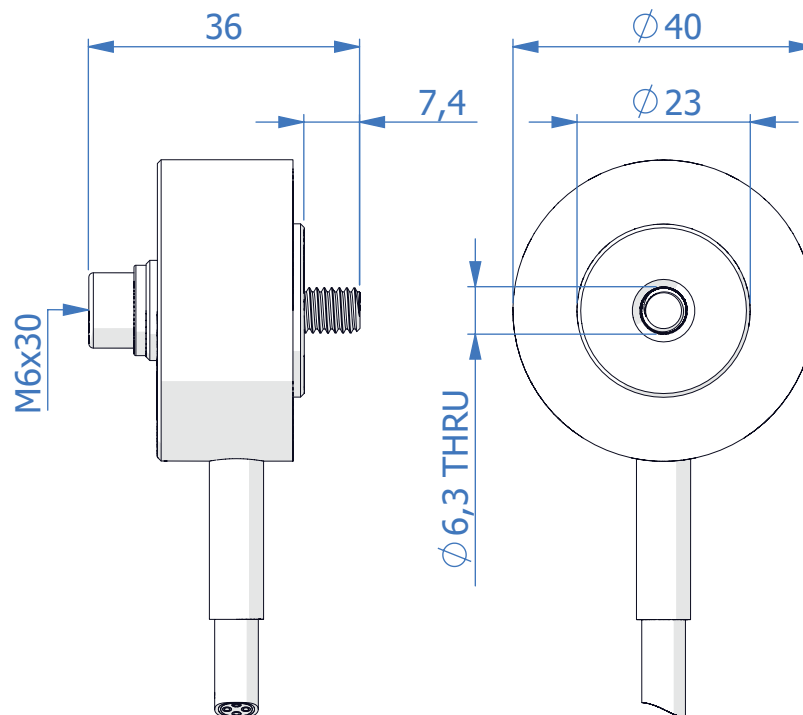

Figure 14: Direct Mounting Dimensions (mm)

## 6.4 Using Chemically Bonded Adapter

### Procedure:

1. Find a flat and surface of at least 40 mm in diameter;
2. See "3M Scotch Weld Epoxy Datasheet" in [Related Documents](#) on how to prepare the surface;
3. Use "3M DP8405 Green" Acrylic Adhesive and compatible dispenser products. Attach adapter to the surface according to "3M Scotch Weld Epoxy Datasheet" in [Related Documents](#). Make sure the adapter is parallel to the mounted surface;
4. Let the adhesive cure for the time as stated in the "3M Scotch Weld Epoxy Datasheet";
5. Attach the Vibration Sensor to the adapter using the supplied M6 bolt and washer, according to [Chemically Bonded Adapter Assembly](#);
6. Ensure proper orientation according to [Vibration Sensor Orientation](#);
7. Tighten the screw using a torque wrench:
  - Minimum torque: 14 Nm;
  - Maximum torque: 16,3 Nm.

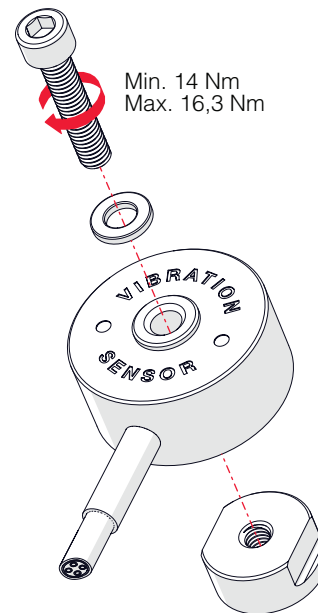

Figure 15: Chemically Bonded Adapter Assembly

### 6.4.1 Dimensions

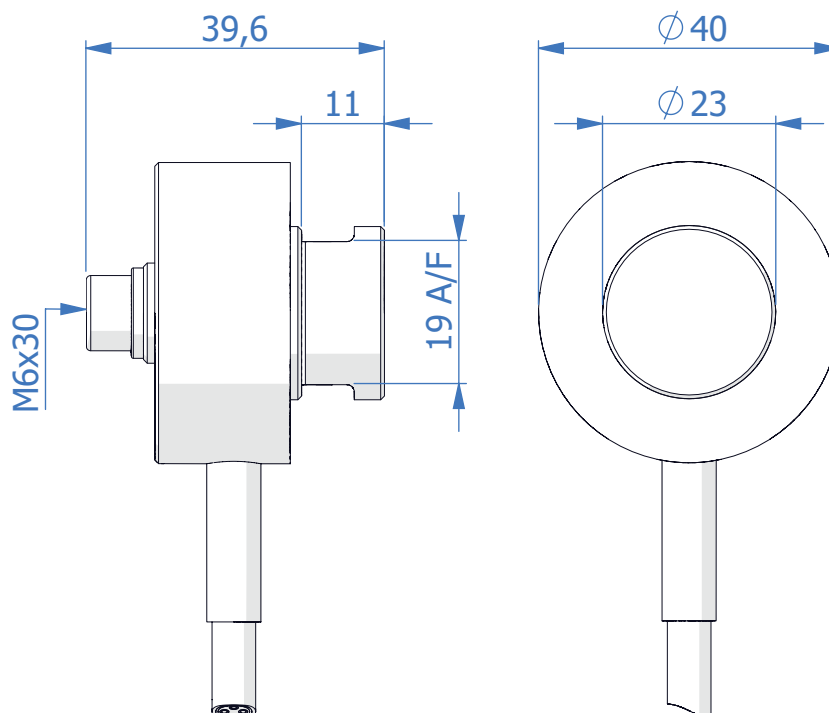

Figure 16: Chemically Bonded Adapter Dimensions (mm)

## 6.5 Using Magnet Adapter (Flat)

### Procedure:

1. Hold the Magnet Adapter in position, using the proper tool;
2. Attach the Vibration Sensor using the supplied M6 bolt and washer, according to [Curved Magnet Adapter Assembly](#);
3. Tighten the screw using a torque wrench:
  - Minimum torque: 14 Nm;
  - Maximum torque: 16,3 Nm;
4. Find a flat and surface of at least 40 mm in diameter;
5. The surface should be flat, undamaged, and clean;
6. Attach the Vibration Sensor using the magnet;
7. Ensure proper orientation according to [Vibration Sensor Orientation](#).

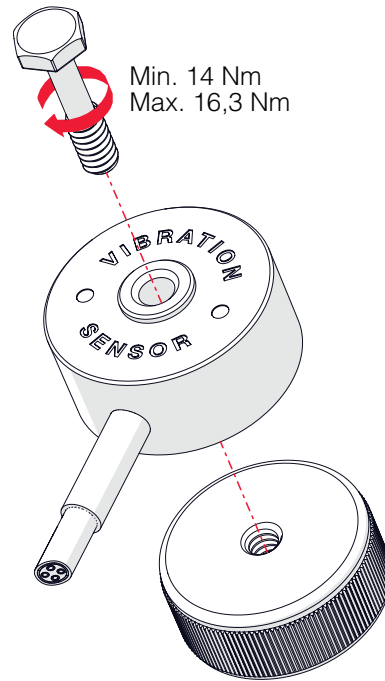

Figure 17: Flat Magnet Adapter Assembly

### 6.5.1 Dimensions

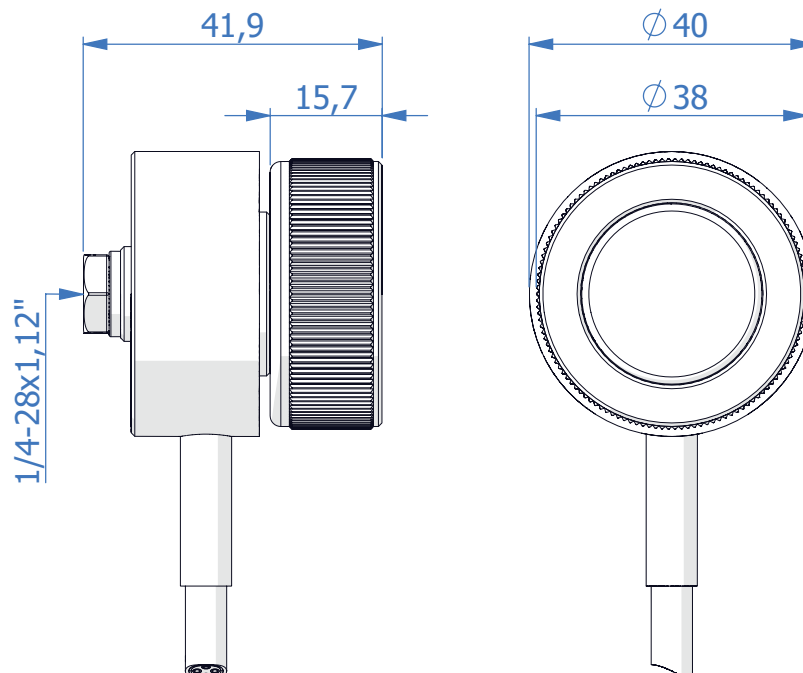

Figure 18: Flat Magnet Adapter Dimensions (mm)

## 6.6 Using Magnet Adapter (Curved)

### Procedure:

1. Hold the Magnet Adapter in position;
2. Attach the Vibration Sensor using the supplied M6 bolt and washer, according to [Curved Magnet Adapter Assembly](#);
3. Tighten the screw using a torque wrench:
  - Minimum torque: 14 Nm;
  - Maximum torque: 16,3 Nm;
4. The surface should be undamaged and clean;
5. Attach the Vibration Sensor using the magnet;
6. Ensure proper orientation according to [Vibration Sensor Orientation](#).

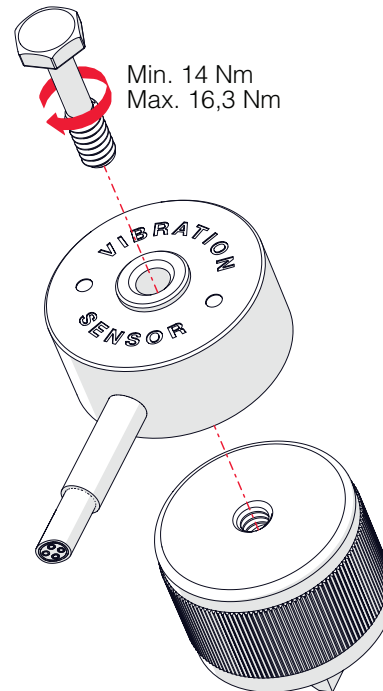

Figure 19: Curved Magnet Adapter Assembly

### 6.6.1 Dimensions

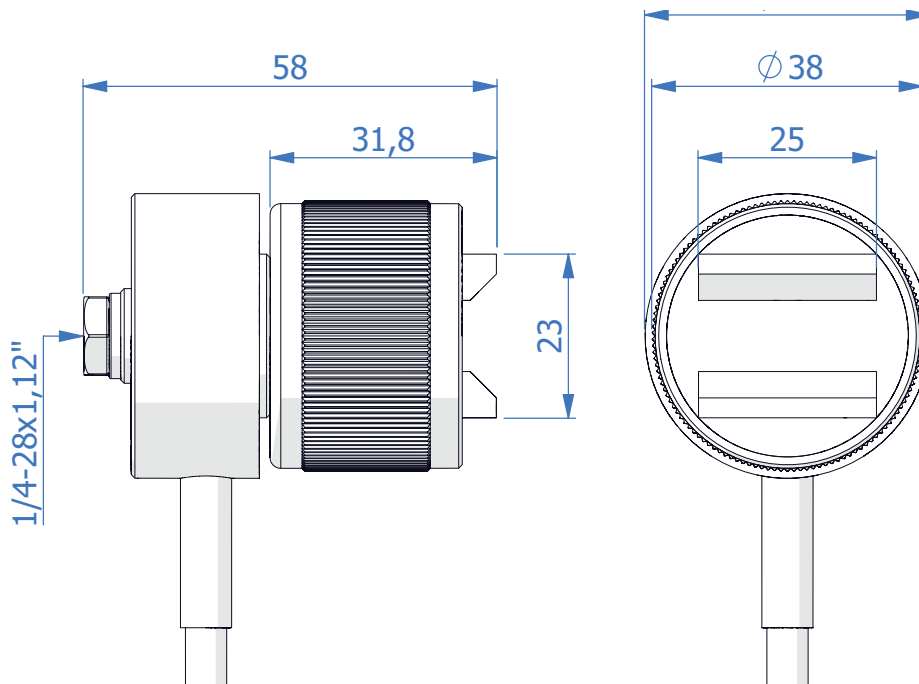

Figure 20: Curved Magnet Adapter Dimensions (mm)

## 6.7 Connecting the Vibration Sensor to the Transmitter

1. Unscrew the dust cap from the product. Check inside the M12 connector for correct placement of the O-Ring (marked in red). Without this O-Ring, the water and dust resistance rating of the product cannot be guaranteed.

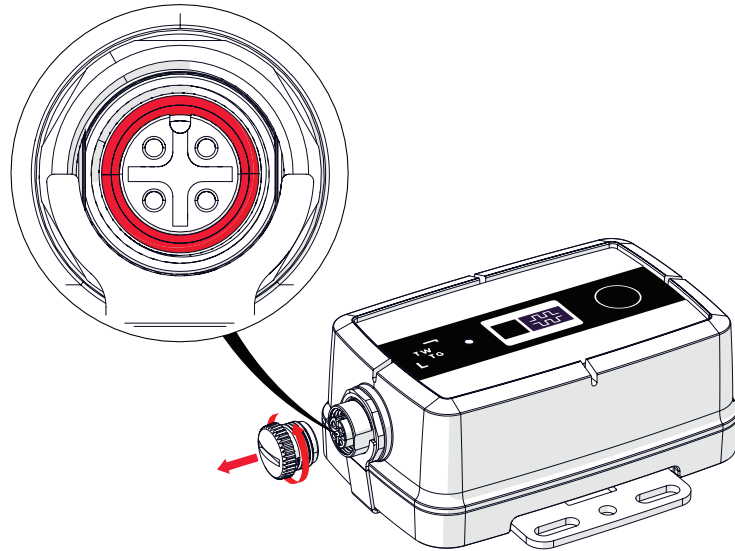

Figure 21: M12 Connector O-ring Location

2. Connect the Sensor connector to the Transmitter. Ensure correct polarity before inserting the connector. The polarity notch is facing up. Completely tighten the connector but do not use excessive force. If the connector is not fully inserted, water and dust resistance rating cannot be guaranteed.

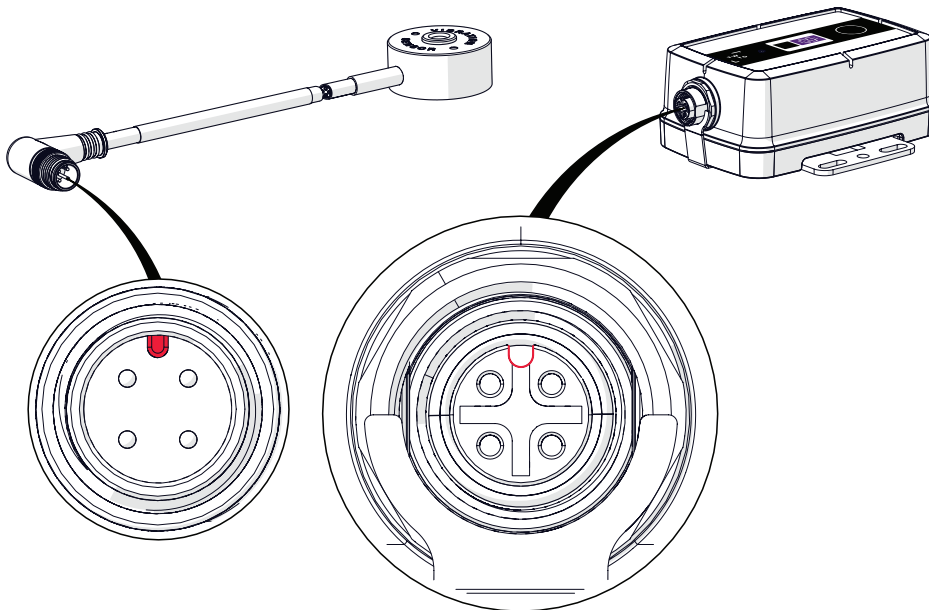

Figure 22: M12 Connector Polarity Mark

## 7 Product Functionalities

A detailed description of setting-up communication and configuring device settings can be found in "Communication protocol", refer to table 1. [Related Documents](#).

### 7.1 Application Event Message

The Vibration Sensor measures and reports the vibrations either by set intervals (a timer-based trigger) or a condition-based trigger.

#### 7.1.1 Event-triggers

Event-messages are triggered on one of the following triggers:

- **Timer (periodic):**

The timer trigger is configurable through the following configurations:

- *measurement\_interval\_seconds*  
Interval in seconds, at which the vibration sensor is read.
- *periodic\_event\_message\_interval*  
Interval in the number of measurements at which the application event messages are periodically sent. The periodic counter is reset on every event message.

- **Condition:**

A condition-based trigger can be either of the following thresholds:

- *rms velocity trigger\_x*
- *peak acceleration trigger\_x*
- *rms velocity trigger\_y*
- *peak acceleration trigger\_y*
- *rms velocity trigger\_z*
- *peak acceleration trigger\_z*

#### 7.1.2 Content application event message

- **Rms velocity**

The measured rms velocity for each of the axis (X,Y,Z) in units of 0.01 mm/s.

- Maximum;
- Average;
- Minimum.

- **Acceleration**

The measured acceleration for each of the axis (X,Y,Z) in units of 0.01 m/s<sup>2</sup>.

- Maximum;
- Average;
- Minimum.

- **Temperature**

The connected sensor temperature in units of 0.1 °C:

- Maximum;
- Average;
- Minimum.

- **Trigger**

Source of the trigger for the application event message:

- "timer" (0);
- "condition\_0" (1);
- "condition\_1" (2);
- "condition\_2" (3);

- "condition\_3" (4).
- **Condition\_n**  
The current state of each condition.

## 7.2 Sensor data message

The FFT (sensor data message) is split between a configurable amount of messages. For a detailed explanation of available configurations see "Communication Protocol" in [Related Documents](#). The sensor data message can be recombined to a full spectrum as shown in figure [Example FFT](#).

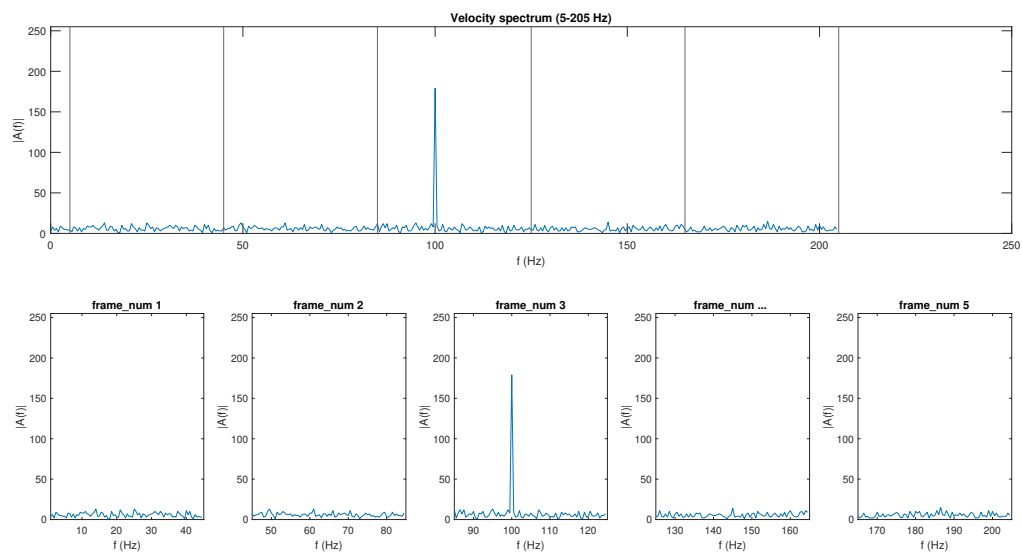

Figure 23: Example FFT

## 7.3 Device Status

Next to reporting the application events, the Vibration Sensor also reports on the device status itself. This is done through a device status messages. A device status message is sent periodically and includes a range of device health parameters, including the following:

- event\_counter;
- battery\_voltage;
- PCB temperature;
- tx\_counter;
- avg\_rssi;
- avg\_snr.

See "Communication Protocol" in [Related Documents](#) for a detailed explanation.

## 7.4 Default Configuration

The Transmitter is delivered with a default configuration. The default configuration includes:

- Measurement interval of 15 mins;
- Event-based message at the time of each periodic trigger with an interval of 16 measurements. ( $16 * 15 = 240$  minutes);
- Device status message interval of 24 hours;
- Enabled event confirmation messages;
- All triggers disabled;
- Disabled data messages confirmation (FFT);
- Disabled FFT.

See "Communication Protocol" in [Related Documents](#) for a detailed explanation of all default configuration values.

## 8 Maintenance

### 8.1 Battery Specifications

| Specifications      |                          |
|---------------------|--------------------------|
| Manufacturer        | Saft                     |
| Part number         | LS-17500                 |
| Quantity            | 2                        |
| Battery Type / Size | Type A                   |
| Chemistry           | Lithium Thionyl Chloride |
| Terminal Type       | Standard                 |
| Dimensions          | 50.9 x 17.13 mm          |
| Battery Life        | >7 years*                |

**Table 6:** Battery Specifications

*\*Note: Applicable to default configuration. Battery lifetime depends on average ambient temperature, network quality and device configuration.*

#### 8.1.1 Replacement Interval

### 8.2 Battery Replacement

The battery can be replaced using the battery replacement kit. See [Accessories and Spare Parts](#). This kit consists of the following parts:

- 2X SAFT LS-17500 battery
- 4X O-Ring
- 1X Gasket



**WARNING - Only use the battery as specified in table 6. Battery Specifications**

#### 8.2.1 Required tools

- Torque screwdriver with TX20 bit;
  - See [Assembly of device](#) for torque settings;
- Loctite 243;
- ESD strap.



**IMPORTANT: ESD Sensitive Electronics**

The product shall be installed in such a way that the risk for electrostatic discharges is minimised.

- Take proper precaution such as a grounded wrist strap and avoid touching the electronics board

### 8.2.2 Disassembly of device



**WARNING - DO NOT OPEN WHEN AN EXPLOSIVE ATMOSPHERE IS PRESENT**

- This equipment shall only be opened by TWTG or by a competent instructed person;
  - The battery is serviceable by said persons;
  - Only use SAFT LS17500 batteries.

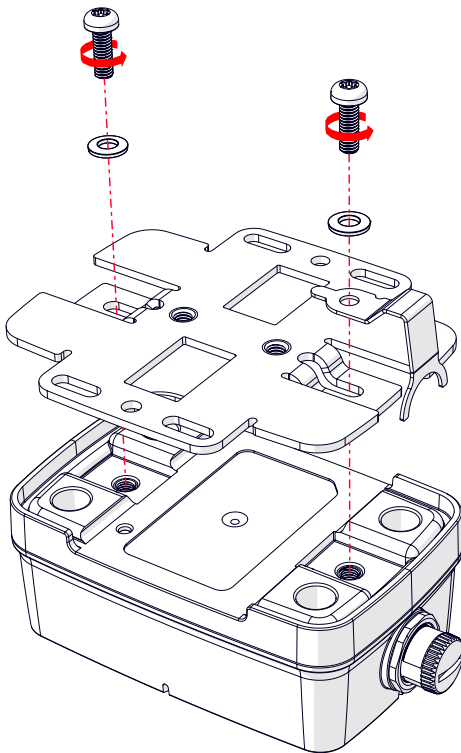

**Step 1:** Remove the two M4 screws and washers fixing the bracket

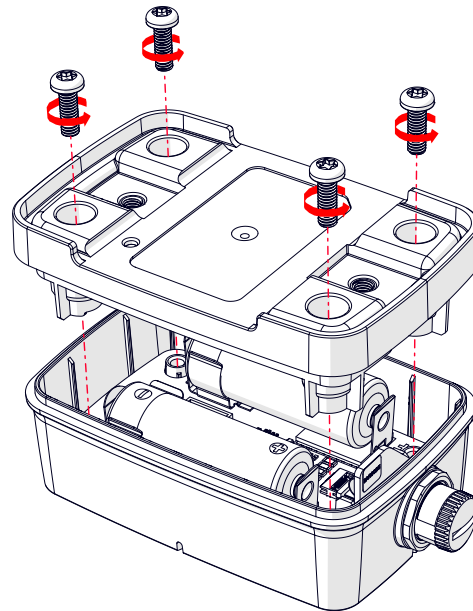

**Step 2:** Remove the four M4 screws and remove the lower housing

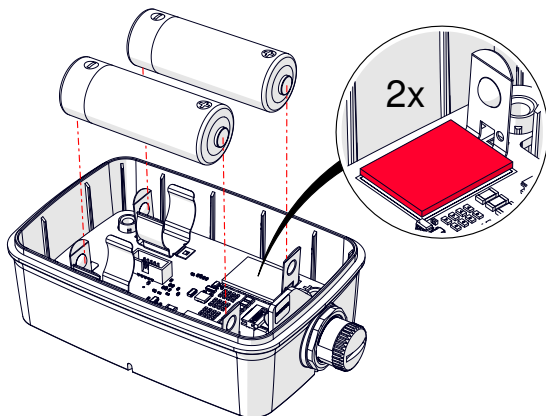

**Step 3:** Remove the batteries, inspect presence of insulating pads, marked in red

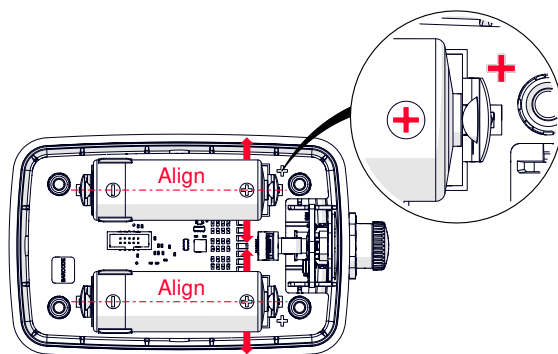

**Step 4:** Place the two new batteries in the battery holder with the positive side facing the positive markings on the circuit board

### 8.2.3 Built in Self-Test Procedure

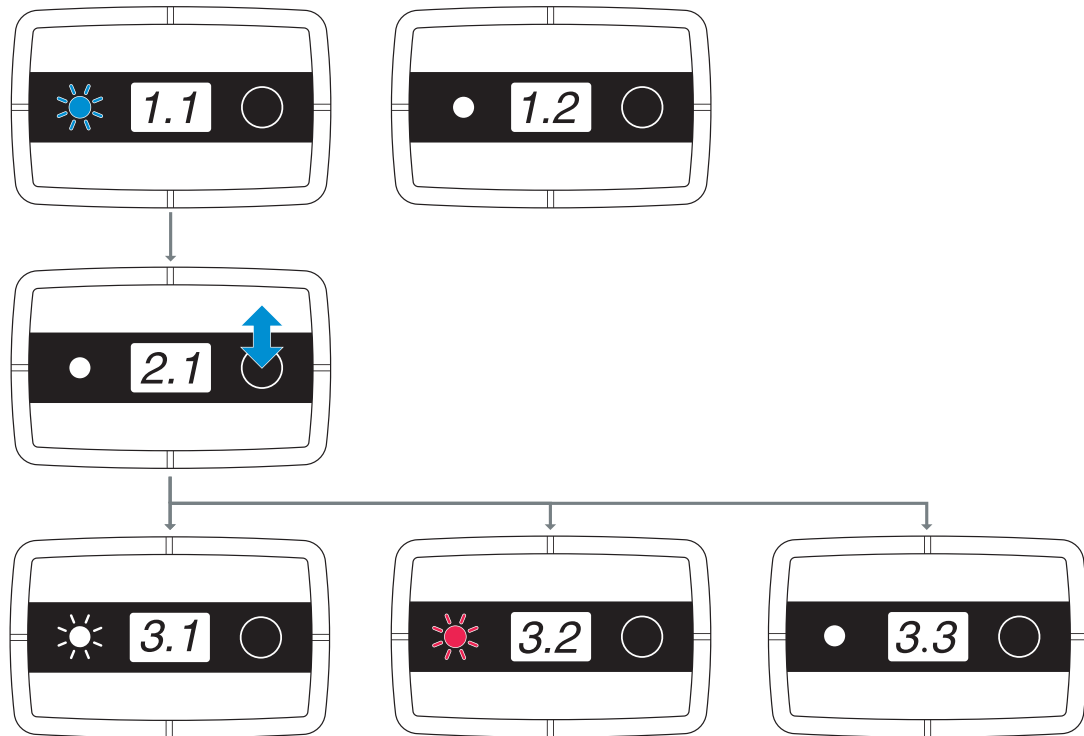

**Figure 24:** Built-in self-test

**1:** After successful replacement of the battery the device will go into self test mode. This mode is activated for 30 seconds;

**1.1:** A BLUE LED will show after inserting the battery;

**1.2:** If no LED is shown, check the battery and / or device;

**2:** Start the test;

**2.1:** Press and Release the button;

**3:** Test Results;

**3.1:** LED turns bright WHITE for 5 seconds. Self test passed;

**3.2:** LED turns RED, self test failed. Check device;

**3.3:** No LED, no response from device. Check device.

After pressing the button once and passing the self-test the device will leave the self-test mode. Pressing the button again will show the device status, as explained in [Read device status](#).

### 8.2.4 Assembly of device

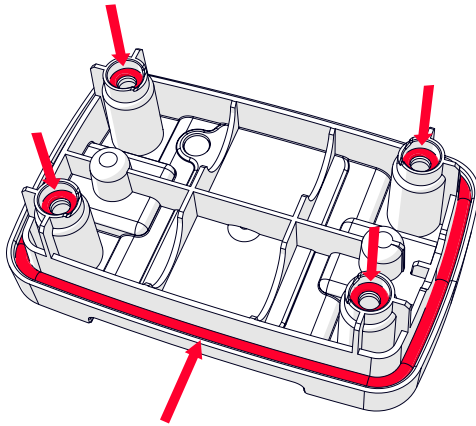

**Step 5:** Replace the 4 O-Rings surrounding the screws and the gasket in the outer edge of the enclosure

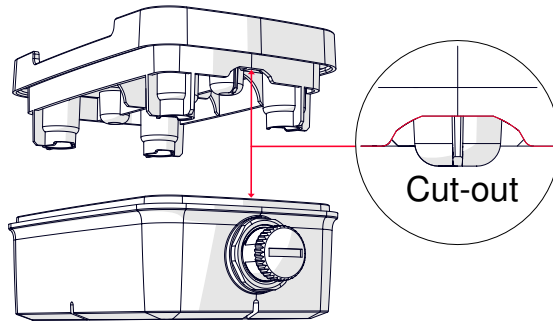

**Step 6:** Place the lower housing back onto upper housing. Please see make sure that the cut out on the lower housing matches the upper housing. Tighten the four screws to fix the lower housing

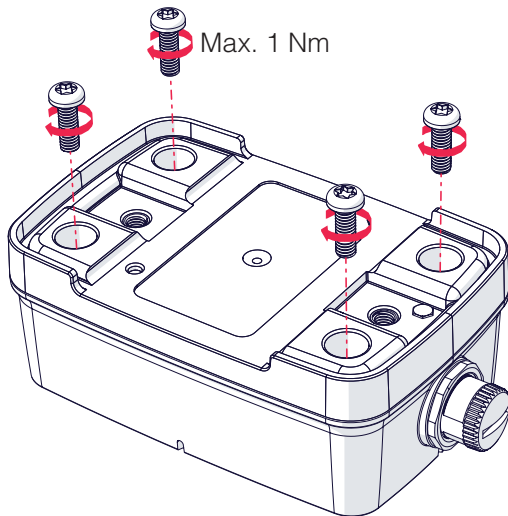

**Step 7:** Tighten the four M4 screws to fix the lower housing

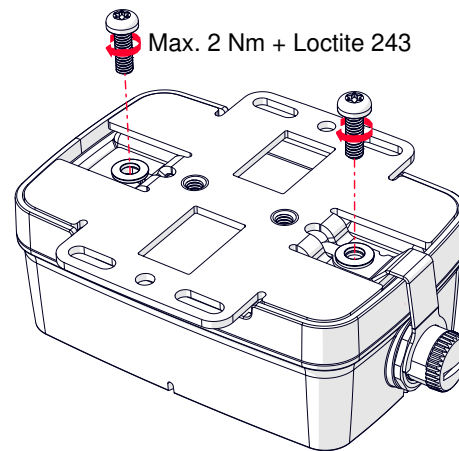

**Step 8:** Tighten the two M4 screws and washers to fix the bracket. Make sure to attach the earthing bracket.

 **WARNING - Ensure proper connection of the earthing bracket**

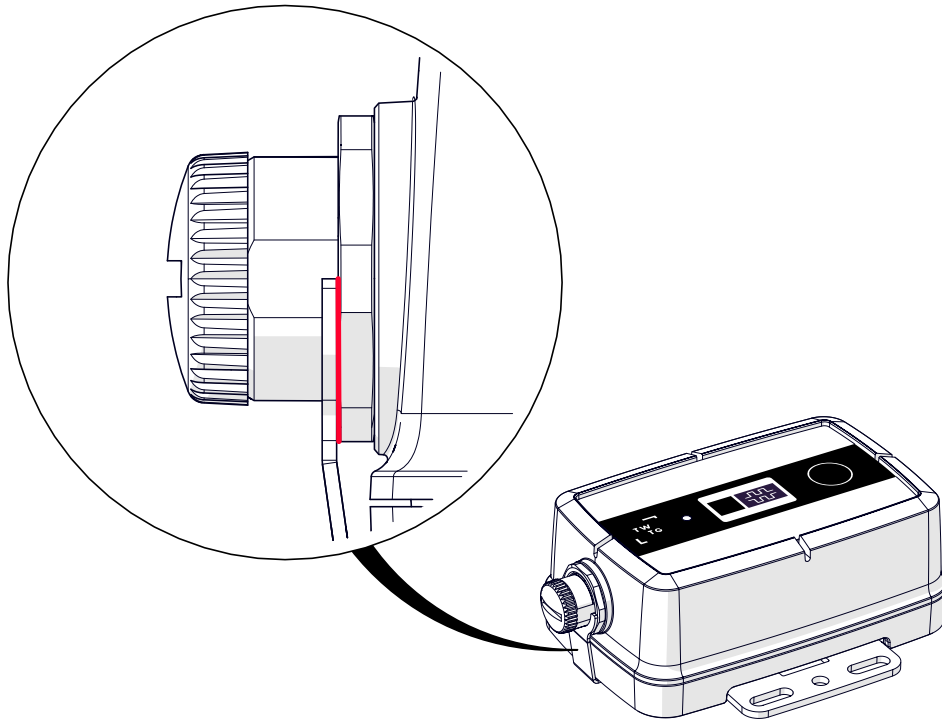

**Step 9:** The bracket must touch the M12 connector

## 9 Accessories and Spare Parts

| Type                                  | Order code                               | Description   |
|---------------------------------------|--|---|
| Battery Replacement Kit               | 5029_P20-002_Battery-<br>Replacement-Kit | Including two batteries, 4 O-Rings, 1 gasket  |
| Chemically Bonded Adapter             | 2013_P20-002_VB-<br>Adapter-Bonded       | Chemically Bonded Adapter   |
| Magnetic Mounting Adapter<br>(Flat)   | 080A122                                  | Flat surface magnet, 1.5" diameter, 50 lbf, 1/4-28 threaded hole w/mounting stud<br>Including mounting bolt   |
| Magnetic Mounting Adapter<br>(Curved) | 080A132                                  | Curved surface magnet, 1.5" diameter, 55 lbf, 1/4-28 threaded hole w/mounting stud<br>Including mounting bolt |

**Table 7:** Available Accessoires & Spare Parts

---

## 10 Declaration of Conformity

This product complies with the following standards:

1. ATEX Directive (2014/34/EU):
  - EN 60079-0:2012 +A11:2013
  - EN 60079-0:2018
  - EN 60079-11:2012
2. Radio Equipment Directive (2014/53/EU):
  - EN 300 220-1 V3.1.1
  - EN 300 220-2 V3.1.1
  - EN 300 330 V2.1.1
  - Draft EN 301 489-1 V2.2.0
  - Draft EN 301 489-3 V2.1.1
  - EN 60529
  - EN 62311:2018
  - EN 62368-1:2014
3. WEEE Directive 2003/1008/EC
4. RoHS (2011/65/EU)

For the full Declaration of Conformity see:

*[www.twtg.io/legal](http://www.twtg.io/legal)*

## Revision

## History

| Revision | Date       | Author(s) | Description  |
|----------|------------|-----------|--|
| A1       | 10-12-2020 | SW, WK    | Concept version  |
| A2       | 02-04-2021 | SW, WK    | Internal review  |
| B        | 06-04-2021 | WK        | First Release  |
| B1       | 08-07-2021 | WK        | Added declaration of conformity<br>Added expected battery life<br>Updated battery replacement UI<br>Updated serial number explanation<br>Added batchcode compatibility |
| B2       | 17-08-2021 | WK        | Updated batch code information   |
| C        | 06-09-2021 | WK        | Release of version C   |
| D1       | 13-10-2021 | WK        | Added EN 300 330<br>Added EN 60529<br>Added IMDA dealer license number   |
| D2       | 15-12-2021 | WK        | Updated Communication Protocol document number   |
| E        | 07-04-2022 | WK        | Release of version E   |