



BEACONS



EB7930 SERIES Pulse[®] II LED Beacon - Severe Vibration

ECCO's Heavy Duty EB7930 Series LED beacons feature encapsulated electronics and are ideally suited to severe vibration applications including mining, construction and waste management. Offering Pulse8 flash pattern and 12-48 VDC operation these, heavy duty beacons also feature a robust reinforced nylon base, both models are available with either a 5" or 7" height profile. Each version offers a combined 3 bolt/1" pipe mounting and a 5-year warranty.

Models

PART NO.	BASE	LENS COLOR OPTIONS	LED COLOR
EB7930X	Polypropylene	<input type="checkbox"/> A <input type="checkbox"/> B <input type="checkbox"/> C <input type="checkbox"/> R <input type="checkbox"/> G	<input type="checkbox"/> C
EB7935X	Polypropylene	<input type="checkbox"/> A <input type="checkbox"/> B <input type="checkbox"/> C <input type="checkbox"/> R <input type="checkbox"/> G	<input type="checkbox"/> C

Replace "X" in part number with desired color: A = amber, B = blue, C = clear, G = green, R = red

Design Features

- 12-48 VDC, 1.3 Amps
- Choose profile height 5" (EB7930) or 7" (EB7935)
- 11 flash patterns
- Encapsulated electronics provide enhanced protection against dust, moisture and vibration
- Epoxy-filled, reinforced polypropylene base, suitable for heavy-duty applications
- Polycarbonate lens
- Temperature Range: -22°F to +122°F (-30°C to +50°C)

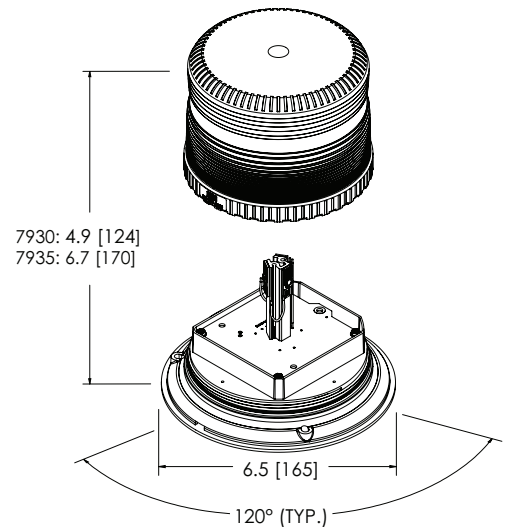

Parts & Accessories

- Lenses: EB7930 - R6050LX
EB7935 - R6070LX