



MINIBARS



DUOBEAM™ SERIES

10" Minibar

The DuoBeam™ Series provide the ultimate level of power, versatility and style available in a LED beacon. The latest high-intensity LEDs produce a powerful, SAE Class I warning signal in a square housing that also offers premium features, including multiple flash patterns and synchronization capability. Featuring 12 VDC operation and 19 flash patterns (single-color or dual-color), the DuoBeam™ Series is suitable for a wide range of applications where a high-intensity SAE Class I light is required.

Models

PART NO.	TYPE	MOUNT	LENS COLOR	LED COLOR
21-DB001-E	4 Bolt or VM	Single	 A	 A
21-DB003-E	4 Bolt or VM	Single	 C	 A
27-DB001-E	4 Bolt or VM	Single	 A	 A
27-DB003-E	4 Bolt or VM	Single	 C	 A

Design Features

- 15' cable, 12 VDC
- 19 flash patterns (single-color or dual-color)
- Standard lightbar mounting, 3 mounting options, carriage bolt
- Temperature Range: -22°F to +122°F (-30°C to +50°C)

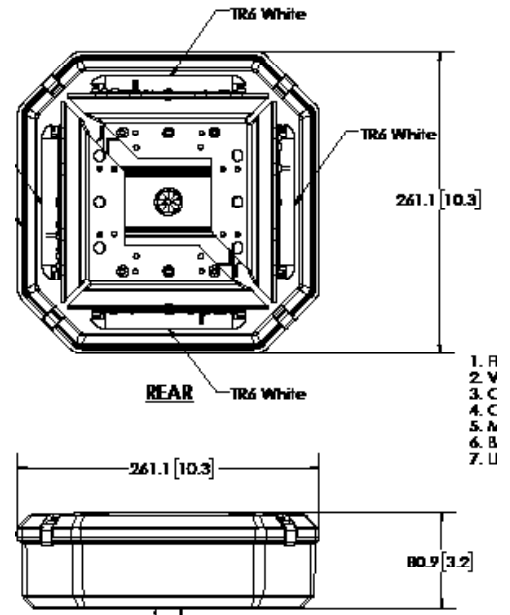

Parts & Accessories

- EZ21DBPM - Pylon Mount
- EZ21DBMIR - Mirror Mount
- EZ21DBMG - Magnet Mount