



## BACK-UP ALARMS



201120  
209120-E  
only

## AUDIBLE SIGNALING DEVICES

### Panel Mount

Warning device intended for in-cab use, panel mounts in 1.25" hole. Piezo electronic design provides very low amp draw.

#### Models

PART NO.	TYPE	VDC	dB(A)
201120	Fast Pulse	12-48	80
202120	Slow Pulse	12-48	80
204120	Dual Mode	12-48	80
209120-E	Continuous	12-48	80
208120	Loud Continuous	12-36	86

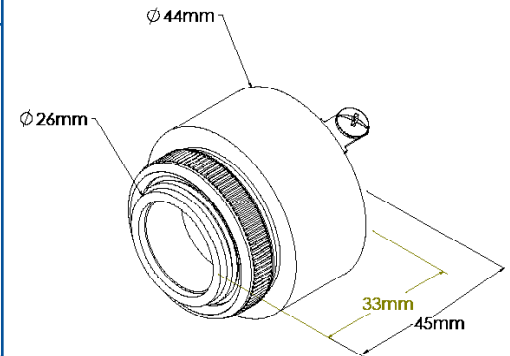

#### Features and Benefits

- 0.1 Amps
- Panel mount 1.25" hole