

# KD18L06

KOHLER® KD SERIES™ ENGINE

KOHLER G-Drive diesel engines produce industry-leading kilowatt displacement in a package that enables a smaller generator set footprint while delivering best fuel consumption at more nodes than any competitor between 700 and 4000 kW. That means higher performance at reduced operating cost. The engine architecture, injection system, and engine management of G-drive engines have been designed to achieve optimal generator set performance while meeting all worldwide emission requirements.

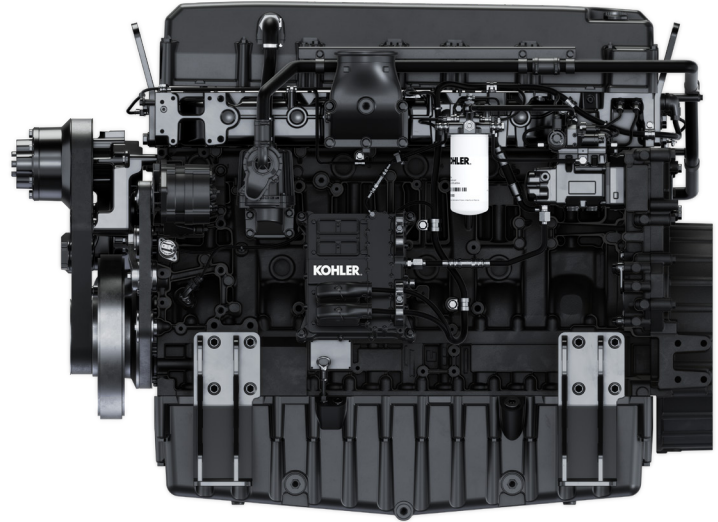

## FEATURES

### Matched Turbochargers

Turbochargers have been designed for maximum power and optimal combustion. They are specifically matched to each engine and engineered to provide the required amount of air at all times, which reduces fuel consumption and enables operation at high altitudes.

### Fuel System

The common rail fuel system generates up to 2200-bar injection pressures for maximum efficiency, optimizing the combustion pressure curve through multiple injections. An ideal injection point and extremely uniform injection quantity create exceptionally low noise and deliver very stable power. Engineers specifically designed the remarkable fuel system to work optimally for KOHLER G-Drive engines.

### Intuitive Engine Control Unit (ECU)

The ECU includes a number of physical parameters for optimal control of the injection system and long-life service. It is designed to work seamlessly within the generator set and to communicate with KODIA, our intuitive diagnostic software, to allow monitoring of the engine performance.

Designed and developed specifically for this engine series, each ECU works with the generator set controller—receiving important engine operating data and allowing the generator set controller to manage the entire system.

### Innovative Cylinder Head Design

Featuring a “crossflow” design and new valve orientation, our innovative cylinder head design includes more efficient fuel delivery, combustion, and exhaust gas flow. High-quality materials were chosen for better performance and a strengthened structure.

### Crankcase ventilation

Enhanced crankcase ventilation enables our engines to operate under the highest temperature fluctuations and prevents heat from affecting power output. This closed-loop regeneration system increases filtration efficiency and results in a more environmentally friendly engine.

**KOHLER®**

# KD18L06

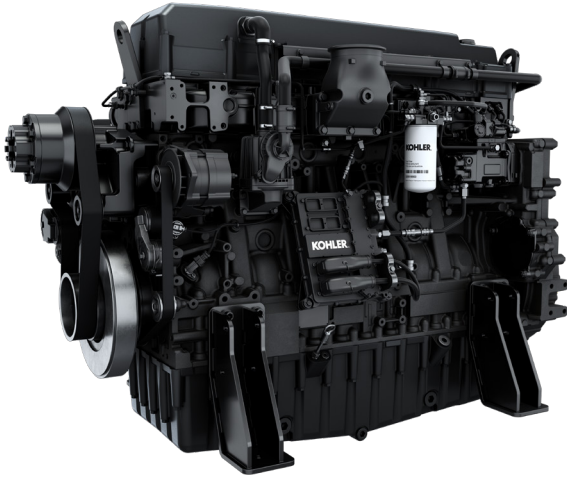

## STANDARD EQUIPMENT

### Induction System

Turbocharged after-cooled; new modular turbocharged system delivers the optimal quantity of air to reach maximum power and reduce fuel consumption during operation.

### Fuel System

The common rail fuel system generates up to 2200-bar injection pressures for maximum efficiency. An ideal injection point and extremely uniform injection quantity create exceptionally low noise and deliver very stable power.

### Cooling System

Water-cooled; thermostat for jacket water cooling system; water pump; radiator-supplied loose incorporating air-to-air charge cooler.

### Lubrication System

Full-pressure water-cooled lubrication system; spin-on lubrication oil filters; oil temperature sensor.

### Starting System

24-volt starting voltage; 140-amp battery-charging alternator.

### Engine Management

The engine control unit (ECU) provides optimal control of the injection system and communicates with KODIA, our intuitive diagnostic software, to allow monitoring of engine performance. The ECU also interoperates with the generator set controller for complete control of the entire system.

## GENERAL DATA

Number of cylinders		6
Cylinder arrangement		6 Inline
Cycle		4-cycle
Bore	mm (in)	148 (5.8)
Stroke	mm (in)	174 (6.9)
Displacement	total L (cu in)	17.960 (1096)
Displacement, cylinder	total L (cu in)	2.99 (182.5)
Lube oil capacity	L	97
Coolant capacity	L	75.7
Flywheel dimensions		SAE 1

## DIMENSIONS AND WEIGHT

Length	mm (in)	1725 (62.9)
Width	mm (in)	1033 (40.7)
Height	mm (in)	1263 (49.7)
Weight, dry	kg (lb)	1997 (4403)

## GROSS POWER

1500 RPM (50 Hz)		
Standby power	kWm/BHP	710/952
Prime power	kWm/BHP	645/865
Continuous power	kWm/BHP	538/721
1800 RPM (60 Hz)		
Standby power	kWm/BHP	820/1100
Prime power	kWm/BHP	745/1000
Continuous power	kWm/BHP	621/833

## RATINGS/POWER DEFINITIONS

### Standby Power

Applicable for supplying power to varying electrical loads for the duration of power interruption of a reliable utility source. Standby power is in accordance with ISO 8528. Fuel stop power in accordance with ISO 3046, AS 2789, DIN 6271, and BS 5514.

### Prime Power

Applicable for supplying power to varying electrical loads for unlimited hours. Prime power is in accordance with ISO 8528. Ten percent overload capability is available in accordance with ISO 3046, AS 2789, DIN 6271, and BS 5514.

### Continuous Power

Applicable for supplying power continuously to a constant electrical load for unlimited hours. Continuous power in accordance with ISO 8528, ISO 3046, AS 2789, DIN6271, and BS 5514.