

eurotech

A RAYNOR GROUP COMPANY

ADAPT-HI / ADAPT-MID

ASSEMBLY INSTRUCTIONS
OPERATING INSTRUCTIONS
WARRANTY

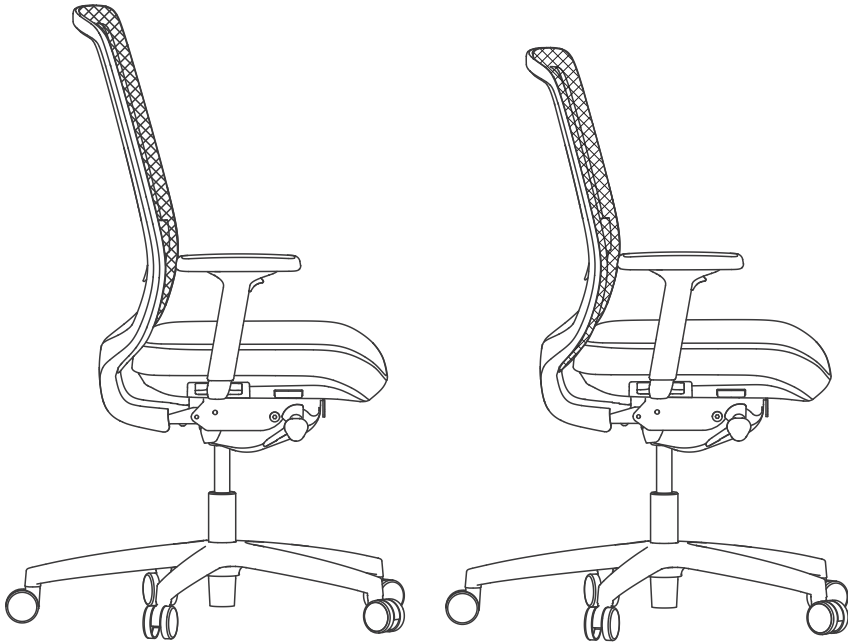





CUSTOMER SERVICE: parts@raynorgroup.com
CUSTOMER SERVICE: 1-800-637-0005
www.eurotechseating.com

ASSEMBLY INSTRUCTIONS

ADAPT-HI / ADAPT-MID

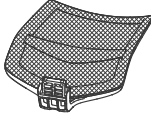
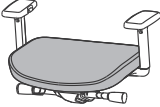
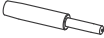
Remove all items from the carton. Verify all pieces before assembly.

PARTS LIST

Key	Description	Part	Qty.	Spare
A	Backrest		1 pc	
B	Seat Cushion with Armrests		1 pc	
C	Gas Lift		1 pc	
D	Base with Castors		1 pc	
E	Back Screws M8*16mm, Blue		3 pcs	1pc
F	Allen Wrench		1 pc	

PREVENTIVE FACINTENANUE AND WARNING!

- USE THIS PRODUCT ONLY FOR SEATING ONE PERSON AT A TIME.
- DO NOT USE THIS CHAIR AS A STEP STOOL / LADDER.
- DO NOT SIT ON ANY PART OF THE CHAIR EXCEPT THE SEAT.
- DO NOT USE CHAIR ON UNEVEN FLOOR SURFACES.
- DO NOT USE CHAIR UNLESS ALL BOLTS, SCREWS AND KNOBS ARE TIGHTENED.
- EVERY SIX MONTHS, PLEASE MAKE SURE ALL BOLTS, SCREWS AND KNOBS ARE FULLY TIGHTENED TO ENSURE STABILITY.
- IF ANY PARTS ARE MISSING, BROKEN, DAMAGED OR WORN, STOP USE OF THE PRODUCT UNTIL REPAIRS ARE MADE USING FACTORY AUTHORIZED PARTS.
- DISPOSE OF PACKAGING PROPERLY. PLASTIC BAG IS NOT A TOY. DO NOT USE PLASTIC BAG AS HEAD COVERING — IT MAY CAUSE SUFFOCATION.
- FAILURE TO FOLLOW THESE WARNINGS COULD RESULT IN SERIOUS INJURY.
- NOTE: SOME SCREWS MAY BE PREASSEMBLED. IF PREASSBABLED, IGNORE ASSEMBLY INSTRUCTIONS.

ASSEMBLY INSTRUCTIONS

ADAPT-HI / ADAPT-MID

Remove all items from the carton. Verify all pieces before assembly.

STEP 1

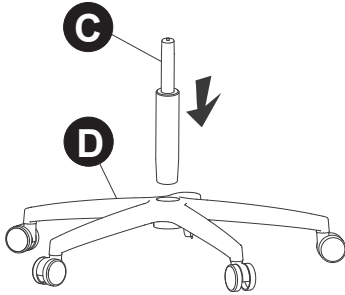

Turn the Star Base (D) upright and insert Gas Lift (C) into the center hole of Star Base (D).

STEP 2

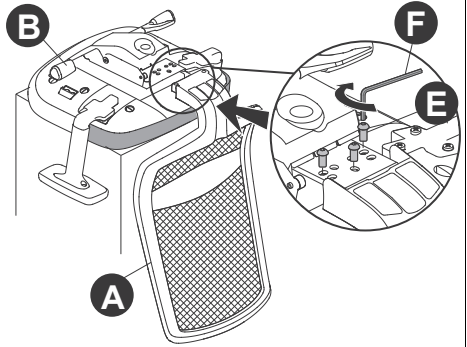

Assemble Backrest (A) to Seat Cushion (B) and secure in place using 3 Back Screws (E) as shown. Tighten the screws fully with Allen Wrench (F).

STEP 3

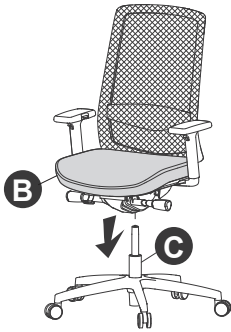

Turn assembled seat upright and locate central hole below Seat Cushion (B) over Gas Lift (C). Push down firmly until connection is secure.

PREVENTIVE FACINTENANUE AND WARNING!

- USE THIS PRODUCT ONLY FOR SEATING ONE PERSON AT A TIME.
- DO NOT USE THIS CHAIR AS A STEP STOOL / LADDER.
- DO NOT SIT ON ANY PART OF THE CHAIR EXCEPT THE SEAT.
- DO NOT USE CHAIR ON UNEVEN FLOOR SURFACES.
- DO NOT USE CHAIR UNLESS ALL BOLTS, SCREWS AND KNOBS ARE TIGHTENED.
- EVERY SIX MONTHS, PLEASE MAKE SURE ALL BOLTS, SCREWS AND KNOBS ARE FULLY TIGHTENED TO ENSURE STABILITY.
- IF ANY PARTS ARE MISSING, BROKEN, DAMAGED OR WORN, STOP USE OF THE PRODUCT UNTIL REPAIRS ARE MADE USING FACTORY AUTHORIZED PARTS.
- DISPOSE OF PACKAGING PROPERLY. PLASTIC BAG IS NOT A TOY. DO NOT USE PLASTIC BAG AS HEAD COVERING — IT MAY CAUSE SUFFOCATION.
- FAILURE TO FOLLOW THESE WARNINGS COULD RESULT IN SERIOUS INJURY.
- NOTE: SOME SCREWS MAY BE PREASSEMBLED. IF PREASSEMBLED, IGNORE ASSEMBLY INSTRUCTIONS.

OPERATING INSTRUCTIONS

ADAPT-HI / ADAPT-MID

A SEAT HEIGHT ADJUSTMENT

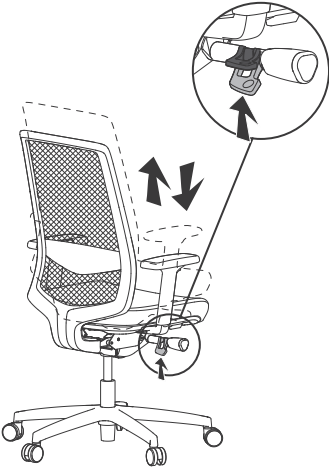

C BACK TILT LOCKOUT

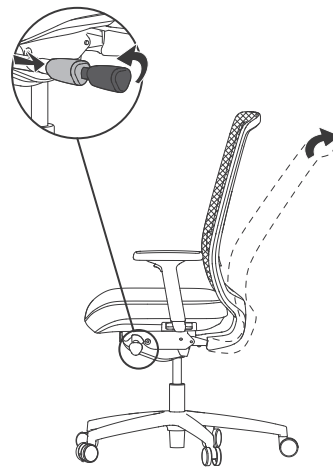

B SEAT DEPTH ADJUSTMENT

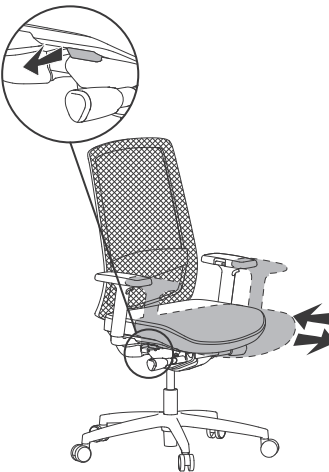

D TILT TENSION ADJUSTMENT

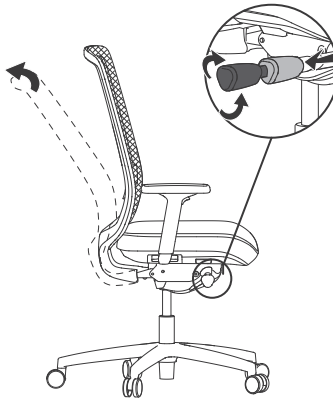

A TO ADJUST SEAT HEIGHT

While seated, lean forward, lifting your body weight from the seat. Reach underneath the right side of chair and locate the lever. Pull the lever upwards slowly to allow the chair to rise to the desired height. To lower seat height, lift the lever slowly while seated.

B TO ADJUST SEAT DEPTH

To move the seat forward or backward, pull the right front handle and position the seat.

C TO ADJUST TILT LOCKOUT

Reach the left side of chair and locate the lever. To lock the chair in a position, set the back at the desired angle and turn the lever backwards. Turn the lever forwards. When the lever is in this position, the back is free to recline backwards.

D TO ADJUST TILT TENSION

Reach the right side of chair and locate the lever. Pull the lever. To loosen the counter pressure of mechanism, turn the lever backwards. To increase the counter pressure of mechanism turn the lever forwards. Rotate the lever until desired counter pressure is reached.

OPERATING INSTRUCTIONS

ADAPT-HI / ADAPT-MID

E LUMBAR SUPPORT HEIGHT ADJUSTMENT



G ARMREST HEIGHT ADJUSTMENT

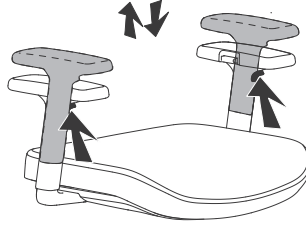

E TO ADJUST LUMBAR SUPPORT

While seated, pull upward and downward the lumbar support to a desired position.

F 360° SWIVEL

Your chair can rotate around 360°.

G TO ADJUST ARMREST HEIGHT

To adjust armrests, pull upwards/downwards while holding down the lock release button located on the front side of the armrest.

H ARM PAD DEPTH ADJUSTMENT

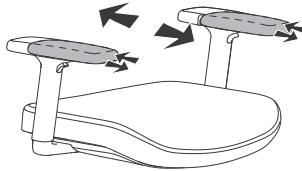

H TO ADJUST ARM-PADS DEPTH

To adjust arm-pads depth press the button located on the inner side of pads and move the pads to a desired position.

F 360° SWIVEL



I ARM PAD WIDTH ADJUSTMENT

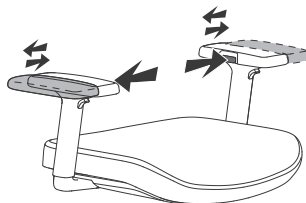

I TO ADJUST ARM-PADS WIDTH

To adjust arm-pads width press the button located on the inner side pads and move the pads to a desired position.

OUR PROMISE.

They say with age comes wisdom. And while we've learned a lot since we sold our first office chair in 1979, even then we knew that superior craftsmanship and design are essential ingredients in delivering real value for our customers. All these years later, those three simple pillars still stand behind our promise of exceptional seating with every chair we sell.

DESIGN CRAFTSMANSHIP VALUE

Eurotech. Sit Smarter.

THE EUROTECH WARRANTY

- For all products except for 24/7 chairs (see below), Eurotech warrants to the original purchaser all components for the life of the product with the exception of upholstery and foam, which will be warranted for five years.
- For 24/7 chairs, Eurotech warrants to the original purchaser of all 24/7 and Big & Tall chairs all components for 5 years with the exception of upholstery and foam which will be warranted for 2 years.
- Eurotech warrants to the original purchaser that all parts will be free from material defects. Eurotech will repair or replace, at its option, any unaltered components.
- Eurotech does not warrant any aftermarket hardware that is installed on the product.
- Eurotech's warranty is limited to the normal use of the product in a forty hour work week and a 275lb. weight limit unless otherwise noted.
- Eurotech shall NOT be liable for consequential or incidental damage arising from any product defect.
- Eurotech's warranty is limited to replacement or repair and does not cover cost of transportation and labor. There are no other warranties expressed or implied other than those specifically described.
- Eurotech does not warrant customers own material.
- Eurotech warrants to the original purchaser with proof of purchase along with a copy of the receipt.
- Arm Pads are warranted for 2 years under normal wear and tear.
- Cylinder is warranted for 5 years.

This warranty is made as of 9/15/16. Please see <http://www.eurotechseating.com/warranty-information> for any updates and/or revisions to this warranty.