



- The RvA is a signatory to the EA MLA.
- The RvA is a signatory to the ILAC MRA.
- The RvA is a signatory to the IAF MLA.

Test report No:
2281846.0501-RSM

TEST REPORT (PARTIAL)

Radio Spectrum Matters (RSM)

(*) Identification of item tested	Lappset Luna play and dance spot
(*) Trademark	Lappset Luna
(*) Model and /or type reference	YA3400
(*) Features	WCDMA Bands B1, B3, B8 LTE Bands B1, B3, B7, B8, B20, B28A.
(*) Derived model(s)	N/A
(*) Applicant's name / address	Lappset Yalp B.V. Nieuwenkampsmaten, 12, 7472 DE Goor, The Netherlands.
Test method requested, standard	ETSI EN 301 908-1 V15.2.1— IMT cellular networks; Harmonised Standard for access to radio spectrum; Part 1: Introduction and common requirements
Verdict Summary	IN COMPLIANCE (refer to chapter 3 for details)
Tested by (name / position & signature)	Miguel M. López Guzmán Technical Professional EMC&RF 
Approved by (name / position & signature)	Sedat Eser Operational Manager EMC&RF 
Date of issue	2024-03-17
Report template No	TRF_RSM_EN301908-1 R1.0 (*) "Data provided by the applicant"

INDEX

Competences and Guarantees.....	3
General conditions.....	3
Uncertainty	3
Environmental conditions	3
Possible test case verdicts.....	4
Definition of symbols used in this test report.....	4
Abbreviations.....	4
Data provided by the applicant.....	6
Document History	6
Conclusion, Remarks and Comments	6
1 General Information	7
1.1 General Description of the Item(s)	7
1.2 Test data.....	8
2 Description of Test Setup.....	9
2.1 Sample(s) used for tests.....	9
2.2 Operating mode(s) used for tests	9
2.3 Test conditions.....	9
3 Verdict summary section.....	12
3.1 Standards	12
3.2 Overview of results – UMTS.....	12
3.3 Overview of results – LTE	12
3.4 Deviation(s) from the Standard(s) / Test Specification(s).....	12
4 Test results – UMTS	13
4.1 Radiated Spurious Emissions (30 - 1000 MHz).....	13
4.2 Radiated Spurious Emissions (1 – 12.75 GHz).....	17
5 Test results. LTE.....	22
5.1 Radiated Spurious Emissions (30 - 1000 MHz).....	22
5.2 Radiated Spurious Emissions (1 – 12.75 GHz).....	26
6 Description of modifications.....	31
6.1 Photos	31
Annex 1: Used Equipment.....	32
Annex 2: Photographs.....	33

COMPETENCES AND GUARANTEES

DEKRA is a testing laboratory competent to carry out the tests described in this report.

In order to assure the traceability to other national and international laboratories, DEKRA has a calibration and maintenance program for its measurement equipment.

DEKRA guarantees the reliability of the data presented in this report, which is the result of the measurements and the tests performed to the item under test on the date and under the conditions stated in the report and it is based on the knowledge and technical facilities available at DEKRA at the time of performance of the test.

DEKRA is liable to the client for the maintenance of the confidentiality of all information related to the item under test and the results of the test.

The results presented in this Test Report apply only to the particular item under test established in this document.

IMPORTANT: No parts of this report may be reproduced or quoted out of context, in any form or by any means, except in full, without the previous written permission of DEKRA.

GENERAL CONDITIONS

1. This report is only referred to the item that has undergone the test.
2. This report does not constitute or imply on its own an approval of the product by the Certification Bodies or Competent Authorities.
3. This document is only valid if complete; no partial reproduction can be made without previous written permission of DEKRA.
4. This test report cannot be used partially or in full for publicity and/or promotional purposes without previous written permission of DEKRA.

UNCERTAINTY

Uncertainties have been calculated according to the DEKRA internal document DEKRA internal document AMS#2224. The reported expanded uncertainties are based on a standard uncertainty multiplied by a coverage factor of $k=2$, providing a level of confidence of approximately 95%. Refer to the Annex 1 for further information.

ENVIRONMENTAL CONDITIONS

The climatic conditions during the tests are within the limits specified by the manufacturer for the operation of the EUT and the test equipment. The climatic conditions during the tests were within the following limits:

Ambient temperature	15 °C – 35 °C
Relative Humidity air	30% - 60%
Atmospheric pressure	86 kPa – 106 kPa

If explicitly required in the basic standard or applied product / product family standard the climatic values are recorded and documented separately in this test report.

POSSIBLE TEST CASE VERDICTS

Test case does not apply to test object	N/A
Test object does meet requirement	P (Pass) / PASS
Test object does not meet requirement	F (Fail) / FAIL
Not measured	N/M

DEFINITION OF SYMBOLS USED IN THIS TEST REPORT

<input checked="" type="checkbox"/> Indicates that the listed condition, standard or equipment is applicable for this report/test/EUT.			
<input type="checkbox"/> Indicates that the listed condition, standard or equipment is not applicable for this report/test/EUT.			
Decimal separator used in this report	<input type="checkbox"/>	Comma (,)	<input checked="" type="checkbox"/> Point (.)

ABBREVIATIONS

For the purposes of the present document, the following abbreviations apply:

EDGE	:	Enhanced Data rates for GSM Evolution
EMC	:	ElectroMagnetic Compatibility
ERM	:	Electromagnetic compatibility and Radio spectrum Matters
EUT	:	Equipment Under Test
E-UTRA	:	Evolved Universal Terrestrial Radio Access (Also known as LTE)
FDD	:	Frequency Division Duplex
FDMA	:	Frequency Division Multiple Access
GSM	:	Global System for Mobile communications
IMT	:	International Mobile Telecommunications (Includes both IMT-2000 and IMT-Advanced RITs)
ITU-R	:	International Telecommunication Union Radio sector
LTE	:	Long Term Evolution (Also known as E-UTRA)
MSG	:	Mobile Standards Group
MSR	:	Multi-Standard Radio
OFDMA	:	Orthogonal Frequency Division Multiple Access
R&TTE	:	Radio Telecommunications and Terminal Equipment
RAT	:	Radio Access Technology
RF	:	Radio Frequency
RIT	:	Radio Interface Technology
RMS	:	Root Mean Square
RRC	:	Radio Resource Control
SDO	:	Standard Development Organization
TDD	:	Time Division Duplex
TDMA	:	Time Division Multiple Access
TFES	:	Task Force for European Standards for IMT
TIA	:	Telecommunications Industry Association
UE	:	User Equipment
UMB	:	Ultra Mobile Broadband
UTRA	:	Universal Terrestrial Radio Access
UWC	:	Universal Wireless Communications
WMAN	:	Wireless Metropolitan Area

DATA PROVIDED BY THE APPLICANT

The following data has been provided by the client:

1. Information relating to the description of the sample ("Identification of the item tested", "Trademark", "Model and/or type reference tested", and "Features").

DEKRA Certification B.V. declines any responsibility with respect to the information provided by the applicant and that may affect the validity of results.

DOCUMENT HISTORY

Report nr.	Date	Description
2281846.0501-RSM	2024-03-17	First release.

CONCLUSION, REMARKS AND COMMENTS

This is a partial test report. Not all the tests requested by the applicable standard have been performed. Please refer to chapter 3 for the applied tests.

The equipment under test (EUT) does meet the requirements of the following tests as detailed in the applicable standard(s):

- Radiated spurious emissions test according to ETSI EN 301 908-1 in worst cases of the report module.

The applicant stated that the RF modules used in the EUT are pre-certified according to the latest applicable version of the standard(s). This is a partial test report and is valid in combination with the RF test report(s) of the RF module used. It encloses the test results given at chapter 4. Refer to this chapter for further details.

1 GENERAL INFORMATION

1.1 General Description of the Item(s)

Description of the item	Lappset Luna play and dance spot
Model / Type number	YA3400
Serial number	YA3400 / 1702
Trademark	Lappset Luna
Manufacturer.....	Lappset Yalp B. V.
Address	Nieuwenkampsmaten 12, 7472 DE Goor The Netherlands

Operating frequency range(s) – Tx :	WCDMA B1, B3, B8 LTE B1, B3, B7, B8, B28A
Operating frequency range(s) – Rx :	WCDMA B1, B3, B8 LTE B1, B3, B7, B8, B28A
Type of Modulation	QPSK, 16QAM, 64QAM
Number of channel.....	---
Antenna type.....	Tango 44
Antenna gain.....	---







Rated power supply	Voltage and Frequency		Reference poles				
			L1	L2	L3	N	PE
	<input checked="" type="checkbox"/>	AC: 100 – 240 V, 50/60 Hz	<input checked="" type="checkbox"/>	<input type="checkbox"/>	<input type="checkbox"/>	<input checked="" type="checkbox"/>	<input checked="" type="checkbox"/>
	<input type="checkbox"/>	DC:					
	<input type="checkbox"/>	Battery:					
Rated Power	150 W						
Clock frequencies	1000 MHz CPU Clock Frequency (PLL) 24 MHz, 25 MHz, 22.5792 MHz						
Other parameters.....	2G, 3G, LTE						
Software version	OS1.0						
Hardware version.....	Luna electronics set 2023/YIN252/Rev102						
Dimensions in mm (W x H x D)....	600mm x 600mm x 230mm						
Mounting position.....	<input type="checkbox"/>	Table top equipment					
	<input checked="" type="checkbox"/>	Wall/Ceiling mounted equipment					
	<input type="checkbox"/>	Floor standing equipment					
	<input type="checkbox"/>	Hand-held equipment					
	<input type="checkbox"/>	Other: pole/column/pipe-mounted					

Intended use of the Equipment Under Test (EUT)
Lappset Luna Interactive dance and play spot, Luna is an interactive playce that magically responds to the players in it. It detects players' movement and reacts with sound and music. Children are encouraged to dance, play, and work together in various games. Every time you enter the field, you will be surprised with games and challenges to discover together.

No	Module/parts of test item	Type	Manufacturer
1	Computer board Luna YIN2	Rev252	KITT Engineering
2	Modem Module LE910C4 XX Linux mPCIe Series 2G 3G LTE	LE910C4XX	TELIT
3	Power Supply	HEP-150-15A	Meanwell
4	Antenna	Tango 44	Siretta
5	Speaker	Control25-1L	JBL
6	Camera	2023 / V3.10	KITT Engineering

Modifications to the test item during testing	<input type="checkbox"/>	N/A	<input checked="" type="checkbox"/>	Refer to the chapter 6
---	--------------------------	-----	-------------------------------------	------------------------



Copy of marking plate:

Model: Lappset Luna
 Model no: YA3400

Made in the Netherlands
www.lappset.com

100-240 V~
 50/60 Hz
 Max. 150 W
 IP54

 c  us
 E107438

Complies with:
 UL-62368-1
 CSA C22.2 No. 62368-1

Contains FCC ID: R17LE910CXNF.
 The device complies with part 15 of the FCC Rules.
 Operation is subject to the following two conditions:
 (1) This device may not cause harmful interference, and
 (2) this device must accept any interference received,
 including that may cause undesired operation.
 Contains IC: 5131A-LE910CXNF.

NEN-EN1176-1:2017
 2024|2025|2026 1|2|3|4|5|6|7|8|9|10|11|12

1.2 Test data

Test Location	DEKRA Certification B.V., The Netherlands
Date (start)	2023-12-22
Date (finish)	2024-02-23

2 DESCRIPTION OF TEST SETUP

2.1 Sample(s) used for tests

During the tests the following sample(s) has(have) been used.

Sample	Logistics number	Model number	Serial number	Remark(s) / Changes
01	1000782/1-0	YA3400	YA3400 / 1702	---
<u>Supplementary information:</u>				

2.2 Operating mode(s) used for tests

During the tests the following operating mode(s) has(have) been used.

For UMTS:

Operation Mode	Description
OM#01	EUT ON. MS in traffic mode. UMTS Band 3. Powered by 230 Vac.
OM#02	EUT ON. MS in idle mode. UMTS Band 3. Powered by 230 Vac.

For LTE:

Operation Mode	Description
OM#01	EUT ON. MS in traffic mode. LTE Band 7. Powered by 230 Vac..
OM#02	EUT ON. MS in idle mode. LTE Band 7. Powered by 230 Vac..

2.3 Test conditions

Power supply (V):

Vnom= 230 Vac / 50 Hz.

Vmin= N/A

Vmax= N/A

Type of Power Supply: Powered by AC power.

Temperature (C):

Tn = +15 to +35.

Tmin= N/A

Tmax= N/A

TEST Setup

All radiated tests were performed in a semi-anechoic chamber. The used measurement antenna's are:

- Ultralog antenna situated at a distance of 3 m for the range between 30 MHz to 1000 MHz.
- Double ridge horn antenna is situated at a distance of 3 m for the frequency range of 1 GHz to 12.75 GHz.

The equipment under test was set up on a non-conductive platform at a height of 1,5 m above the ground plane and the situation and orientation was varied to find the maximum radiated emission. It was also rotated 360° and

the antenna height (Ultralog antenna and Double ridge horn antenna) was varied from 1 to 4 meters to find the maximum radiated emission.
 Measurements were made in both horizontal and vertical planes of polarization.

A resolution bandwidth / video bandwidth of 100 kHz / 300 kHz was used for frequencies below 1GHz and 1 MHz / 3 MHz for frequencies above 1 GHz.

Test frequencies for radiated tests:

BAND (UMTS)	EARFCN UL	Frequency (MHz)	Channel Bandwidth (MHz)
III	1113	1747.6	5

BAND (LTE)	EARFCN UL	Frequency (MHz)	Channel Bandwidth (MHz)
7	21100	2535	10

Radiated measurements setup from 30 MHz to 1 GHz:

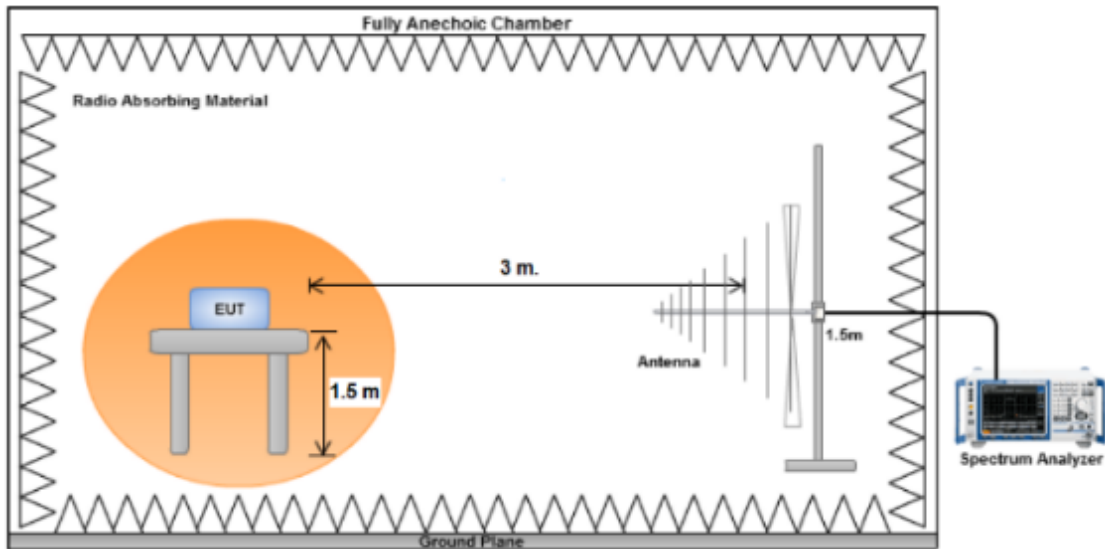

Radiated measurements setup from 1 GHz to 12.75 GHz:

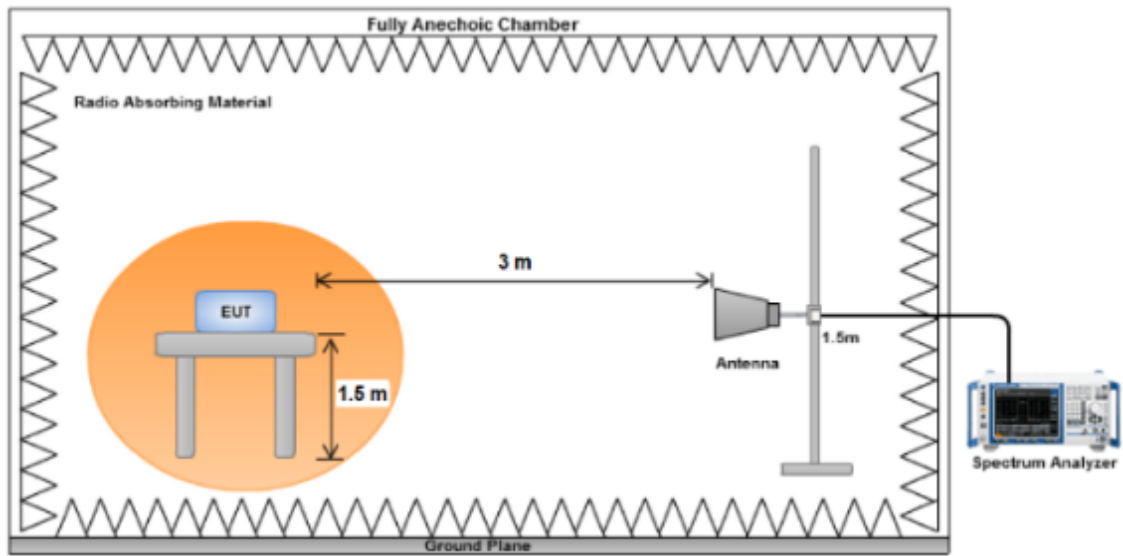

3 VERDICT SUMMARY SECTION

This chapter presents an overview of standards and results. Refer to the next chapters for details of measured test results and applied test levels.

3.1 Standards

Standard	Year	Description
ETSI EN 301 908-1 V15.2.1	2023-01	IMT cellular networks; Harmonised Standard for access to radio spectrum; Part 1: Introduction and common requirements

3.2 Overview of results – UMTS

ETSI EN 301 908			
Requirement – Test case	EN 301 908 Clause	Verdict	Remark
Transmitter conformance requirements			
Radiated emissions (UE)	4.2.2	P	See 1
Radiated emissions (BS)	4.2.3	N/A	--
Control and monitoring functions (UE)	4.2.4	N/M	See 2
Supplementary information and remarks:			
1) The module is certified. Test requested by the applicant only in Band 3. 2) The module is certified. Test not requested by the applicant.			

3.3 Overview of results – LTE

ETSI EN 301 908			
Requirement – Test case	EN 301 908 Clause	Verdict	Remark
Transmitter conformance requirements			
Radiated emissions (UE)	4.2.2	P	See 1
Radiated emissions (BS)	4.2.3	N/A	--
Control and monitoring functions (UE)	4.2.4	N/M	See 2
Supplementary information and remarks:			
1) The module is certified. Test requested by the applicant only in Band 7. 2) The module is certified. Test not requested by the applicant.			

3.4 Deviation(s) from the Standard(s) / Test Specification(s)

The following deviation(s) was / were made from the published requirements of the listed standards:
 N/A.

4 TEST RESULTS – UMTS

TEST Setup

The EUT is placed inside the chamber on a turntable. A test antenna is placed in the chamber which is connected to CMW500 on the outside of the chamber. CMW500 is used to connect and communicate with the EUT for test purposes.

4.1 Radiated Spurious Emissions (30 - 1000 MHz)	VERDICT: PASS
--	----------------------

Standard	ETSI EN 301 908-1
Supplementary information / Remark: ---	

Limits – Traffic mode

Frequency bandwidth	Measurement bandwidth	Minimum requirement
30 MHz ≤ f < 1000 MHz	100 kHz	-36 dBm
1 GHz ≤ f < 12.75 GHz	1 MHz	-30 dBm

Limits – IDLE mode

Frequency bandwidth	Measurement bandwidth	Minimum requirement
30 MHz ≤ f < 1000 MHz	100 kHz	-57 dBm
1 GHz ≤ f < 12.75 GHz	1 MHz	-47 dBm

Performed measurements

The following configuration(s) and parameter(s) was/were used for testing:

Port under test	Enclosure (with cabling)	
Test method	<input checked="" type="checkbox"/>	Semi Anechoic Chamber
	<input type="checkbox"/>	Open Area Test Site (OATS)
	<input type="checkbox"/>	In-Situ (at user/manufacturer premises)
	<input type="checkbox"/>	GTEM cell
	<input type="checkbox"/>	Other:
Test set-up	<input checked="" type="checkbox"/>	Equipment on a table of 80 cm height
	<input type="checkbox"/>	Equipment on the floor (insulated from the reference ground plane)
	<input type="checkbox"/>	Other:

OM#	[V]/[Hz] (mains)	Technology	Mode / Modulation	Band	Frequency range	Antenna Polar. / axis	Measureme nt distance	P/F	Sup. Info / Remark
01	230 / 50	UMTS	Traffic	3	30 MHz – 1 GHz	H/V	3 m.	P	---
02	230 / 50	UMTS	Idle	3	30 MHz – 1 GHz	H/V	3 m.	P	---

Supplementary information / Remark:

RESULTS (30 MHz – 1 GHz) - Traffic Mode

Mode	EARFCN UL	Results	Verdict
01	1113	No radiated spurious signals detected more than 6 dB below the limit.	P

RESULTS (30 MHz – 1 GHz) - Idle Mode

Mode	EARFCN UL	Results	Verdict
02	1113	No radiated spurious signals detected more than 6 dB below the limit.	P

RESULTS (30 MHz – 1 GHz) – UMTS Band 3 - Traffic Mode

Measurement data:

Common Information

EUT/Sample # / OM# : Luna / 01 / 01
Voltage/Frequency : 230 V / 50 Hz
Port/Terminal under test : Enclosure
Remark/Comment : UMTS Band 3 Traffic Mode

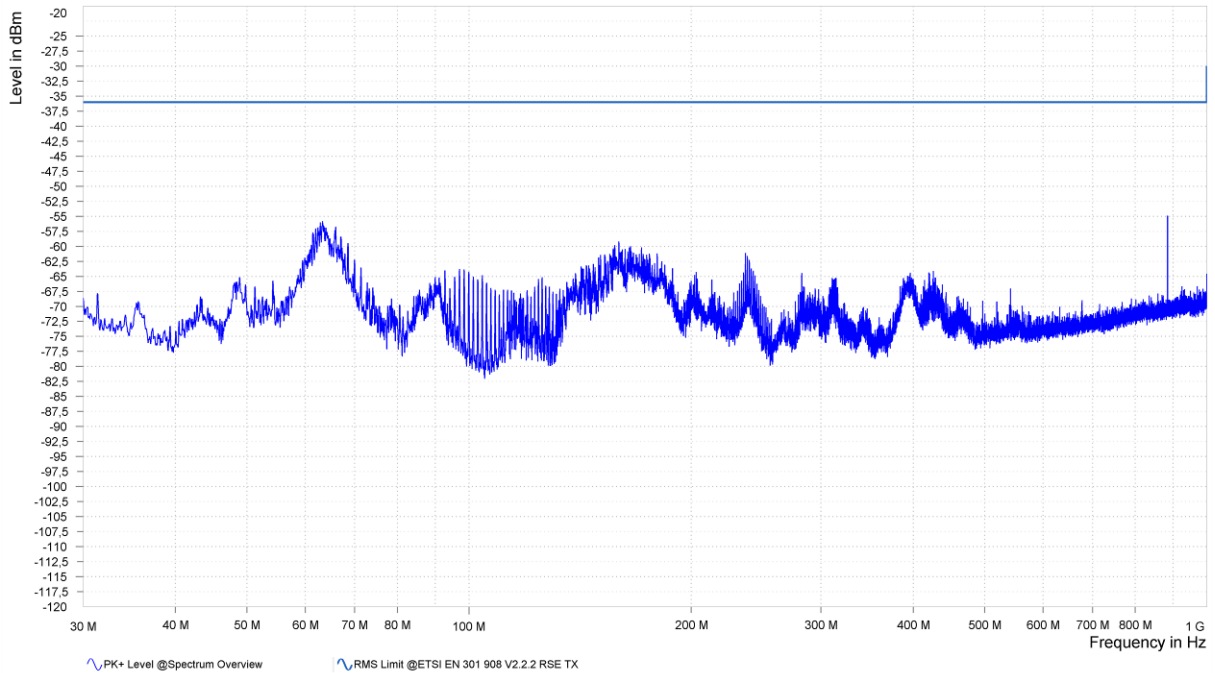

Supplementary information:

- The "Azimuth/Pol/Height" indicates the turn-table azimuth, the antenna polarization and the antenna height where the maximum emissions level was measured.
- The "Margin" is with reference to the emissions limit. A positive number indicates that the emission measurement is below the limit. A negative number indicates that the emission measurement exceeds the limit.

RESULTS (30 MHz – 1 GHz) – UMTS Band 3 - Idle Mode

Measurement data:

Common Information

EUT/Sample # / OM# : Luna / 01 / 02
 Voltage/Frequency : 230 V / 50 Hz
 Port/Terminal under test : Enclosure
 Remark/Comment : UMTS Band 3 Idle Mode

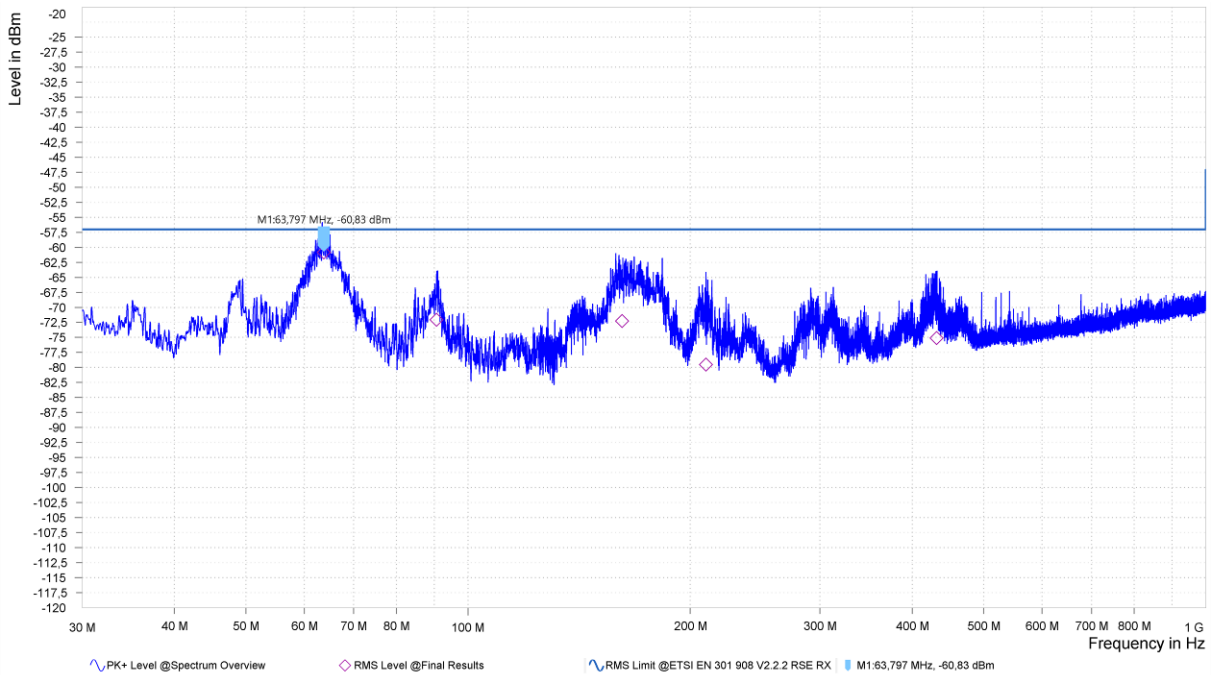

Rg	Frequency [MHz]	RMS Level [dBm]	RMS Limit [dBm]	RMS Margin [dB]	Correction [dB]	Polarization	Azimuth [deg]	Antenna Height [m]	Meas. BW [kHz]	Meas. Time [s]	Time of Meas.	Source
1	63,797	-60,83	-57,00	3,83	21,63	V	-118,9	1,48	100,000	0,030	09:32:32	Critical Points
1	90,683	-72,08	-57,00	15,08	23,63	H	57,3	2,81	100,000	0,030	09:22:22	Critical Points
1	161,764	-72,29	-57,00	15,29	22,21	V	-11,4	1,48	100,000	0,030	09:39:37	Critical Points
1	210,168	-79,53	-57,00	22,53	22,74	V	140,1	2,77	100,000	0,030	09:28:17	Critical Points
1	431,524	-75,10	-57,00	18,10	28,58	V	-75,3	1,95	100,000	0,030	09:36:00	Critical Points

Supplementary information:

- The "Azimuth/Pol/Height" indicates the turn-table azimuth, the antenna polarization and the antenna height where the maximum emissions level was measured.
 - The "Margin" is with reference to the emissions limit. A positive number indicates that the emission measurement is below the limit. A negative number indicates that the emission measurement exceeds the limit.

4.2	Radiated Spurious Emissions (1 – 12.75 GHz)	VERDICT: PASS
------------	--	----------------------

Standard	ETSI EN 301 908-1
Supplementary information / Remark:	

Limits – Traffic mode

Frequency bandwidth	Measurement bandwidth	Minimum requirement
30 MHz ≤ f < 1000 MHz	100 kHz	-36 dBm
1 GHz ≤ f < 12.75 GHz	1 MHz	-30 dBm

Limits – IDLE mode

Frequency bandwidth	Measurement bandwidth	Minimum requirement
30 MHz ≤ f < 1000 MHz	100 kHz	-57 dBm
1 GHz ≤ f < 12.75 GHz	1 MHz	-47 dBm

Performed measurements

The following configuration(s) and parameter(s) was/were used for testing:

Port under test	Enclosure (with cabling)		
Test method	X	Absorber-lined Semi Anechoic Chamber (SAC)	
		Absorber-lined Open Area Test Site (OATS)	
		In-Situ (at user/manufacturer premises)	
		Other:	
Test set-up	X	Equipment on a table of 80 cm height	
		Equipment on the floor (insulated from the reference ground plane)	
		Other:	

OM#	[V]/[Hz] (mains)	Technology	Mode / Modulation	Band	Frequency range	Antenna Polar. / axis	Measurement distance	P/F	Sup. Info / Remark
02	230/50	UMTS	Idle	3	1 – 12.75 GHz	H/V	3 m.	P	---
01	230/50	UMTS	Traffic	3	1 - 3 GHz	H/V	3 m.	P	---
01	230/50	UMTS	Traffic	3	3 - 12.75 GHz	H/V	3 m.	P	---

Supplementary information / Remark:

RESULTS (1 GHz – 3 GHz) - Traffic Mode

Mode	EARFCN UL	Results	Verdict
01	1113	No radiated spurious signals detected more than 6 dB below the limit.	P

RESULTS (3 GHz – 12.75 GHz) - Traffic Mode

Mode	EARFCN UL	Results	Verdict
01	1113	No radiated spurious signals detected more than 6 dB below the limit.	P

RESULTS (1 GHz – 12.75 GHz) - Idle Mode

Mode	EARFCN UL	Results	Verdict
02	1113	No radiated spurious signals detected more than 6 dB below the limit.	P

RESULTS (1 GHz – 3 GHz) – UMTS– Band 3 - Traffic Mode

Measurement data:

Common Information

EUT/Sample # / OM# : Luna / 01 / 01
Voltage/Frequency : 230 V / 50 Hz
Port/Terminal under test : Enclosure
Remark/Comment : UMTS Band 3 Traffic Mode

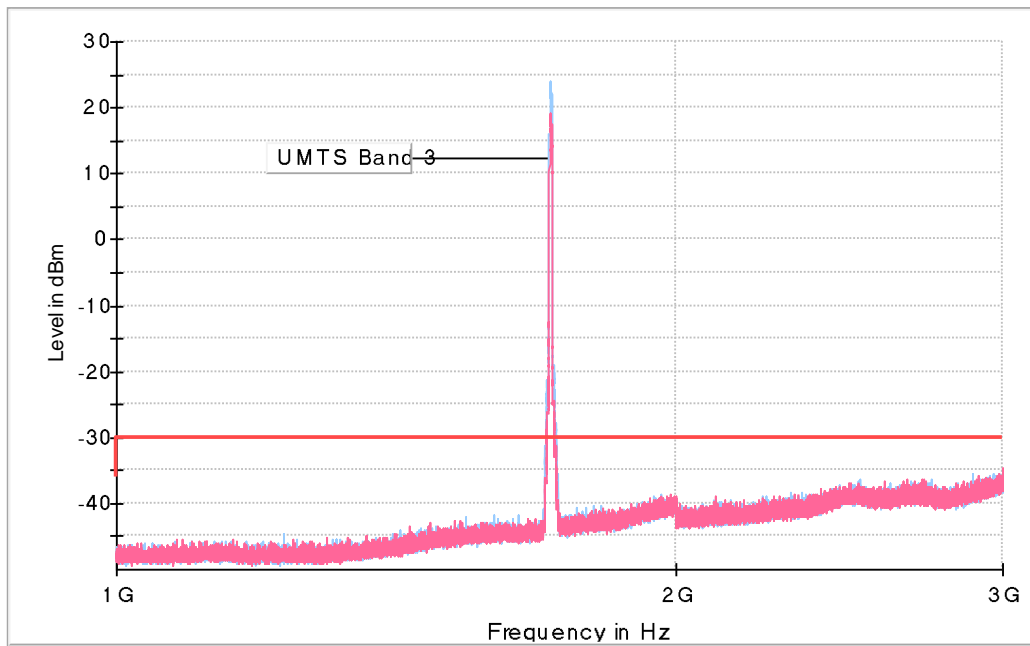

— Preview Result 1 H-PK+ — Preview Result 1 V-PK+
— UMTS LTE TX (RMS) ◆ Final_Result RMS

Supplementary information:

- The "Azimuth/Pol/Height" indicates the turn-table azimuth, the antenna polarization and the antenna height where the maximum emissions level was measured.
- The "Margin" is with reference to the emissions limit. A positive number indicates that the emission measurement is below the limit. A negative number indicates that the emission measurement exceeds the limit.
- The signal above the limit is the signal carrier.

RESULTS (3 GHz – 12.75 GHz) – UMTS– Band 3 - Traffic Mode

Measurement data:

Common Information

EUT/Sample # / OM# : Luna / 01 / 01
 Voltage/Frequency : 230 V / 50 Hz
 Port/Terminal under test : Enclosure
 Remark/Comment : UMTS Band 3 Traffic Mode

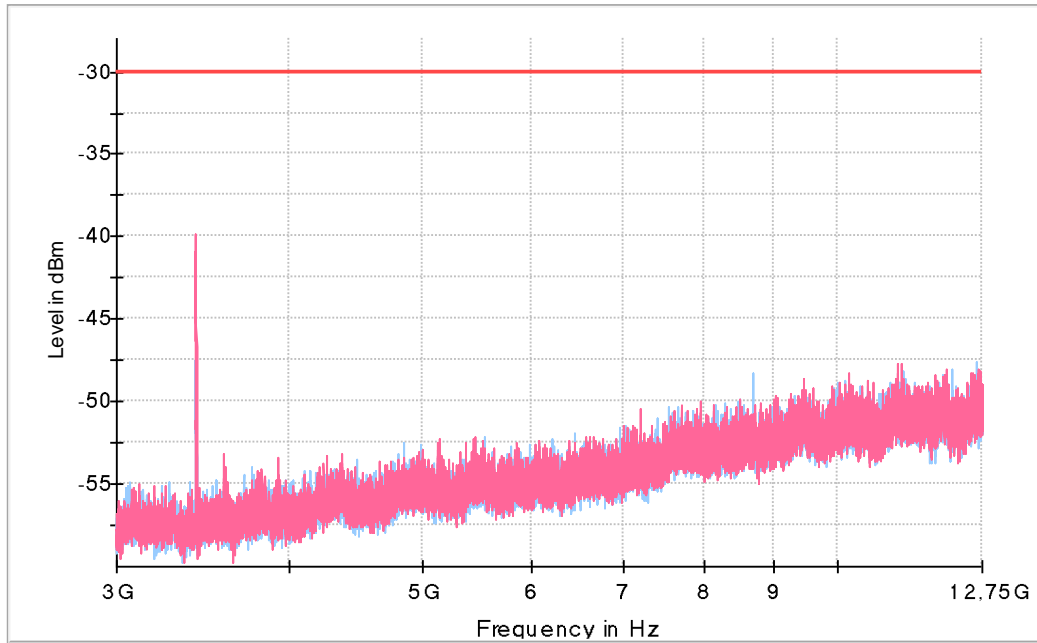

— Preview Result 1 H-PK+ — Preview Result 1 V-PK+
 — UMTS LTE TX (RMS) ◆ Final_Result RMS

Critical_Freqs

Frequency (MHz)	MaxPeak (dBm)	Limit (dBm)	Margin (dB)	Meas. Time (ms)	Bandwidth (kHz)	Height (cm)	Pol	Azimuth (deg)
3422.825000	-39.84	-30.00	9.84	---	---	180.0	V	87.0

Supplementary information:

- The "Azimuth/Pol/Height" indicates the turn-table azimuth, the antenna polarization and the antenna height where the maximum emissions level was measured.
- The "Margin" is with reference to the emissions limit. A positive number indicates that the emission measurement is below the limit. A negative number indicates that the emission measurement exceeds the limit.

RESULTS (1 GHz – 12.75 GHz) – UMTS Band 3 - Idle Mode

Measurement data:

Common Information

EUT/Sample # / OM# : Luna / 01 / 02
Voltage/Frequency : 230 V / 50 Hz
Port/Terminal under test : Enclosure
Remark/Comment : UMTS Band 3 Idle Mode

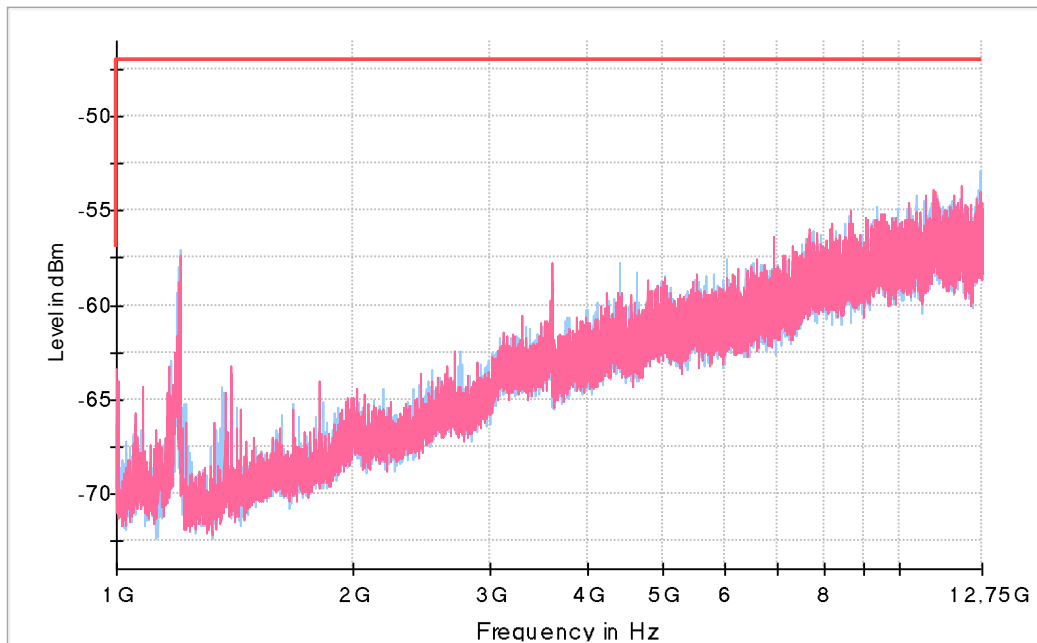

— Preview Result 1H-PK+ — Preview Result 1V-PK+
— UMTS LTE RX (RMS) ◆ Final_Result RMS

Supplementary information:

- The "Azimuth/Pol/Height" indicates the turn-table azimuth, the antenna polarization and the antenna height where the maximum emissions level was measured.
- The "Margin" is with reference to the emissions limit. A positive number indicates that the emission measurement is below the limit. A negative number indicates that the emission measurement exceeds the limit.

5 TEST RESULTS. LTE

TEST Setup

The EUT is placed inside the chamber on a turntable. A test antenna is placed in the chamber which is connected to CMW500 on the outside of the chamber. CMW500 is used to connect and communicate with the EUT for test purposes.

5.1 Radiated Spurious Emissions (30 - 1000 MHz)	VERDICT: PASS
--	----------------------

Standard	ETSI EN 301 908-1
Supplementary information / Remark:	

Limits – Traffic mode

Frequency bandwidth	Measurement bandwidth	Minimum requirement
30 MHz ≤ f < 1000 MHz	100 kHz	-36 dBm
1 GHz ≤ f < 12.75 GHz	1 MHz	-30 dBm

Limits – Idle mode

Frequency bandwidth	Measurement bandwidth	Minimum requirement
30 MHz ≤ f < 1000 MHz	100 kHz	-57 dBm
1 GHz ≤ f < 12.75 GHz	1 MHz	-47 dBm

Performed measurements

The following configuration(s) and parameter(s) was/were used for testing:

Port under test	Enclosure (with cabling)	
Test method	X	Semi Anechoic Chamber
		Open Area Test Site (OATS)
		In-Situ (at user/manufacturer premises)
		GTEM cell
		Other:
Test set-up	X	Equipment on a table of 80 cm height
		Equipment on the floor (insulated from the reference ground plane)
		Other:

OM#	[V]/[Hz] (mains)	Technology	Mode / Modulation	Band	Frequency range	Antenna Polar. / axis	Measurement distance	P/F	Sup. Info / Remark
01	230 / 50	LTE	Traffic	7	30 MHz – 1 GHz	H/V	3 m.	P	---
02	230 / 50	LTE	Idle	7	30 MHz – 1 GHz	H/V	3 m.	P	---

Supplementary information / Remark:

RESULTS (30 MHz – 1 GHz) - Traffic Mode

Mode	EARFCN UL	Results	Verdict
01	21100	No radiated spurious signals detected more than 6 dB below the limit.	P

RESULTS (30 MHz – 1 GHz) - Idle Mode

Mode	EARFCN UL	Results	Verdict
02	21100	No radiated spurious signals detected more than 6 dB below the limit.	P

RESULTS (30 MHz – 1 GHz) – LTE Band 7 - Traffic Mode

Measurement data:

Common Information

EUT/Sample # / OM# : Luna / 01 / 01
Voltage/Frequency : 230 V / 50 Hz
Port/Terminal under test : Enclosure
Remark/Comment : LTE Band 7 Traffic Mode

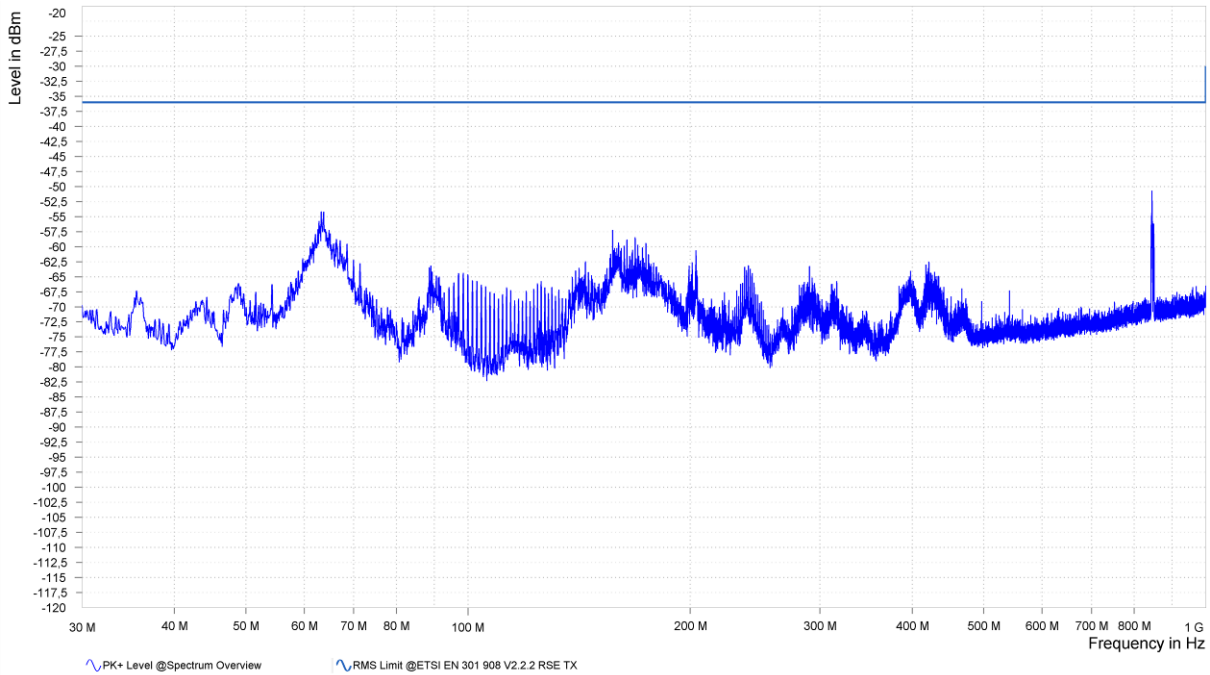

Supplementary information:

- The "Azimuth/Pol/Height" indicates the turn-table azimuth, the antenna polarization and the antenna height where the maximum emissions level was measured.
- The "Margin" is with reference to the emissions limit. A positive number indicates that the emission measurement is below the limit. A negative number indicates that the emission measurement exceeds the limit.

RESULTS (30 MHz – 1 GHz) – LTE Band 7 - Idle Mode

Measurement data:

Common Information

EUT/Sample # / OM# : Luna / 01 / 02
 Voltage/Frequency : 230 V / 50 Hz
 Port/Terminal under test : Enclosure
 Remark/Comment : LTE Band 7 Idle Mode

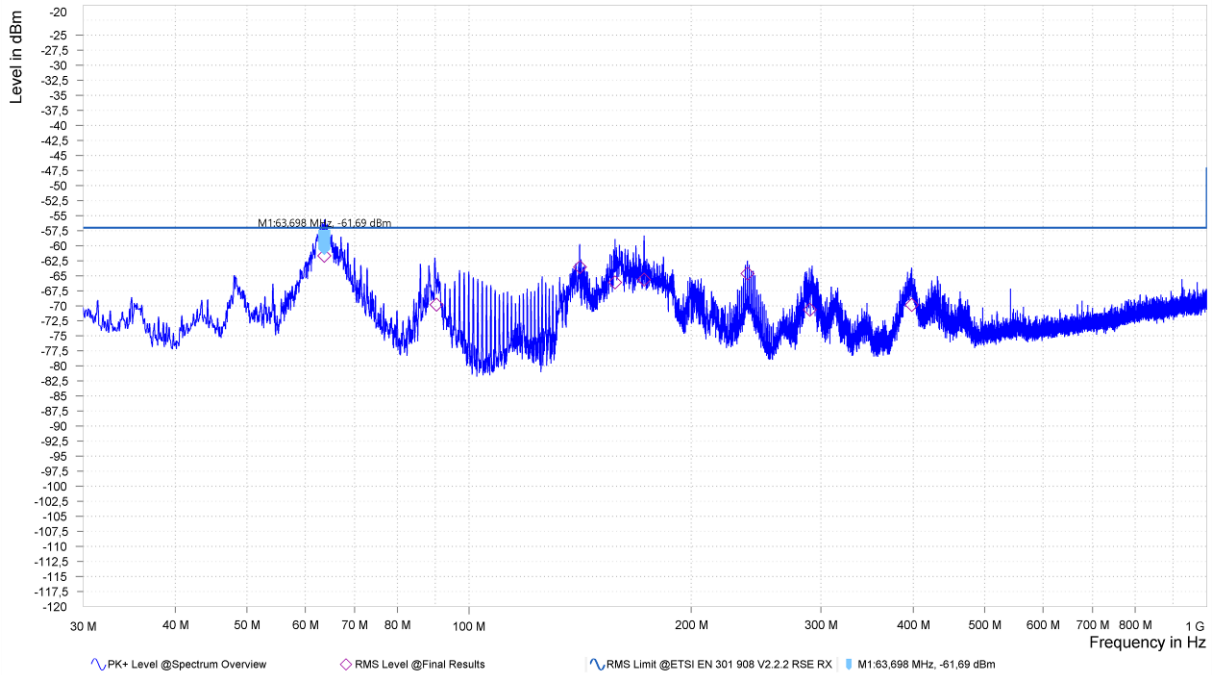

Rg	Frequency [MHz]	RMS Level [dBm]	RMS Limit [dBm]	RMS Margin [dB]	Correction [dB]	Polarization	Azimuth [deg]	Antenna Height [m]	Meas. BW [kHz]	Meas. Time [s]	Time of Meas.	Source
1	63,698	-61,69	-57,00	4,69	21,62	V	-131,5	1,44	100,000	0,030	10:35:38	Critical Points
1	90,368	-69,81	-57,00	12,81	23,61	H	61,7	1,45	100,000	0,030	10:28:28	Critical Points
1	141,409	-63,57	-57,00	6,57	22,51	H	-120,9	1,45	100,000	0,030	10:11:37	Critical Points
1	157,739	-66,09	-57,00	9,09	22,17	H	-94	0,98	100,000	0,030	10:21:24	Critical Points
1	172,797	-65,65	-57,00	8,65	22,31	H	-141,2	2,79	100,000	0,030	10:14:41	Critical Points
1	238,573	-64,64	-57,00	7,64	23,55	V	152,2	1,44	100,000	0,030	10:39:34	Critical Points
1	289,810	-70,65	-57,00	13,65	25,00	H	-18,3	1,47	100,000	0,030	10:24:52	Critical Points
1	398,295	-69,84	-57,00	12,84	27,82	H	-80,4	2,35	100,000	0,030	10:18:03	Critical Points

Supplementary information:

- The "Azimuth/Pol/Height" indicates the turn-table azimuth, the antenna polarization and the antenna height where the maximum emissions level was measured.
- The "Margin" is with reference to the emissions limit. A positive number indicates that the emission measurement is below the limit. A negative number indicates that the emission measurement exceeds the limit.

5.2	Radiated Spurious Emissions (1 – 12.75 GHz)	VERDICT: PASS
------------	--	----------------------

Standard	ETSI EN 301 908-1
Supplementary information / Remark: ---	

Limits – Traffic mode

Frequency bandwidth	Measurement bandwidth	Minimum requirement
30 MHz ≤ f < 1000 MHz	100 kHz	-36 dBm
1 GHz ≤ f < 12.75 GHz	1 MHz	-30 dBm

Limits – IDLE mode

Frequency bandwidth	Measurement bandwidth	Minimum requirement
30 MHz ≤ f < 1000 MHz	100 kHz	-57 dBm
1 GHz ≤ f < 12.75 GHz	1 MHz	-47 dBm

Performed measurements

The following configuration(s) and parameter(s) was/were used for testing:

Port under test	Enclosure (with cabling)		
Test method	X	Absorber-lined Semi Anechoic Chamber (SAC)	
		Absorber-lined Open Area Test Site (OATS)	
		In-Situ (at user/manufacturer premises)	
		Other:	
Test set-up	X	Equipment on a table of 80 cm height	
		Equipment on the floor (insulated from the reference ground plane)	
		Other:	

OM#	[V]/[Hz] (mains)	Technology	Mode / Modulation	Band	Frequency range	Antenna Polar. / axis	Measurement distance	P/F	Sup. Info / Remark
02	230/50	LTE	Idle	7	1 – 12.75 GHz	H/V	3 m.	P	---
01	230/50	LTE	Traffic	7	1 - 3 GHz	H/V	3 m.	P	---
01	230/50	LTE	Traffic	7	3 - 12.75 GHz	H/V	3 m.	P	---

Supplementary information / Remark:

RESULTS (1 GHz – 3 GHz) - Traffic Mode

Mode	EARFCN UL	Results	Verdict
01	21100	No radiated spurious signals detected more than 6 dB below the limit.	P

RESULTS (3 GHz – 12.75 GHz) - Traffic Mode

Mode	EARFCN UL	Results	Verdict
01	21100	No radiated spurious signals detected more than 6 dB below the limit.	P

RESULTS (1 GHz – 12.75 GHz) - Idle Mode

Mode	EARFCN UL	Results	Verdict
02	1113	No radiated spurious signals detected more than 6 dB below the limit.	P

RESULTS (1 GHz – 3 GHz) – LTE– Band 7 - Traffic Mode

Measurement data:

Common Information

EUT/Sample # / OM# : Luna / 01 / 01
 Voltage/Frequency : 230 V / 50 Hz
 Port/Terminal under test : Enclosure
 Remark/Comment : LTE Band 7 Traffic Mode

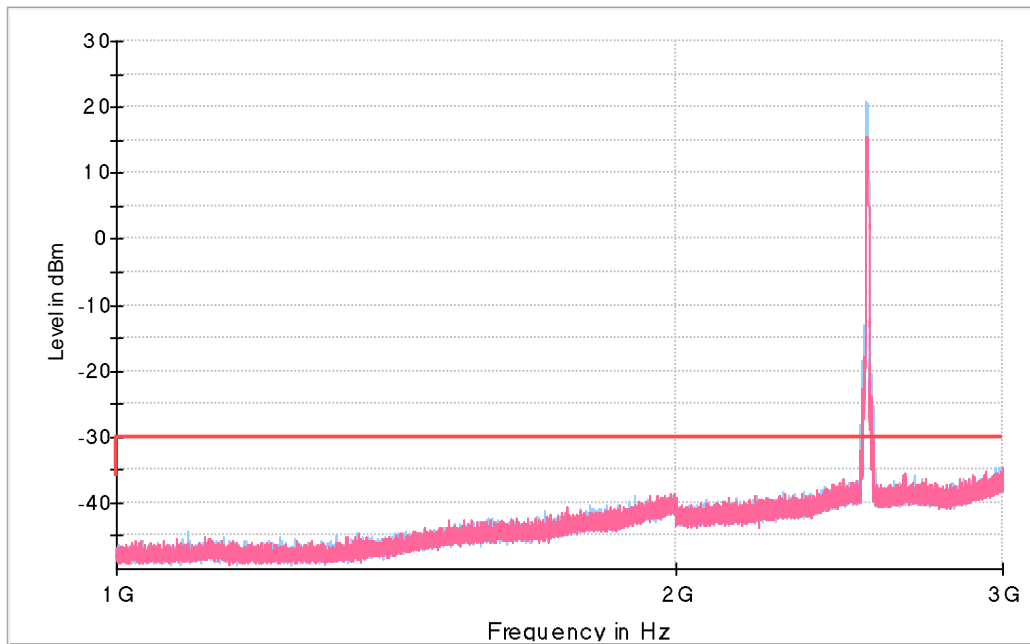

— Preview Result 1 H-PK+ — Preview Result 1 V-PK+
— UMTS LTE TX (RMS) ◆ Final_Result RMS

Supplementary information:

- The "Azimuth/Pol/Height" indicates the turn-table azimuth, the antenna polarization and the antenna height where the maximum emissions level was measured.
- The "Margin" is with reference to the emissions limit. A positive number indicates that the emission measurement is below the limit. A negative number indicates that the emission measurement exceeds the limit.
- The signal above the limit is the signal carrier.

RESULTS (3 GHz – 12.75 GHz) – LTE– Band 7 - Traffic Mode

Measurement data:

Common Information

EUT/Sample # / OM# : Luna / 01 / 01
 Voltage/Frequency : 230 V / 50 Hz
 Port/Terminal under test : Enclosure
 Remark/Comment : LTE Band 7 Traffic Mode

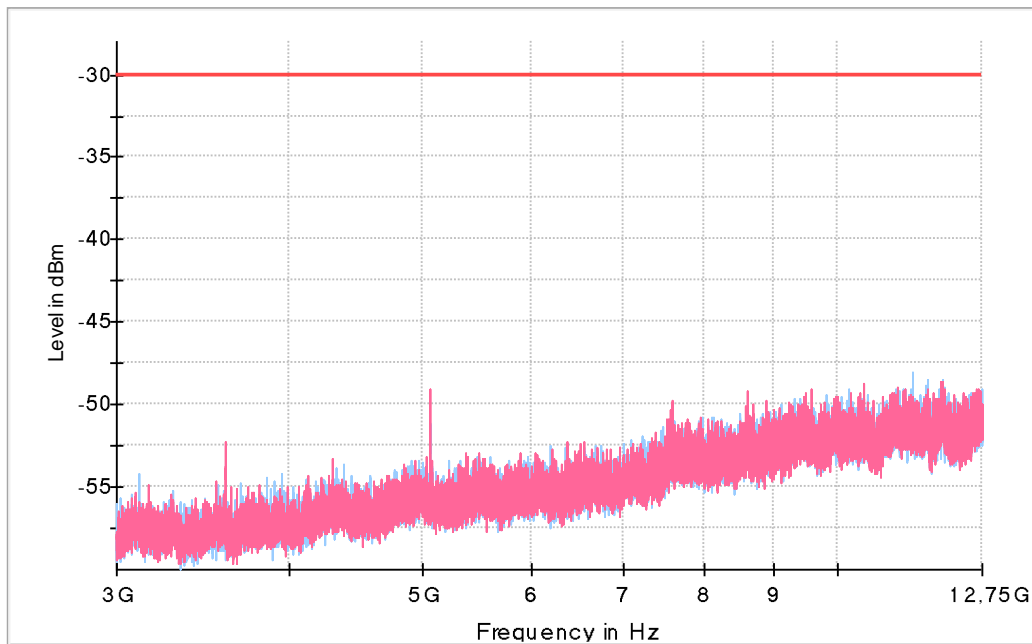

— Preview Result 1 H-PK+ — Preview Result 1 V-PK+
— UMTS LTE TX (RMS) ◆ Final_Result RMS

Supplementary information:

- The "Azimuth/Pol/Height" indicates the turn-table azimuth, the antenna polarization and the antenna height where the maximum emissions level was measured.
- The "Margin" is with reference to the emissions limit. A positive number indicates that the emission measurement is below the limit. A negative number indicates that the emission measurement exceeds the limit.

RESULTS (1 GHz – 12.75 GHz) – LTE Band 7 - Idle Mode

Measurement data:

Common Information

EUT/Sample # / OM# : Luna / 01 / 02
 Voltage/Frequency : 230 V / 50 Hz
 Port/Terminal under test : Enclosure
 Remark/Comment : LTE Band 7 Idle Mode

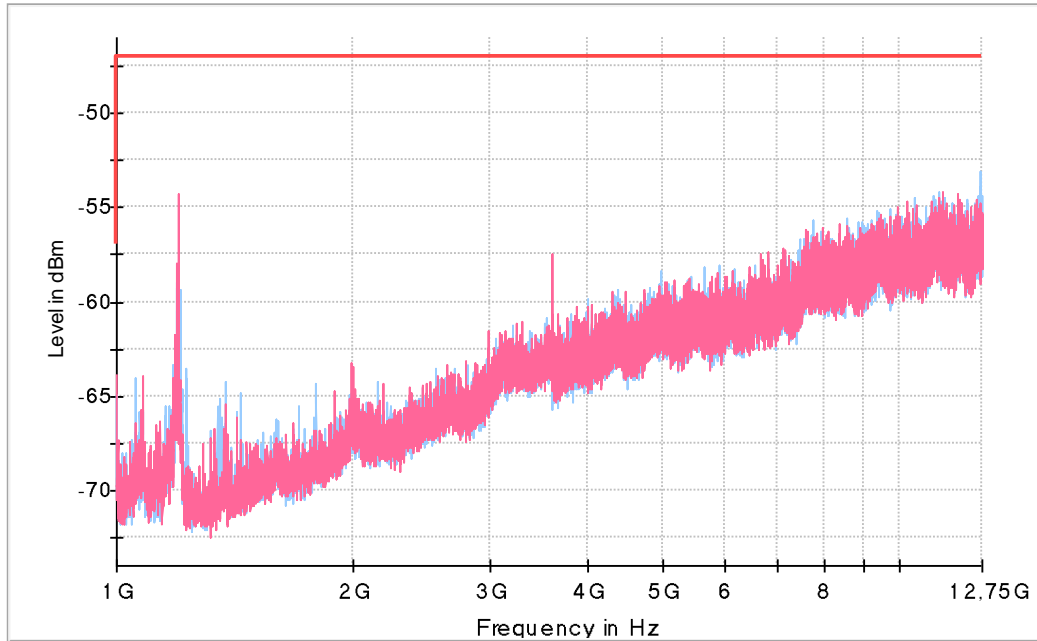

— Preview Result 1H-PK+ — Preview Result 1V-PK+
 — UMTS LTE RX (RMS) ◆ Final_Result RMS

Critical_Freqs

Frequency (MHz)	MaxPeak (dBm)	Limit (dBm)	Margin (dB)	Meas. Time (ms)	Bandwidth (kHz)	Height (cm)	Pol	Azimuth (deg)
1199.750000	-54.22	-47.00	7.22	---	---	180.0	V	27.0

Supplementary information:

- The "Azimuth/Pol/Height" indicates the turn-table azimuth, the antenna polarization and the antenna height where the maximum emissions level was measured.
 - The "Margin" is with reference to the emissions limit. A positive number indicates that the emission measurement is below the limit. A negative number indicates that the emission measurement exceeds the limit.

6 DESCRIPTION OF MODIFICATIONS

1. R296 Removed (decouple SYS_RESETEn From PHY RESETn)
2. Place a Ground connection on PHY_RESETEn to put the line in reset.

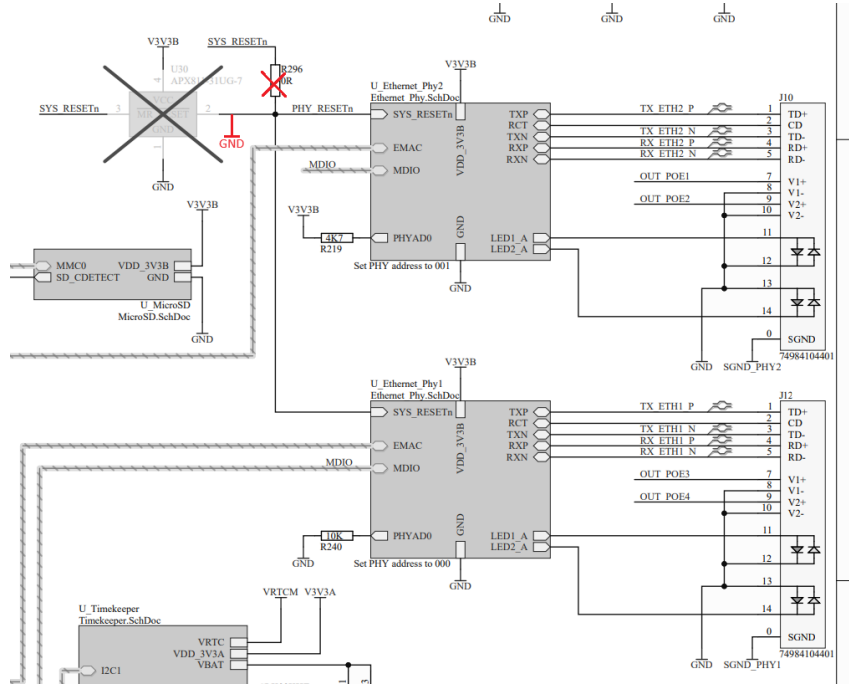

6.1 Photos

Identification of the modifications:

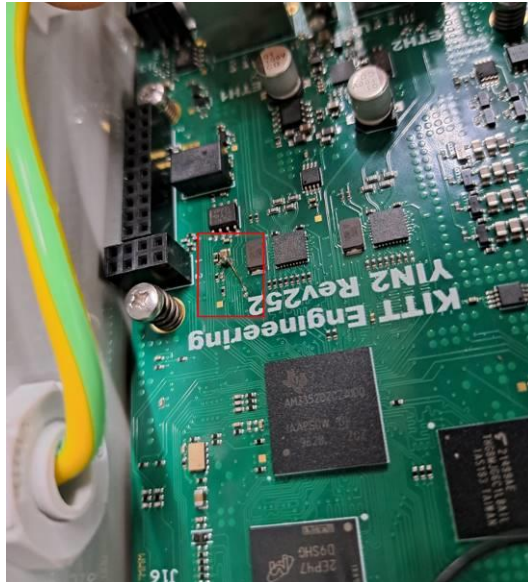

ANNEX 1: USED EQUIPMENT

#	Manufacturer	Description	DEKRA ID
1	Rohde & Schwarz	ESU26 EMI Test Receiver	126351
2	Bonn Elektronik	Pre-Amp	134808
4	Rohde & Schwarz	Biconical / Logper Antenna	132292
5	Rhode & Schwarz	Horn Antenna	134927
6	Huber & Suhner	RF Blue Cable (10m)	134187
7	Huber & Suhner	RF Blue Cable (1m)	134185
8	Huber & Suhner	RF Blue Cable (5m)	132533
9	Wainwright instruments	High Pass Filter	132561-D
10	Comtest	Anechoic Chamber 5m	129683
11	ETS-Lindgren	Anechoic Chamber 5m	135615
12	Rohde-Schwarz	EMC32 V10.60.20	500000
13	Rohde-Schwarz	CMW500	140106
14	Rohde & Schwarz	ESW44	135750
15	Rohde-Schwarz	Elektra V5.01	500160

ANNEX 2: PHOTOGRAPHS

Identification of the equipment under test:



Test Photo(s):

Test set-up 30 MHz - 1 GHz

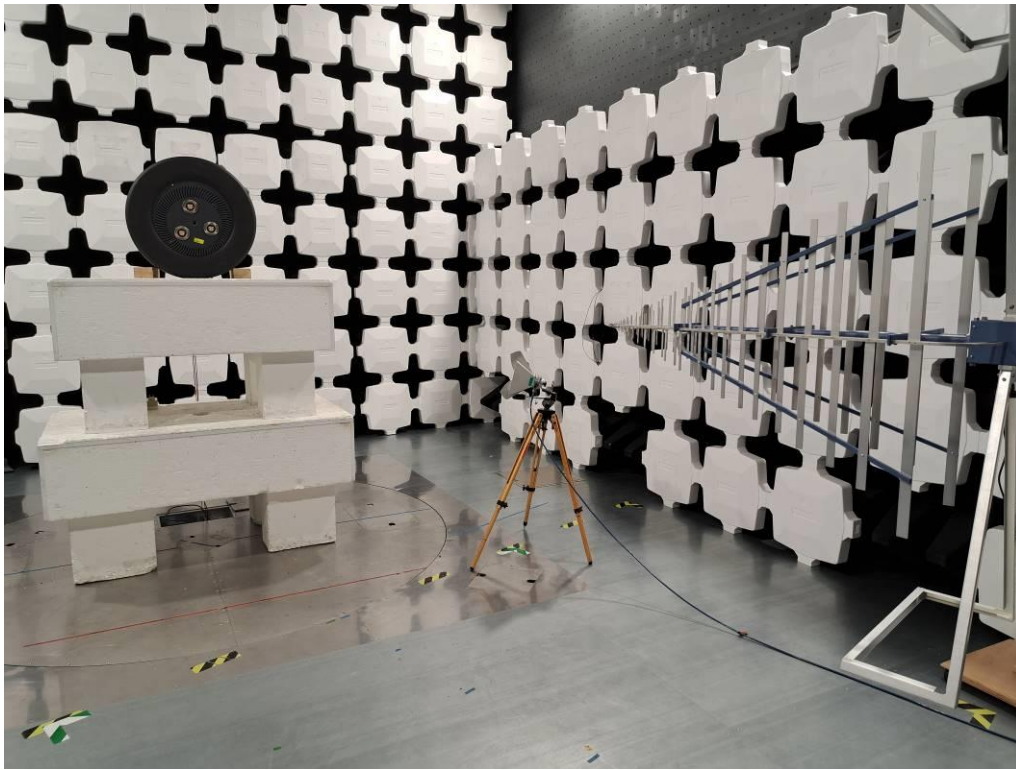

Test set-up 1 – 12.75 GHz



END OF REPORT